



## MOBILE ELEVATING WORK PLATAFORM SQ140X PRO



## Contents

1 Instructions for use .....	1
1.1 Overview .....	1
1.2 Operation rules.....	1
1.3 Application environments .....	1
1.4 Storage conditions.....	2
1.5 Obligations and responsibilities of the user.....	2
1.6 Installation of attachments or modification of the machine.....	2
2. Introduction.....	4
2.1 Overview .....	4
2.2 Functions.....	5
2.3 Key parts.....	7
2.4 Display and control.....	8
2.5 Labels and signs .....	10
2.6 Main performance parameters .....	11
3 Safety rules .....	16
3.1 Overview .....	16
3.2 Instructions on signs.....	16
3.4 Risk of electrical shock .....	18
3.5 Danger of rollover .....	19
3.6 Hazards in the work environment.....	21
3.7 Danger of unsafe operation.....	22
3.8 Danger of falling.....	23
3.9 Danger of collision .....	25
3.10 Danger of jamming .....	26
3.11 Danger of explosion/fire.....	26
3.12 Danger of machine damage.....	26
3.13 Danger of physical injury .....	27
3.14 Battery hazards .....	27

3.15 Hydraulic system hazards.....	28
3.16 Welding and grinding safety.....	28
3.17 Lock after use.....	28
4. Lifting, fastening and towing.....	30
4.1 Lifting.....	30
4.2 Fastening and fixing.....	31
4.3 Tow.....	31
5 Checks before operation.....	32
5.1 Check the machine.....	32
5.2 Checks before operation.....	33
6. Functional test before operation.....	35
6.1 Test the ground controller.....	35
6.2 Test the platform control handle.....	36
6.3 Test the safety function.....	37
7 Operation instructions.....	41
7.1 Emergency measures.....	41
7.2 Operate on the ground.....	41
7.3 Operate on the platform.....	42
7.4 Extend and retract the platform.....	43
7.5 Maintenance arm.....	44
7.6 Battery and charger.....	45
8. Maintenance.....	46
8.1 Instructions on maintenance.....	46
8.2 Table of maintenance schedules.....	46
8.3 Maintenance report.....	47

# 1 Instructions for use

## 1.1 Overview

The all-electric scissor lift described in this manual is only suitable for lifting or lowering personnel or the relevant operating tools and materials to the designated height.

Users must operate and maintain the all-electric scissor lift according to this manual. Do not use the all-electric scissor lifts for purposes not mentioned in this manual as it may cause personal injury or even death, or cause damage to the lift and other property.

## 1.2 Operation rules

Before any operations,

\*Ensure that you have understood and practiced the rules for safe operation of the machine in this operation manual.

- Avoid possible hazards.
- Always perform a pre-operation check.
- Always perform a functional test before use.
- Check the workplace.
- Use the machine only according to its design intent.

\* Read, understand and follow the manufacturer's instructions and safety rules, operation manuals and machine labels.

\* Read, understand and abide by the user's safety rules and workplace regulations.

\* Read, understand and comply with all applicable government regulations.

\* Ensure that you have been properly trained to operate the machine safely.

## 1.3 Application environments

\*The ground should be solid and flat and free from any subsidence during operation.

\*Ambient temperature should be - 20°C to 40°C.

\*Relative humidity should not be greater than 90% (at 20°C).

\*Altitude should not be greater than 1,000m.

\*The wind speed should not be greater than 12.5m/s.

\*The power supply voltage fluctuation should be within  $\pm 10\%$ .

#### 1.4 Storage conditions

\*The all-electric scissor lift should be stored in an environment free from rain, sunlight and corrosive gases.

\*During storage, the all-electric scissor lift should be retracted to the bottom and then placed on solid ground to make it horizontal in all dimensions. If pneumatic tires are used, the wheels should be lifted from the ground.

\*Check, repair and maintain the platform according to the instruction manual before use after it has been idle for a long time (more than one month).

#### 1.5 Obligations and responsibilities of the user

In this manual, the User refers to any natural or legal person who directly uses or appoints another person to use the all-electric scissor lift. In special cases such as leasing or renting, the User refers to the party who assumes the specified operational obligations according to the terms of the contract between the machine owner and the user.

The User must ensure that the all-electric scissor lift is used only for the specified purpose and that any danger that may risk the life and health of the user or third party is eliminated in a timely manner. In addition, the User must strictly observe accident prevention regulations, other technical safety regulations, and guidelines for the operation, maintenance and repair of the all-electric scissor lift. The User must ensure that all operators read and fully understand the content in this manual.

Failure to comply with this manual will automatically void our warranty. We are also not responsible for any damage or losses caused by the user and/or third parties who perform unauthorized operations on the all-electric scissor lift without our permission.

#### 1.6 Installation of attachments or modification of the machine

No private modification of the all-electric scissor lift is allowed without the authorization of the manufacturer.

If it is necessary to install or add additional devices that affect or add new functions to the machine, prior

written consent must be obtained from the manufacturer. Depending on the actual situation, the approval and consent of the local authorities may also be required.

Any modification or refit of the vehicle that affects its performance, such as the rated capacity, stability, or safety, is not permitted without prior written approval of the original manufacturer, its authorized representative, or its successor. The aforementioned modifications include modifications or refit of the platform, scissors, frame, side door, braking, steering, visibility, and the addition of removable attachments. When the manufacturer or its successor approves any modifications to the all-electric scissor lift, its nameplate, signs/labels and user's manual should also be modified accordingly.

Only if the original manufacturer is no longer in this industry and no other enterprise has taken over the business, is the user allowed to make modifications to the machine, but the user should comply with the following rules:

\*Entrust engineers specialized in industrial vehicle safety for the design, test and execution of the vehicle modification or refit.

\*Keep a permanent record of the design, test and execution of the vehicle modification or refit.

\*Modify its nameplate, signs/labels and user's manual accordingly.

\*Fix a permanent and visible sign on the all-electric scissor lift, which states that it has been modified or refitted and indicates the date of modification or refit and the name & address of the organization that completed the work.

## 2. Introduction

### 2.1 Overview

This manual introduces the mobile elevating work platform and the user can determine the lifting height and other information from the product model.

Model	Meaning
140	Lifting height x 100mm
X	Scissor type

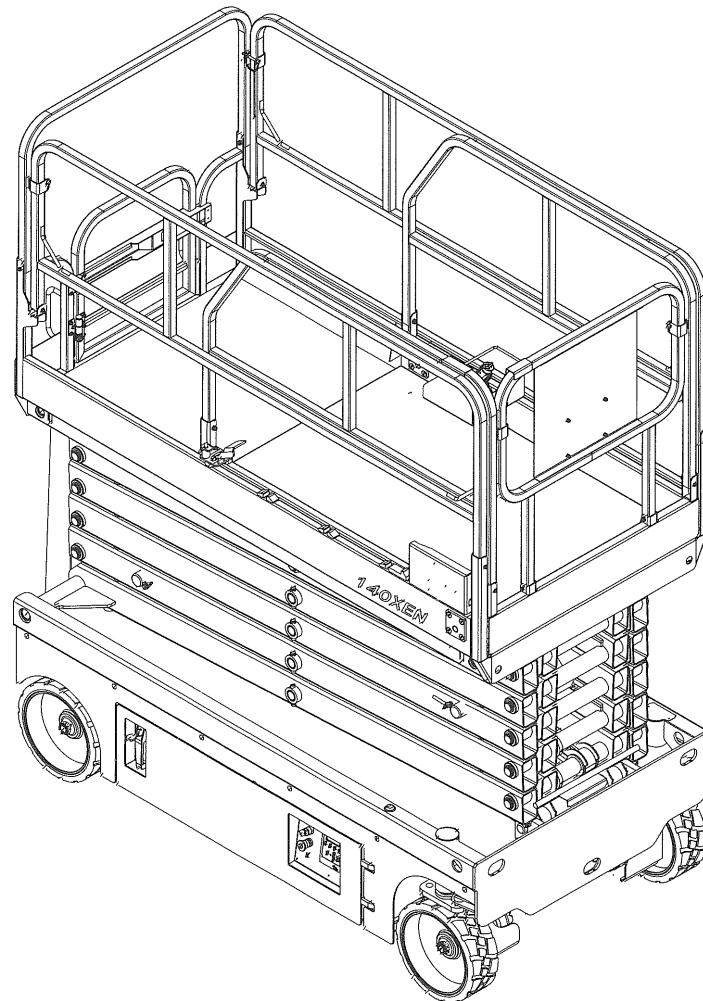

### 2.2 Functions

#### Vehicle structure

\*A serialization packaging design is adopted for the frame which features good water and dust resistance, with tie-down points for transportation, so it is easy to load, unload and transport. The left- and right-side doors can be opened by rotation for easy installation of the components of the hydraulic system and electrical system and after-sale maintenance.

A double scissor structure is adopted and features high stability, minimal swaying, safe and stable lifting/lowering action. Rubber gaskets are mounted between the square tubes, which acts buffers during lowering and prevent hands from being jammed to protect personnel. The maintenance arm is provided to facilitate maintenance in case of any faults.

\*A folding design is adopted for the work platform and the height of the machine is reduced after the platform is folded for ease of maneuvering. With a one-way extension function, the maximum extension length of the platform is 0.9m to assist reaching the work area and increasing the operation scope. The platform base is made of tread plates which are anti-skid and durable.

#### Main configuration

\*The components of the hydraulic system have stable and reliable performance, and are sourced from high-end brands to ensure consistent and smooth working performance. A emergency lowering device is provided, so that in the event of any faults in the electrical system, manual lowering can be performed, a braking release device is also provided, so when the machine is stuck due to a fault, the operator can release the brake manually to drive the machine.

\*The electrical system adopts the most common control system in used this industry, and the ground control panel and the platform control handle are equipped with separate emergency stop switches, thus, in case of an emergency, all actions can be immediately stopped by pressing the emergency switch button, to ensure the safety of operators. The control handle integrates the traveling, lifting and steering control functions, and can be operated by one hand. Proportional control is adopted to reduce the impact of movement and ensure a steady and smooth operation. The ground control panel is equipped with a timer to display the running time of the machine. The chassis is equipped with a display screen to display the electrical fault codes for the ease of fault diagnosis. The machine is equipped with a charger to facilitate charging the battery and an all-action warning system which will give a sound-light alarm from the buzzer

and strobe light when any action is performed.

\*Different types of batteries can be specified for the machine, including a lead-acid battery, traction battery and lithium-ion battery, the traction battery has a large capacity and long service life, while the charging time of the lithium-ion battery is shorter, with a high efficiency.

### Safety devices

\*2-m stop device: When the platform is lowered to a height of 2 meters, the lowering action will be paused. If the operator wants to restart the lowering process, he/she should re-press the lowering button and the platform will be lowered again after a 3s delay, to avoid any danger to people on the ground.

\* Anti-rollover protection device: It opens automatically when the platform is lifted to ensure that the machine will not roll over when the machine is driven over a pothole.

\*Hydraulic cylinder anti-burst device: It is used to prevent the hydraulic pipe from bursting and automatically lowers the platform to ensure the personnel safety.

\*Tilt alarm device: When the machine tilts beyond the setting range, the buzzer will emit an urgent alarm sound, and the platform cannot be lifted.

\*Overload alarm device: When the values detected by the height sensor and pressure sensor exceed the curve setting values, the platform cannot be lifted, and the buzzer will sound an alarm.

\*Charge protection system: When charging the battery, the system will automatically cut off the whole circuit to ensure electrical safety.

### 2.3

1. Access door
2. Brake pedal
3. Control handle
4. File case
5. Extensible platform
6. Safety belt anchorage
7. Fixed platform
8. Scissor arms
9. Chassis
10. Steering assembly
11. Tires (Solid tire)
12. Battery
13. Power-off switch
14. Charger
15. Anti-rollover device
16. Emergency lowering handle
17. Step board
18. Brake release valve
19. Maintenance arm
20. Warning light
21. Control module
22. Chassis control panel
23. Limit switch
24. Level sensor
25. Inching switch

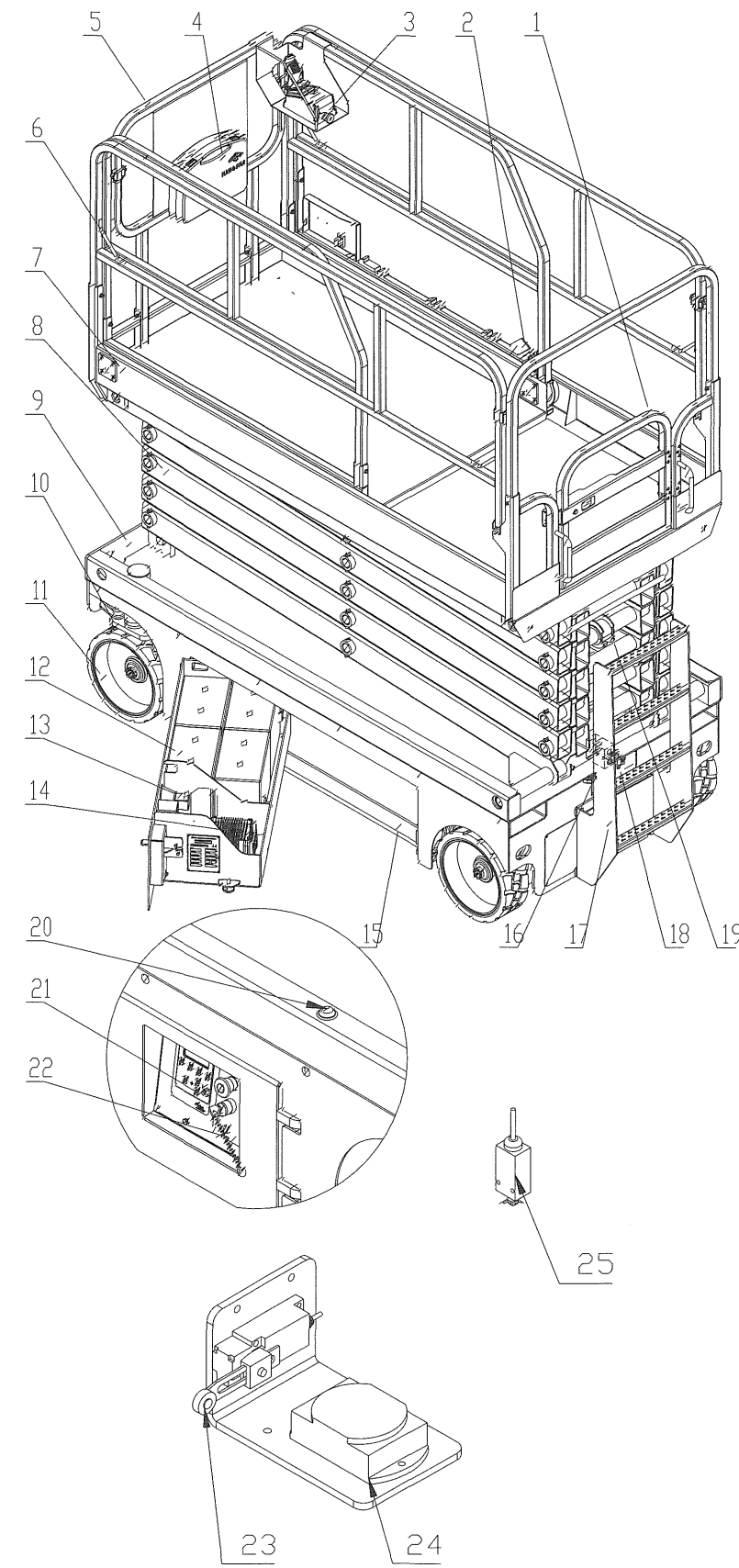

## 2.4 Display and control

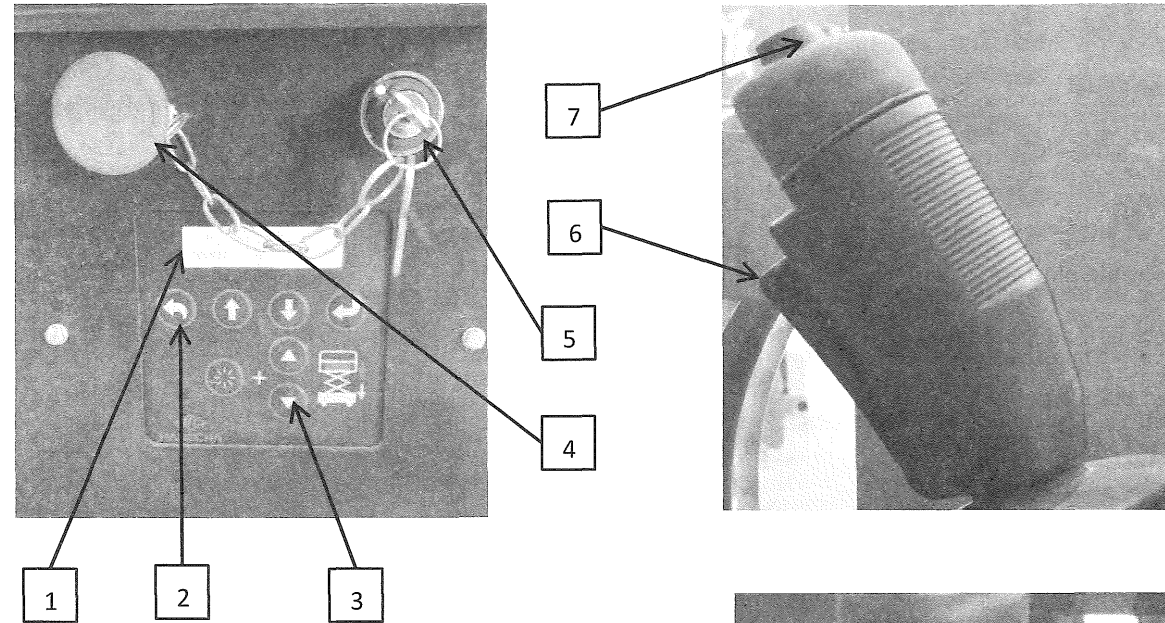

1. ECU Display screen: It is used to display machine modes or fault codes.

2. Parameter setting: It is used to set/change the system parameters.

3. Ground lifting/lowering control: It is used to control the lifting and lowering action of the platform on the ground.

4. Emergency stop switch: It is used to stop all functional actions.

5. Key switch: It is used to switch between the ground and platform control.

6. Enable button: It is used to enable the driving/lifting function.

7. Steering button: It is used to control the machine to turn left or right

8. Control handle: It is used to control the lifting, lowering, forward and backward action of the machine.

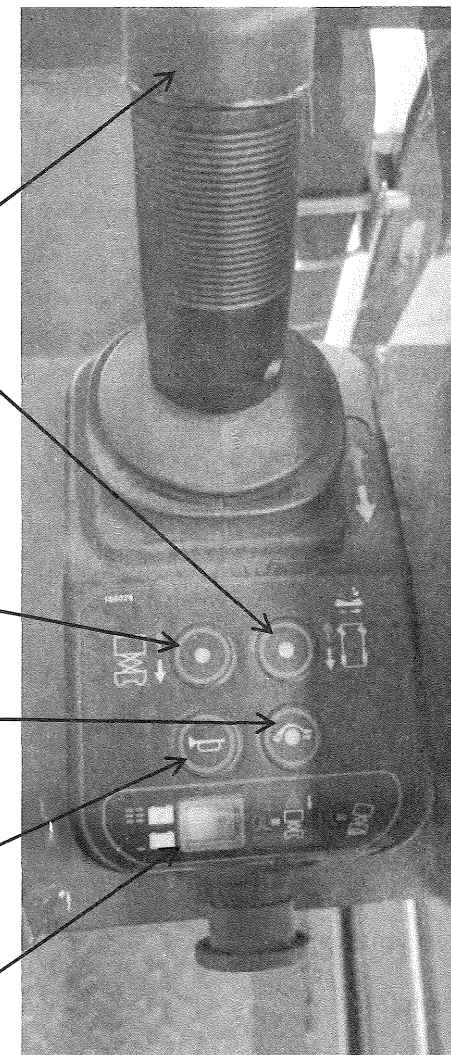
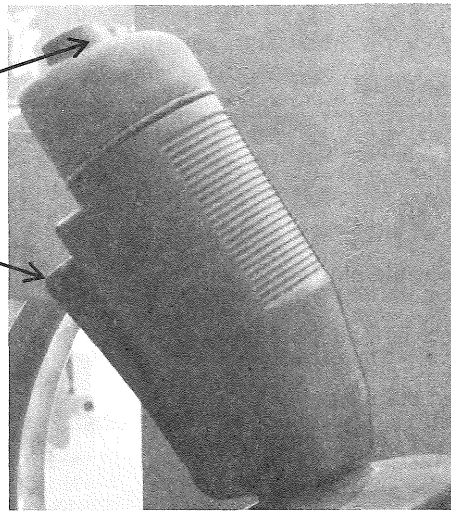

9. Driving button: The driving function is activated when the indicator light turns on.

10. Lifting button: The lifting function is activated when the indicator light turns on.

11. Speed button: The low-speed mode is activated when the indicator light turns on.

12. Horn button: It is used to sound the horn.

13. PCU Display screen: It is used to display the current battery level or fault codes.

## 2.5 Labels and signs

The labels and warning signs, such as the product nameplate, load curve sign and warning labels, must be clear and visible. If not, they should be replaced. Please become familiar with the labels and signs before operating the machine.

1. Safety belt anchorage label
2. Rated load capacity label
3. Safety belt hook label
4. Manufacturer label
5. Vehicle model label
6. Mind your head label
7. Danger of trapping label
8. Maintenance instruction label
9. Tire load capacity label
10. Tire replacement warning label
11. Battery safety warning label
12. Battery replacement warning label
13. Power-off instruction label
14. Foot trap warning label
15. Warning line label
16. Tie-down point for lifting label
17. Emergency lowering instruction label
18. Brake release instruction label
19. Platform safe load label
20. Waterproof label
21. Pre-operation caution label
22. Manufacturer label
23. IPAF label
24. CE label
25. Product nameplate

## 2.6 Main performance parameters

The technical data given below lists the parameters of machine in standard configuration. Our company reserves the right to make changes and additions to the technical data.

Parameter		Unit	80X	100X
Dimensions	Length	m	2.48	2.48
	Width	m	0.81	0.81
	Height (folded guardrail)	m	1.77	1.91
	Height (unfolded guardrail)	m	2.21	2.35
Ground clearance		mm	100	100
Ground clearance (with enabled anti-rollover device)		mm	20	20
Total weight		kg	2000	2170
Working size	Max. platform height	m	6.00	8.00
	Max. working height	m	8.00	10.00
	Max. horizontal length	m	0.90	0.90
Safe working load		kg	380	230
Safe load for extended platform		kg	113	113
Max. working staff		Number of people	Indoors only - 2	Indoors only - 2
Wheelbase		m	1.86	1.86
Wheel track		m	0.71	0.71
Turning radius	Inner wheel	m	0	0
	Outer wheel	m	2.1	2.1
Max allowable lateral force		N	400N	400N
Control voltage (DC)		V	24	24
Platform size	Length	m	2.27	2.27
	Width	m	0.76	0.76
Tire size	Diameter	mm	381	381
	Width	mm	127	127
Hydraulic system pressure		MPa	24	24
System voltage (DC)		V	24	24
Vehicle speed	Retracted state	km/h	3.5	3.5
	Extended state	km/h	0.8	0.8
Gradeability		%	25	25
Max allowable wind speed		m/s	0	0
Max allowable tilt angle	Front/Rear	°	3	3
	Left/Right	°	1.5	1.5
Normal working noise		dB	≤80	≤80

Parameter		Unit	80X	100X
Dimensions	Length	m	2.48	2.48
	Width	m	1.15	1.15
	Height (folded guardrail)	m	1.66	1.79
	Height (unfolded guardrail)	m	2.22	2.36
Ground clearance		mm	100	100
Ground clearance (with enabled anti-rollover device)		mm	20	20
Total weight		kg	2130	2310
Working size	Max. platform height	m	6.00	8.00
	Max. working height	m	8.00	10.00
	Max. horizontal length	m	0.9	0.9
Safe working load		kg	450	450
Safe load far extended platform		kg	113	113
Max. working staff		Number of people	2	2
Wheelbase		m	1.86	1.86
Wheel track		m	1.02	1.02
Turning radius	Inner wheel	m	0	0
	Outer wheel	m	2.2	2.2
Max allowable lateral force		N	400	400
Control voltage (DC)		V	24	24
Platform size	Length	m	2.27	2.27
	Width	m	1.14	1.14
Tire size	Diameter	mm	381	381
	Width	mm	127	127
Hydraulic system pressure		MPa	24	24
System voltage (DC)		V	24	24
Vehicle speed	Retracted state	km/h	3.5	3.5
	Extended state	km/h	0.8	0.8
Gradeability		%	25	25
Max allowable wind speed		m/s	12.5	12.5
Max allowable tilt angle	Front/Rear	°	3	3
	Left/Right	°	1.5	1.5
Normal working noise		dB	≤80	≤80

Parameter		Unit	120XPRO	140XPRO
Dimensions	Length	m	2.48	2.48
	Width	m	1.15	1.15
	Height (folded guardrail)	m	1.92	2.05
	Height (unfolded guardrail)	m	2.49	2.62
Ground clearance		mm	100	100
Ground clearance (with enabled anti-rollover device)		mm	20	20
Total weight		kg	2710	3000
Working size	Max. platform height	m	10.00	11.80
	Max. working height	m	12.0	13.80
	Max. horizontal length	m	0.90	0.90
Safe working load		kg	320	320
Safe load for extended platform		kg	113	113
Max. working staff		Number of people	Indoors only – 2 / Outdoor - 1	Indoors only - 2
Wheelbase		m	1.86	1.86
Wheel track		m	1.02	1.02
Turning radius	Inner wheel	m	0	0
	Outer wheel	m	2.2	2.2
Max allowable lateral force		N	400	400
Control voltage (DC)		V	24	24
Platform size	Length	m	2.27	2.27
	Width	m	1.14	1.14
Tire size	Diameter	mm	381	381
	Width	mm	127	127
Hydraulic system pressure		MPa	24	24
System voltage (DC)		V	24	24
Vehicle speed	Retracted state	km/h	3.5	3.5
	Extended state	km/h	0.8	0.8
Gradeability		%	25	25
Max allowable wind speed		<i>mis</i>	25.5	0
Max allowable tilt angle	Front/Rear	°	3	3
	Left/Right	°	1.5	1.5
Normal working noise		dB	≤80	≤80

Parameter		Unit	160X	160XS
Dimensions	Length	m	2.84	2.84
	Width	m	1.4	1.25
	Height (folded guardrail)	m	2.05	2.05
	Height (unfolded guardrail)	m	2.62	2.62
Ground clearance		mm	100	100
Ground clearance (with enabled anti-rollover device)		mm	20	20
Total weight		kg	3240	3240
Working size	Max. platform height	m	13.7	13.7
	Max. working height	m	15.7	15.7
	Max. horizontal length	m	0.90	0.90
Safe working load		kg	230	230
Safe load for extended platform		kg	113	113
Max. working staff		Number of people	Indoors only - 2	Indoors only - 2
Wheelbase		m	2.23	2.23
Wheel track		m	1.27	1.12
Turning radius	Inner wheel	m	0	0
	Outer wheel	m	2.70	2.65
Max allowable lateral force		N	400	400
Control voltage (DC)		V	24	24
Platform size	Length	m	2.64	2.64
	Width	m	1.14	1.14
Tire size	Diameter	mm	381	381
	Width	mm	127	127
Hydraulic system pressure		MPa	24	24
System voltage (DC)		V	24	24
Vehicle speed	km/h	km/h	3	3
	km/h	km/h	0.8	0.8
Gradeability		%	25	25
Max allowable wind speed		<i>mis</i>	0	0
Max allowable tilt angle	Front/Rear	°	3	3
	Left/Right	°	1.5	1.5
Normal working noise		dB	≤80	≤80

### 3 Safety rules

Failure to follow the instructions and safety rules in this manual may result in death or serious injury.

#### 3.1 Overview

Whether you are the owner, user or operator of the machine, before operating it for the first time, you must read through and thoroughly and properly understand the contents of this manual; and operate the machine according to the operation procedures under the supervision of qualified personnel with practical operating experience before operating it independently.

Most of the accidents that occur during the operation, maintenance and repair process are caused by the failure to follow the basic safety operation procedures and precautions. If the potential safety hazards are analyzed and corresponding safety measures taken before operation, most accidents can be completely avoided. Therefore, before operation, an evaluation should be made by a safety officer who is trained with the ability to analyze the potential safety hazards and remind the operator to take the necessary countermeasures to avoid them.

Before operating the machine, it is necessary to confirm that the personal protective devices listed in the table below are properly worn and intact.

Anti-falling safety rope	Protective gloves	Helmet	Safety shoes
--------------------------	-------------------	--------	--------------

#### 3.2 Instructions on signs



The meanings of the symbols, color codes and text used in the product labels this safety warning sign is contained in most safety statements.

It means that precautions should be taken at all times otherwise your safety will be at risk. Read and follow the information contained in the safety warning signs.



It is used to indicate that there is an emergency hazard which may cause death or serious injury.



It is used to indicate that there is a potential hazard which may cause death or serious injury.



It is used to indicate that there is a potential hazard which will cause minor or moderate injury.

#### Caution

It is used to indicate that there a risk of damage to the power unit, personal property or environment, or improper operation of the machine.

#### 3.3 Accident notice

Immediately notify our company if any accidents related to the machines from SIMAQ occur. Contact LIS and tell LIS all necessary details related to the accident by telephone even if no personal injuries or property damage were caused by the accident. In case of any failure to notify the manufacturer within 48 hours after an accident related to our machines; it may invalidate the product warranty.

#### Caution

After any accident, the machine should be thoroughly checked. Test all functions from the ground controller first and then from the platform controller. The lifting height should not exceed 3m until all damage is repaired and all controllers act correctly.

### 3.4 Risk of electrical shock

This machine is not insulated and has no electric shock protection.

All operators and managers should follow the relevant national or local regulations on the minimum safety distance of live conductors above ground. If there are no such requirements, the operators and managers should follow the requirements on the minimum safety distance listed in the table.



**Risk of electrical shock.**

- Follow the relevant government rules and always keep a safe distance from power cables and electrical equipment, as shown in the following table.
- Take the platform movement and wire swinging or sagging into account, take care in strong or gusty winds, and do not operate the machine in lightning or heavy rain.
- Stay away from the machine if the machine contacts live wires. Before the power is cut off, personnel on the ground or platform are must not touch or operate the machine.
- Do not use the machine as a ground wire during welding and polishing operations.

#### Min. safe distance of live conductors

Voltage Range (Phase-Phase, kV)	Min. Safe Distance
0-50	3 (10)
50-200	5 (15)
200-350	6 (20)
350-500	8 (25)
500-750	11 (35)
750-1,000	14 (45)

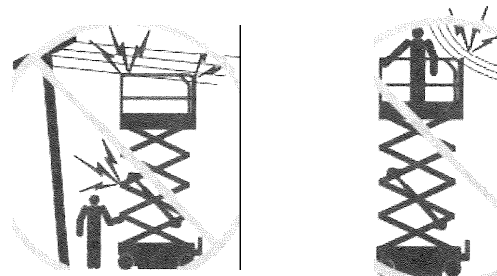

### 3.5 Danger of rollover.

#### Max. load capacity of the platform

Model	Max Load Capacity	Max Load Capacity of Extensible Platform	Max Number of People	Max Manual Operating Force
140XPRO	320kg	113kg	Indoors only - 2	Indoors only - 400N

#### Danger of rollover

- The total weight of personnel, equipment and materials on the platform must not exceed the maximum load capacity of the platform.
- The platform can only be lifted or extended when the machine is on solid and flat ground.
- Do not use the tilt alarm as a level indicator. The tilt alarm on the platform will sound only when the machine is severely tilted. If the tilt alarm sounds, the operator should

platform very carefully and then move it to a solid and flat surface. Do not alter the level or limit switch.

- When the platform is lifted, the driving speed should not exceed 0.8 km/h.
- Do not drive the platform on an uneven or unstable ground/surface or in other dangerous conditions when the platform is lifted.
- Do not operate the machine or increase the surface area of the platform or load during strong or gusty winds. The machine stability will be reduced if the area exposed to the wind is increased.
- Take care and drive the platform slowly when it is traveling on uneven ground or on a gravelly, unstable or slippery surface, close to an entrance or on a steep slope.
- Do not drive the machine on slopes where the maximum gradeability of the machine will be exceeded. For the machine in the retracted state, 25% of the maximum gradeability (14°) applies.
- Do not push or pull any objects outside the platform. The allowable maximum lateral force: indoors - 400N; outdoors - 200N.
- Do not change any parts that may affect the safety and stability of the machine.
- Do not use replacement parts of weights or specifications which are different from the original key parts as it may affect the machine stability.
- Do not modify or alter the mobile elevating work platform without the manufacturer's prior written permission.
- It will increase the platform weight or surface area or carrying load if the operator installs any additional devices for placing tools or other materials on the platform and guardrail.
- Do not place or tie any overhanging loads on any part of this machine.
- Do not place ladders or scaffolds against the platform or lean against any part of the machine.
- Do not use the machine on moving or movable surfaces or vehicles. Ensure that all tires are in good condition and the tire nuts are tightened.
- Do not use the platform to push other machines or objects.
- Do not let platform contact any adjacent objects.
- Do not tie the platform with ropes or other materials to any adjacent objects.

- Do not place the load outside the platform.
- Do not use the platform controller to lower the platform if it is caught, stuck, or unmovable because of other objects nearby. If it is intended to use the ground controller to lower the platform, no operation should be taken before all personnel have left the platform.
- Do not use a battery of a lower weight than the original one. The battery not only provides power, but also acts as a counterweight, so it is essential to maintain the machine stability. The weight of each battery for 140XPRO model must be at least 35kg.
- Do not operate the machine when the left/right side door is open.

### 3.6 Hazards in the work environment

Check the workplace for possible hazards before or during operating the machine and pay attention to the hazards in the work environment including flammable and explosive gases or dust, etc.



#### Unsafe workplace

- Do not operate the machine on the surface, edges or other places which cannot bear the machine weight. The platform can only be lifted or extended when the machine is on solid and flat ground.
- Do not use the tilt alarm as a level indicator. The tilt alarm will sound only when the machine is severely tilted.
- If the tilt alarm sounds when the platform is lifted, the operator should lower the platform very carefully, rather than operate the horizontal or limit switch.
- When the platform is lifted, the driving speed should not exceed 0.8 km/h.
- Do not operate the machine in strong or gusty winds if the machine is used outdoors. Do not lift the platform when the wind speed exceeds 12.5 m/s. Immediately lower the platform if the wind speed exceeds 12.5m/s when it is lifted and do not continue operation.

- Do not drive the platform on an uneven or unstable ground/surface or in other dangerous conditions when the platform is lifted.
- Take care and drive the platform slowly when it is retracted and traveling on an uneven ground or on a gravelly, unstable or smooth surface, close to an entrance or on a steep slope.
- Do not drive or lift the machine on slopes, steps or arches where the maximum gradeability of the machine may be exceeded.

Beaufort	Meten; Per	Miles Per	Description	Ground Situation
0	0 - 0.2	0 - 0.5	Calm and	Smoke rises vertically.
1	0.3 - 1.5	1-3	Light winds	Smoke drift shows wind direction.
2	1.6 - 3.3	4-7	Light	Wind can be felt on face. Leaves rustle.
3	3.4 - 5.4	8 -12	Gentle	Flag waves.
4	5.5 - 7.9	13 -18	Gentle	Dust and loose paper scattered and
5	8.0 - 10.7	19 - 24	Fresh	Small trees sway.
6	10.8 -13.8	25 - 31	Strong	Umbrellas are hard to use, large
7	13.9 - 17.1	32 - 38	Moderate	Trees sway. Difficult to walk in the
8	17.2 - 20.7	39 - 46	Strong gale	Twigs and branches break off trees.
9	20.8 - 24.4	47- 54	Severe gale	Roof tiles blow off buildings.

### Caution

Maximum gradeability - 25% The maximum gradeability applies to the machine with the platform retracted.

The gradeability refers to the maximum allowable tilt angle when the machine is on solid ground and the platform is carrying only one person. The rated gradeability of the slope will be reduced when the platform increases in weight.

### 3.7 Danger of unsafe operation

The machine should be operated in strict accordance with the requirements of this manual and the maintenance manual, or if there are stricter industrial or local regulations, the latter shall prevail.



### Danger of unsafe operation

- Do not push or pull any objects outside the platform. Maximum allowable lateral force: indoors - 400 N; outdoors - 200N.
- Do not change any parts that may affect the safety and stability of the machine.
- Do not use replacement parts of weights or specifications which are different from the original key parts as it may affect the machine stability.
- Do not modify or alter the mobile elevating work platform without the manufacturer's prior written permission.
- It will increase the platform weight or surface area or carrying load if the operator installs any additional devices for placing tools or other materials on the platform and guardrail.
- Do not place ladders or scaffolds against the platform or lean against any part of the machine.
- Do not use the machine on moving or movable surfaces or vehicles. Ensure that all tires are in good condition and the tire nuts are tightened.
- Do not place or add any overhanging loads on any part of this machine.
- Do not use the machine as a crane.
- Do not use the platform to push other machines or objects.
- Do not make platform contact or tie it to any adjacent objects.
- Do not place the load outside the platform.
- Do not use the platform controller to lower the platform if it is caught, stuck, or unmovable because of other objects nearby. If it is intended to use the ground controller to lower the platform, no operation should be taken before all personnel have left the platform.

### 3.8 Danger of falling

The machine should be operated in strict accordance with the requirements of this manual and the maintenance manual, or if there are stricter industrial or local regulations, the latter shall prevail.

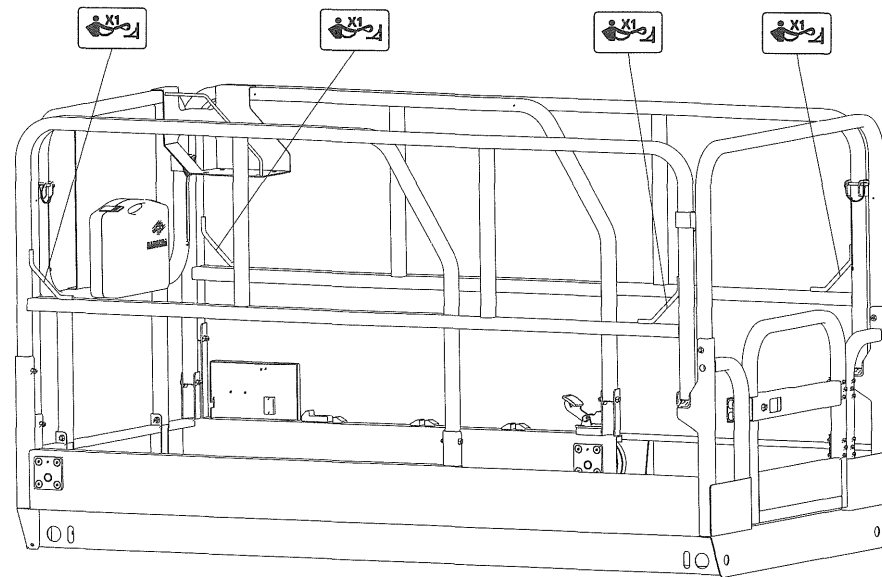

Seat belt hook layout



### Danger of falling

\*People on the platform must wear safety belts or use safety facilities that comply with government regulations. Tie the lanyard to the tie-down point of the platform, only one person should perform this operation at each tie-down point.

- Do not sit, stand or climb on the platform guardrail. Stand on the platform floor firmly at all times.
- Do not get down from the platform when the platform is lifted.
- Keep the platform floor unobstructed.
- Do not enter or exit the platform unless the machine is fully retracted.
- Close the access door before operation.
- Do not operate the machine if the guardrail is not installed correctly or the access door is not closed.

### 3.9 Danger of collision

The machine should be operated in strict accordance with the requirements of this manual and the maintenance manual, or if there are stricter industrial or local regulations, the latter shall prevail.



### Danger of collision

- Pay attention to the sight range and blind spots when moving or operating the machine.
- Check the workplace to avoid obstacles or other possible hazards above your head.
- **Take care when using the platform controller** and ground controller. The colored direction arrows indicate the driving, lifting/lowering and steering function of the machine.
- The user must abide by the rules on personal protective equipment for users, workplace rules and government rules (on safety helmets, safety belts and gloves).
- The machine must be placed on a level surface or fixed securely before the brake is released.
- The platform can only be lowered when there are no people and obstacles under it.
- Control the driving speed based on ground conditions, congestion, gradient, location of people, and any other factors that may cause a collision.
- Do not operate the machine on the possible traveling route of any crane or moving gantry unless the crane controller is locked or precautions have been taken to prevent any potential collision.
- Do not put your hands and arms close to parts where they may get jammed or stuck.
- Do not operate under the platform or near the scissor arms when the safety bar is not in the proper position.
- Use good judgment and planning when using the controller to operate the machine on the ground. Maintain a proper distance between the operator, machine and fixed objects.
- Do not drive in a dangerous manner when operating the machine.
- Do not drive in a dangerous manner when operating the machine.

### 3.10 Danger of jamming

There is a potential danger of jamming when the machine is moving. Keep your body and clothes a safe distance away from the machine when the machine is running.



<b>Danger of jamming</b>
<ul style="list-style-type: none"><li>• Do not put your hands and arms close to parts where they may become jammed or stuck.</li><li>• Do not operate under the platform or near the scissor arms when the safety bar is not in the proper position.</li><li>• Use good judgment and planning when using the controller to operate the machine on the ground and keep a safe distance between the operator and the machine/fixed objects.</li></ul>

### 3.11 Danger of explosion/fire

<b>Danger of explosion/fire</b>
<ul style="list-style-type: none"><li>• Do not use the machine, charge the battery or refuel the lift in a dangerous area or where flammable and explosive gases or particles may exist.</li></ul>

### 3.12 Danger of machine damage

The operators should follow the requirements for the use and maintenance of parts in this manual and the maintenance manual, otherwise it will cause damage to the machine.

<b>Danger of machine damage</b>
<ul style="list-style-type: none"><li>• Do not use damaged or faulty machines.</li><li>• Before each work shift, a thorough check should be carried out before operating the machine and all functions should be tested. Mark damaged or faulty machines and stop operations immediately.</li><li>• Ensure that all maintenance operations have been performed in accordance with the regulations in this manual and the corresponding maintenance manual.</li></ul>

- Ensure that all labels are properly positioned and easily identifiable.
- Ensure that the operation manual and maintenance manual are intact, easy to understand, and kept in the file case on the platform.

### 3.13 Danger of physical injury

The operators should follow the requirements for the use and maintenance of parts in this manual and the maintenance manual, otherwise it will cause damage to the machine.

<ul style="list-style-type: none"><li>• Unsafe operation can be dangerous.</li><li>• Do not operate the machine when there is hydraulic oil leakage. Hydraulic oil leaks may penetrate and burn the skin.</li></ul>

### 3.14 Battery hazards



<ul style="list-style-type: none"><li>• The battery contains sulfuric acid and can produce an explosive mixture of hydrogen and oxygen. Keep all objects (including cigarettes/materials which can produce smoke) that can cause sparks or flames away from the battery to prevent an explosion.</li><li>• Do not use tools that may cause sparks to contact the battery terminals or cable clamps.</li><li>• Wear protective clothing and glasses when working on the battery. Take off all rings, watches and other jewelry.</li><li>• Prevent the acid in the battery from spilling or contacting the skin. If the battery acid leaks out, please use soda to neutralize it; if the battery acid contacts the skin, please rinse it with plenty of water and seek medical attention immediately.</li><li>• When lifting the battery, the number of operators and lifting methods should be correct and proper.</li><li>• Use the charger specified by the manufacturer to charge the battery.</li><li>• The charger can only be connected to a grounded two-phase AC power socket.</li><li>• Check whether the wires are damaged daily, and replace damaged ones before operation.</li></ul>

### 3.15 Hydraulic system hazards

<ul style="list-style-type: none"><li>• Do not touch the hydraulic system when it is at high temperature! Hot hydraulic oil may cause serious personal injury.</li><li>• Clean any spilled hydraulic oil thoroughly after the machine is shut down. Do not spill hydraulic oil on the floor. Clean any hydraulic oil off your skin once the maintenance and repairs are completed. Dispose of the used hydraulic oil in accordance with legal requirements.</li><li>• Do not plug leaking hydraulic oil with your hands. If there is a hydraulic oil leakage, relieve the system pressure first and carry out maintenance after the hydraulic oil has cooled down. Seek medical attention immediately in the event of any injuries caused by the hydraulic oil. Serious complications may occur if treatment is not provided immediately.</li></ul>

### 3.16 Welding and grinding safety

Before welding and polishing operations, welders must obtain permission from the authority which is responsible for the workplace management.

<ul style="list-style-type: none"><li>• Follow the manufacturer's recommendations for the proper welding procedures.</li><li>• Connect wires or cables for welding or polishing operations only after the power is turned off.</li><li>• The welding and polishing operation can only be carried out after the cables or wires are correctly connected.</li><li>• The machine should not be used as a ground wire during welding operations.</li><li>• Always make sure that the electric tools are all placed inside the work platform, never hang their wires on the guardrail of the work platform or in the work area outside the platform, never hang the electric tools directly by their wires.</li></ul>

### 3.17 Lock after use

1. Choose a safe parking location, which should be a solid and flat surface with no obstacles or heavy traffic.
2. Ensure the scissors are lowered to the bottom and all covers and doors are

closed and fastened securely.

3. Do not fully extend the hydraulic cylinder when the machine is powered off or idle for a long time.
4. Press and turn the "Emergency Stop Switch "on the platform control box to the "OFF" position.
5. Press and turn the "Emergency Stop Switch "on the ground control box to the "OFF" position.
6. Turn the "Key Switch on the ground control box to the "OFF" position and pull the key out to avoid unauthorized operation.
7. Turn off the power switch.
8. Charge the battery.

<b>Caution</b>
The power switch must be turned off after each use.

## 4. Lifting, fastening and towing

### 4.1 Lifting

Before lifting, confirm:

- Transport vehicles must be parked on level ground and fixed securely to prevent them from moving.
- Ensure the platform is lowered to the bottom, the extensible platform is retracted and the left- and right-side doors on the chassis are closed.
- Remove all loose parts from the machine.
- Prevent the guardrail from falling when folding it. Always hold the guardrail firmly when folding it. After folding, the guardrail should be fixed firmly to prevent moving.

### While lifting the platform.

- Ensure that the vehicle capacity, loading surface, belts or ropes are strong enough to carry the machine (see the section "Specifications").
- When using a forklift or crane to lift the machine, please use good judgment and planning to control the machine movement.

### Lifting with a crane

- The lifting slings can only be fastened to the designated tie-down point of the machine.
- Adjust the lifting slings based on the center of gravity of the vehicle to avoid any damage to the machine and keep

### Forklift requirements

- Use forklift notches on both sides of the ladder.
- Align the forks with the forklift notches.
- Drive the forklift forward until the forks are fully inserted.
- Lift the machine by 0.4m, and then tilt the forks back slightly to hold the machine securely.
- Make sure the machine is level when lowering the forks.

### 4.2 fastening and fixing

The machine must be securely fixed when it is transported with a crane or trailer to prevent accidental movement.

- Ensure the platform is lowered to the bottom, the extensible platform is retracted and the left- and right-side doors on the chassis are closed.
- Use wedges to support the wheels before transportation to prevent the machine from moving.
- Before transportation, turn the key switch to the "OFF" position and then remove the key.
- Check the machine thoroughly for loose or unfixed parts.
- Fasten and fix the machine on the transport vehicle through tie-down point of the chassis.
- Use at least 4 chains or belts.
- Ensure that the chains or belts have sufficient strength.
- Adjust the lock to prevent any damage to the chain.

### 4.3 Tow

The brake of this machine is engaged by default. Thus, when it has any faults or cannot be moved due to any damage, please do not tow it, proper transportation vehicles should be used.

Carry out a manual brake release operation before towing the machine. Do not move or tow a damaged machine on the ground, or it will damage the braking system.

- The machine must be placed on a level surface or fixed securely before the brake is released.
- Use wedges to support the wheels to prevent the machine from moving.
- Find the manual release brake valve located at the back of the chassis.
- Push the black hydraulic stop valve handle to cut off the oil return line.
- Push and pull the red brake release manual pump handle repeatedly until the pressure increases to the extent that it is difficult to push further.
- Pass the rigging through the tie-down point (towing hale) at the front of the chassis and it with the towing vehicle or tool.
- Tow the damaged machine to the designated maintenance
- If it is required to reset the brake, the operator just needs to pull the black hydraulic stop handle outward.

## 5 Checks before operation

### 5.1 Check the machine

In order to operate the machine safely and keep it in good condition, a thorough check must be made before it is started.

#### Basic principles

- The operator should be responsible for the pre-operation check and routine maintenance.
  - The pre-operation check is a visual inspection process, which is performed by the operator before each work shift. The purpose of the pre-operation check is to find obvious problems with the machine before the operator performs the function test.
  - The pre-operation check can also be used to determine whether routine maintenance is required. The operator can only perform the routine maintenance items specified in this manual.
- \*Refer to the list attached to the machine and parts and check each item and location for changes, damage, looseness or missing parts.
- Do not use damaged or altered machines. Mark the machine and stop using it if any damage or any changes to the original machine are found.
  - According to the manufacturer's regulations, only qualified service technicians can repair machine. After the maintenance, the operator must perform another pre-operation check before performing the function test.
  - According to the manufacturer's regulations and the requirements stated in the duty regular maintenance and inspections should be performed by qualified maintenance technicians.

#### Check items

- Ensure that the operation manual and maintenance manual are intact, easy to understand, kept in the storage case on the platform.
- Ensure that all labels and signs are clear and visible and stuck in the proper positions. section "Labels and Signs".
- Check for any leakage of hydraulic oil and its level. Add hydraulic oil as needed, do not overfill.

- Check for any leakage of battery electrolyte and its level. Add distilled water as needed.
- Check the following components or parts for any damage, improper installation, loose or missing parts, and unauthorized changes:
  - Electrical components, wiring and cables
  - Hydraulic power unit, oil tank, joints, hoses, hydraulic cylinders and valve blocks
  - Battery pack and its wiring
  - Drive motor and brake device
  - Brake release valve
  - Tires
  - Maintenance arm
  - Limit switch and horn
  - Alarm and indicator light
  - Platform access door
  - Anti-rollover device
  - Platform extension part
  - Platform control handle
  - Scissor arm pins and fasteners
  - Nuts, bolts and other fasteners
- Check the whole machine to find:
  - Cracks in welded joints or structural components
  - Dents or damage to the outer surface of machine
  - Serious rust, corrosion or oxidation
  - Ensure that all structural components and other key parts are complete, and all related fasteners and pins are in the correct position and fully tightened.

### 5.2 Checks before operation

The operator should check the workplace to see whether it is suitable for safe operation of the machine. The operator should perform the above check before moving the machine to the workplace.

It is the operator's responsibility to be aware of and remember the dangers and hazards in the

workplace to avoid them in the subsequent operations such as moving, installing and operating the machine.

### **Beware and avoid the following dangerous**

- \*Steep slopes or openings
- \*Protrusions, ground obstacles or debris
- \*Inclined surfaces
- \*Weak or slippery surfaces
- \*Aerial obstacles and high-voltage wires
- \*Dangerous locations
- \*Surface supports that are not strong enough to carry the full load on the machine
- \*Gusts and strong winds
- \*Unauthorized on-site personnel
- \*Other possible unsafe conditions

## **6. Functional test before**

### **Basic principles**

- The purpose of the functional test to find functional defects or faults before using the machine. The operator must test all functions of the machine step by step according to the instructions.
- Do not use faulty machines. Mark the machine and stop using it in case of any faults. According to the manufacturer's regulations, only qualified service technicians can repair the machine.
- After maintenance, the operator must perform the pre-operation inspections and functional test again before using the machine.

### **Preparations before test**

- Choose a test area that is solid, flat and free of obstacles.
- Ensure that the battery pack is connected.
- Turn on the main power switch.

### **6.1 Test the ground controller**

1. Pull out the red "Emergency Stop" switches on the platform and the ground and set them to the "ON" position.
2. Turn the key switch to the ground control position.

Result: The relevant indicator lights are on and no error information is displayed.

### **Test emergency stop**

1. Press the red "Emergency Stop" switch on the ground and place it to the "OFF" position. Result: all functions will be turned off.
2. Pull out the red "Emergency Stop" switch and set it to the "ON" position.

### **Test the lifting and lowering function**

1. Start the lifting function. Result: The platform should be lifted.
2. Start the lowering function. Result: The platform should be lowered and the lowering alarm should be sounded.

## 6.2 Test the platform control handle

1. Turn the key switch to the ground control position.

Result: The relevant indicator lights are on and no error information is displayed.

### Test emergency stop function

1. Turn the ground control switch to the platform control handle.
2. Press the red "Emergency Stop" switch on the platform and set it to the "OFF" position.  
Result: all functions will be turned off.
3. Pull out the red "Emergency Stop" switch and set it to the "ON" position.

### Test the horn

1. Sound the horn.

Result: The horn should be sounded.

### Test enable switch

1. Do not press the enable switch of the control handle. Move the control handle in the direction of the arrow.

Result: All functions will be turned off.

### Test the lifting and lowering function

1. Press the lifting button and it will light up.
2. Hold and push the control handle forward in the direction of the arrow to activate the lifting function.

Result: The platform should be lifted and the anti-rollover device should be enabled.

3. Release the control handle.

Result: The platform will stop lifting.

4. Hold and push the control handle backward in the direction of the arrow to activate the lowering function.

Result: The platform should be lowered and the lowering alarm should be sounded.

**ATTENTION:** All tests should be completed in one cycle.

### Test steering function

1. Press the driving and steering button and it will light up.
2. Press and hold the left steering button on the control handle.

Result: The tires turn to the left.

3. Press and hold the right steering button on the control handle.

Result: The tires turn to the right.

### Test the driving and braking function

1. Press the driving and steering button and it will light up.
2. Slowly push the proportional control handle forward until the machine starts to move based on the direction arrow on the control panel, and then return the handle to the center position.
3. Slowly push the proportional control handle backward until the machine starts to move based on the direction arrow on the control panel, and then return the handle to the center position.

Result: The machine should move forward and then stop.

Result: The machine should move backward and then stop.

**ATTENTION:** The brakes must be able to stop the machine and ensure it will not roll down on any slope that the machine can climb.

### Test the driving speed limit

1. Press the lifting button and it will light up.
2. Lift the platform about 2m until the anti-rollover device is enabled.

Result: The anti-rollover device (located in the lower part of the chassis, one on each side) should be enabled.

3. Press the traveling and steering button, slowly operate the drive control handle to the maximum position.

Result: The machine travels at a speed of at least 10m per 45s.

**ATTENTION:** If it is less than 10m per 45s, the operator should stop the machine and mark it, and then the maintenance personnel should check or modify the parameters.

## 6.3 Test the safety function

### Test the manual brake release function

The manual brake release valve is mounted on the rear of the frame.

1. Press the black reversing valve (1).
2. Push the red manual pump (2) repeatedly to release the brake.

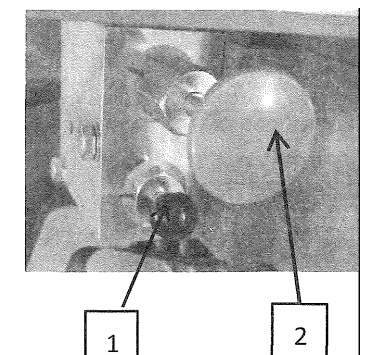

3. Reset the reversing valve (1) after the test is completed.

### Test emergency lowering

1. Start the lifting function and lift the platform to a certain height.
2. Pull out the emergency lowering handle (on the rear of the frame).

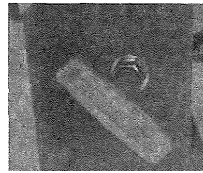

Result: The platform should be lowered and will stop lowering after releasing the handle. The alarm does not sound when the platform is lowered.

### Test level sensor

**Attention** Use the platform control handle to control the equipment on the ground, do not stand inside the platform to operate.

1. Lower the platform safely.
2. For 65X, 78X, 80X and 100X:

Place two wooden blocks with the dimensions 120mmx25mm (WxH) under the two wheels on the left/right side of the machine, and then drive the machine onto these two wooden blocks.

For 80X, 100X, 120X and 140X:

Place two wooden blocks with the dimensions 150mmx35mm (WxH) under the two wheels on the left/right side of the machine, and then drive the machine onto these two wooden blocks.

For 160X and 160X:

Place two wooden blocks with the dimensions 150mmx40mm (WxH) under the two wheels on the left/right side of the machine, and then drive the machine onto these two wooden blocks.

3. Switch the driving function to the platform lifting/lowering function and press the handle to lift the platform by about 2m.

Result: The platform should stop moving and the tilt alarm should be sounded. "LL" will be displayed on the platform and ground control panel.

4. Lower the platform, switch to driving function, remove the working platform, and then the wooden blocks.

5. For 65X and 78X:

Place two wooden blocks with the dimensions 120mmx45mm (WxH) under the two wheels on the front/rear of the machine, and then drive the machine onto these two wood blocks.

For 80X, 100X, 80X, 100X, 120X and 140X:

Place two wooden blocks with the dimensions 150mmx100mm (WxH) under the two wheels on the front/rear of the machine, and then drive the machine onto these two wooden blocks.

For 160X and 160X:

Place two wood blocks with the dimensions 150mmx120mm (WxH) under the two wheels on the front/rear of the machine, and then drive the machine onto these two wooden blocks.

6. Switch the driving function to the platform lifting/lowering function and press the handle to lift the platform for about 2m.

Result: The platform should stop moving and the tilt alarm should be sounded. "LL" will be displayed on the platform and ground control panel.

7 ... Lower the platform, switch to driving function, remove the working platform, and then the wooden blocks.

### Test the anti-rollover device

**Attention** When the platform is lifted, the anti-rollover device should be enabled automatically. The anti-rollover device activates two limit switches to restrict the machine's travel.

When the platform is lifted to the position where the fork seat leaves the anti-rollover device lever, if the anti-rollover device is not enabled, the alarm will be sounded and the machine cannot be lifted or driven.

1. Lift the platform.

Result: When the platform is lifted to the position where the fork seat leaves the anti-rollover device lever, the anti-rollover device should be enabled automatically.

2. Push the left/right anti-rollover plate hard.

Result: The anti-rollover plate cannot be turned inward.

3. Lower the platform.

Result: The anti-rollover device should retract automatically.

4. Place a wooden block with the dimensions 100mmx50mmx50mm (LxWxH) under the guard plate of the anti-rollover device and then lift the platform.

Result: When the platform is lifted to the position where it is 2m off the ground, the alarm will be sounded and the platform and ground control panels will display the digits "18". The machine

cannot be lifted or driven.

Lower the platform and remove the wooden block.

## 7. Operation Instructions

### Basic principles

\*The "Operation instructions" section provides specific instructions for all aspects of machine operation. It is the operator's responsibility to follow all safety rules and instructions in the operation manual.

\*It is unsafe and even dangerous to use this machine for purposes other than lifting people and tools to the aerial workplace.

Only fully trained and authorized personnel should operate the machine.

\*If more than one operator uses the same machine at different times in the same work shift, they must all be qualified operators and follow all safety rules and instructions in the operation manual. This means that each new operator should conduct pre-operation check, functional tests and workplace check before using the machine.

### 7.1 Emergency measures

#### Emergency stop

\*Press the red "Emergency Stop" button on the ground control panel or platform control handle inward to the "OFF" position, and all functions will be stopped.

\*To restore any operating function, please pull out the "Emergency Stop" button to the "ON (Open)" position and turn the power switch to the "ON" position.

#### Emergency Lowering

\*Pull out the emergency lowering

#### Manual brake release

\*Press the black reversing valve.

\*Push the red manual pump repeatedly to release the brake.

### 7.2 Operate on the ground

\*Turn the key switch to the ground control position.

\*Pull out the red "Emergency Stop" button and set it to the "ON (Open)" position.

#### Adjust the platform position

1. Operate the lifting/lowering button based on the mark on the control panel.

**Attention** The driving and steering functions cannot be used through the ground control panel.

### 7.3 Operate on the platform

\*Turn the key switch to the platform control position.

\*Pull out the "Emergency Stop" buttons on the platform and the ground and set them to the "ON (Open)" position.

\*The operator must wear the safety belt as required and fasten it to the hook for the safety belt on the platform.

#### Adjust the platform position

1. Press the lifting button and it will light up.
2. Press and hold the enable switch on the control handle.
3. Operate the handle based on the lifting/lowering icon on the control panel.

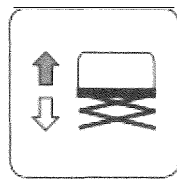

#### Steering

1. Press the driving and steering button and it will light up.
2. Hold the enable switch on the control handle.
3. Use the thumb rocker switch on the top of the control handle to turn the steering wheel.

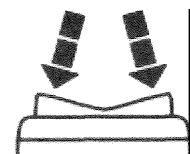

**Attention** Use the color direction arrows of the platform control handle to determine the wheel turning direction.

#### Drive

1. Press the driving and steering button and it will light up.
2. Press and hold the enable switch on the control handle.
3. Speed up: Slowly operate the handle to make it deviate from the center position.
4. Slow down: Slowly loose the control handle to the center position.
5. Stop: Return the control handle to the center position or release the enable switch.

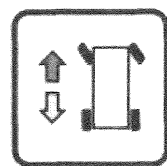

Use the color direction arrows on the platform control handle to determine the driving direction of machine.

The driving speed of the machine is restricted when the platform is lifted up to two meters.

**Attention** The battery state will affect the machine performance. When "Low Battery" is displayed on the platform control panel, the driving speed and lifting speed of the machine will be reduced.

#### Select driving speed

In the retracted position, the driving controller can work in two different driving speed modes.

When the low-speed button (tortoise speed indicator) lights up, the low driving speed mode is activated. If it does not light up, the machine will run in high driving speed mode by default.



Press the low-speed button to select the required driving speed.

**Attention** When the platform is lifted to the position where the anti-rollover device is enabled, the low-speed button (tortoise speed indicator) lights up, indicating that the lift is running in low driving speed mode.

#### Battery level display

Check the battery level from the LED on the platform control handle.

Table of battery levels

Battery Level	Remaining Capacity Ratio	Description
6 bars	90-100%	Full battery
5 bars	70%	70% Battery capacity
4 bars	50%	50% Battery capacity
3 bars	30%	30% Battery capacity
2 bars	20%	The battery is low and must be charged immediately.
1 bar	10%	Extremely low battery, the platform slows down or even stops working.

### 7.4 Extend and retract the platform

#### Extend and retract the platform

1. Depress the pedal.
2. Hold and carefully push the extensible platform guardrail to extend platform.

**Attention** Do not stand on the extended part of the platform when extending it. The extensible platform can be positioned at the three slots, do not stand on the extensible platform

when it is not fixed.

### **Unfold and fold the**

The platform guardrail can be folded for ease of transportation. Unfold the platform guardrail as required. The platform guardrail system includes a folded guardrail part for the extensible platform and a folded guardrail part for the fixed platform. All parts should be fixed in place by several D-shaped pins.

1. Lower the platform completely and retract the extensible platform.
2. Remove the platform control handle.
3. Pull out the D-shaped pins and fold the front guardrail and the side guardrails of the extensible platform.
4. Open the door carefully and move to the ladder or the ground.,
5. Pull out the D-shaped pins and fold and fasten the side guardrails of the extensible platform.
6. Pull up and fold the door and rear guardrail together as an integral part.

Unfold the platform guardrail reversing the steps stated above and then fit the O-shaped pins into the slots to ensure safe and correct installation.

**Attention** Do not place your hands in any positions where they may get stuck or jammed by the guardrails before folding or unfolding the guardrails.

### **7.5 Maintenance arm**

lift all maintenance arms before maintenance or repairs on the machine. Make sure there is no load on the platform before using the maintenance arms.

1. Use the ground control panel to lift the platform to the point where the spacing between the upper and lower scissor shaft sleeves is greater than the length of the maintenance arm.
2. Lift the maintenance arm, move it to the middle of the scissor shaft sleeves, and rotate it upward to make it vertical.
3. Lift the maintenance arm, move it to the middle of the scissor shaft sleeves, and rotate it downward to make it vertical (applicable to machines with two maintenance arms).
4. Lower the platform until the scissor shaft sleeves and the maintenance arm fit well with each other.

### **7.6 Battery and charger**

- \*Do not use an external charger or high voltage charger.
- \*Charge the battery in a well-ventilated area.
- \*Use the correct AC input voltage indicated on the label for charging.
- \*Only batteries and chargers approved by HANGCHA can be used.

#### **Charging the battery (standard lead-acid batteries)**

1. Make sure that the battery is connected before charging.
2. Open the battery side cover which needs to be kept open during the charging process.
3. Remove the battery vent cover and check the electrolyte level of the battery. If the electrolyte level is low, the operator should add enough distilled water through the filling port on the top of the battery to make the distilled water cover the electrode plate. Do not overfill.
4. Fit the ventilation cover.
5. Connect the charger to a grounded AC circuit.
6. The charger will give a prompt when the battery is fully charged.
7. Check the battery electrolyte level after it is fully charged. If the electrolyte level is low, the operator should add distilled water through the filling port on the top of the battery. Do not overfill.

#### **Charging the battery (maintenance-free batteries or lithium-ion batteries)**

1. Make sure that the battery is connected before charging.
2. Open the battery side cover which needs to be kept open during the charging process.
3. Connect the charger to a grounded AC circuit.
4. The charger will give a prompt when the battery is fully charged.

## 8. Maintenance

See the maintenance manual for the specify maintenance items and procedures.

### 1 Instructions on maintenance

\*It is necessary to perform regular checks and maintenance to keep the performance of the machine at optimum.

\*Checks and maintenance are often neglected, so it is better to find the problems early and solve them in time.

\*When changing or adding oil, do not use oil which is not the same as the original. \*The waste oil and fluid and the old lithium-ion battery should be disposed of in accordance with the local laws and regulations, rather than disposed of at will.

\*Develop a comprehensive maintenance and repair plan.

\*Complete records should be made after each maintenance and repair.

\*Only trained and approved service personnel can repair the machine.

\*Unless otherwise detailed, the operator should perform maintenance according to the following requirements:

1. The platform should be placed on a flat and level surface.
2. The platform should be stationary.
3. Turn the key switch of the ground controller to the "OFF" position and pull out the key. Then

cut off all power to the machine.

### 8.2 Table of maintenance schedules

There are four maintenance cycles for this machine including daily, quarterly, semi-annually and annually. Definitions are listed as follows:

Maintenance item	Maintenance Cycle
A	Once every 8 working hours (or daily)
A+B	Once every 250 working hours (or quarterly)
A+B+C	Once every 500 working hours (or semi-annually)
A+B+C+D	Once every 1,000 working hours (or annually)

### 8.3 Maintenance report

\*The Maintenance Report is divided into four sections (A, B, C, and D) based on the maintenance items, maintenance cycle and requirements.

\*The Maintenance Report contains all the maintenance record sheets.

\*Copy the Maintenance Report for each check. The maintenance report should be kept for at least 10 years or until the machine is out of service or as requested by the machine owner/company.

\*Use the table below to record the results. After completing each section of the report, check the corresponding box to mark it.

\*If it is "Fail" for any check item, the operator must stop the machine, recheck it after repair and check the "Pass After Repair" box to mark it. Select the check items based on the check type.

Maintenance Record Sheet A			
Item	Pass	Fail	Pass After Repair
A-1 Check the manual			
A-2 Check the labels and signs			
A-3 Check the parts and components			
A-4 Check the hydraulic oil			
A-5 Check the battery level			
A-6 Check the functions			
A-7 Check the emergency lowering function			
A-8 Check the braking function			
A-9 Check the tilt protection system			
A-10 Check the pothole protection system			
A-11 Check the limit switch			
A-12 Test the lifting/lowering time			
A-13 Test the driving speed			
A-14 Test the overload device (optional)			
A-15 Carry out maintenance every 30 days			

Maintenance Record Sheet B			
Item	Pass	Fail	Pass After Repair
B-1 Check the wires			
B-2 Check the wheels and tires			
B-3 Check the battery			
B-4 Check the hydraulic oil			
B-5 Check the hydraulic oil tank			
B-6 Check the manual brake release function			

Maintenance Record Sheet C			
Item	Pass	Fail	Pass After Repair
C-1 Replace the air filter			

Maintenance Record Sheet D			
Item	Pass	Fail	Pass After Repair
D-1 Replace the oil return filter			
D-2 Change the hydraulic oil			
D-3 Check the bushings and sliding blocks			
D-4 Check the key structural parts			