

HONDA

GENERAL PURPOSE ENGINE

**GX390H1
GX390H2**

PARTS CATALOGUE

3

FOREWORD INDEX

1

ENGINE GROUP

2

PART NUMBER INDEX

3

PART NAME INDEX

4

Instruction for use of parts catalogue

- **This parts catalogue was prepared based on the latest information available as of December 10, 2019.**
 - See the parts catalogue news for any revision that is made after December 10, 2019.
- **Always specify the part number when ordering a part.**
 - Check the model, type, serial numbers, color, maker, and the size as needed before ordering a part.
 - Note that the illustrations (part drawings) can differ from the actual parts in shape. They are given just to help you to refer to the parts.
- **When modifications or additions to this parts catalogue are made, a revised edition will be issued at an appropriate time, with successively progressing revision numbers on the cover. We recommend obtaining such revisions in order to keep your parts catalogue up-to-date at all times. To check whether a parts catalogue revision has been issued, please contact your Honda distributor.**

Initial version issue date May 18, 2007
Honda Motor Co., Ltd.

CONTENTS

	Page
● Instruction for use of parts catalogue	1
● How to refer to the part information	2
● Part catalogue structure	3
● When the parts were revised.....	4
● Abbreviations used in the parts catalogue.....	4
● How to check the part block and serial numbers.....	5
● Models, parts catalogue codes and applicable serial numbers.....	6
● Features of each type.....	10
● Fuel hose, general purpose hoses and vinyl hose	18
● FLAT RATE SERVICE TIME	19
● Illustrated index	24
● ENGINE GROUP.....	28
● PART NO. INDEX.....	107
● PART NAME INDEX.....	111

How to refer to the part information

A Reference with "Illustrated index"

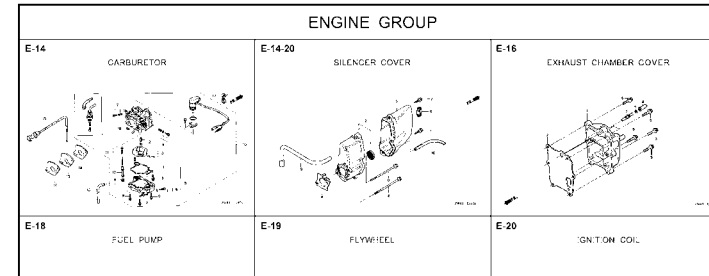

B Reference with "Part number index"

PART NO. INDEX				
Part Number	Page Ref.	Part Number	Page Ref.	Pi
06000		15212-ZW9-000	49 7	17583
		15220-ZW9-003	49 8	17583
06316-ZW9-000	104 1	15332-ZW9-000	74 2	17611
		15332-ZW9-A30	76 2	17611
11000		15400-PFB-004	46 5	17612
		15422-ZW9-000	49 9	17620
11300-ZW9-000	46 1	15473-881-000	49 10	17620
11300-ZW9-800	46 1	15474-ZW9-000	49 11	17624
11340-ZW9-000	46 2	15611-921-000	45 6	17650
11342-ZW9-000	46 3	15655-ZW9-000	46 6	17650
11381-ZW9-003	47 1			17660
				17661
12000		16000		
		16010-ZV4-005	55 1	17665
12000-ZW9-000ZA	46 4	16011-ZV4-005	55 2	17670
12155-ZV4-A00	48 1	16013-ZW9-003	55 3	17680
12166-ZW9-000	45 1	16016-ZW9-003	55 4	17701
12209-GB4-681	51 1	16016-ZW9-721	55 4	17701
12210-ZW9-000ZA	45 2	16023-ZW9-003	55 5	17701
12216-ZE2-300	74 1	16024-ZV4-650	55 6	17701
		16028-ZV4-650	55 7	17702

C Reference with "Part name index"

PART NAME INDEX		
Part name	Page	Ref.
[A]		
ABSORBER, FUEL	80	5
ARMATURE COMP.	62	7
ARM COMP., LINK JOINT	102	18
ARM COMP., SHIFT LINK	102	14
ARM COMP., TILT	97	20
ARM, FUEL PUMP ROCKER	51	4
ARM, REVERSE LOCK	97	18
ARM, SHIFT LINK	92	7
ARM, STOPPER	52	12
ARM, THROTTLE REMOTE	92	6
ARM, VALVE ROCKER	51	3
[B]		
BAG, TOOL, 160MM	101	10
BAND	103	37
BAND B1, WIRE	87	1
BAND, CORD	85	18
BAND, TUBE CLIP, 11MM	81	20
BAND, TUBE CLIP, 12.5MM	81	19

E-2 CYLINDER HEAD

Block No.

Ref No.

		Reqd. QTY							
Ref. No.	Part No.	9901	9901	1001	1001	1001	1001	1001	1001
1	12166-ZW9-000	STOPPER, ENGINE SIDE	2	2	2	2	2	2	2
2	12210-ZW9-000ZA	HEAD COMP., CYLINDER	1	1	1	1	1	1	1
3	12251-ZW9-003	GASKET, CYLINDER HEAD	1	1	1	1	1	1	1
4	12310-ZW9-000	COVER COMP., HEAD	1	1	1	1	1	1	1
5	12312-ZW9-000	PACKING, HEAD COVER	1	1	1	1	1	1	1
6	15611-921-000	CAP, OIL (NO GAUGE)	1	1	1	1	1	1	1
7	16617-ZW9-000	HOLDER, CABLE	1	1	1	1	1	1	1
	16617-ZW9-010		1	1	1	1	1	1	1
8	35673-ZW5-003	SENSOR ASSY., WATER	1	1	1	1	1	1	1
9	90003-ZW9-000	BOLT, FLANGE, 6X22	4	4	4	4	4	4	4
10	90007-ZW9-003	BOLT, FLANGE, 8X83	6	6	6	6	6	6	6
11	90011-ZW9-000	BOLT, FLANGE, 6X14 (CT200)	1	1	1	1	1	1	1
12	90020-ZW9-000	BOLT, FLANGE, 8X40	2	2	2	2	2	2	2
13	91202-KJ9-003	OIL SEAL, 30X32X6	1	1	1	1	1	1	1
14	91301-805-000	O-RING, 26X2.7	1	1	1	1	1	1	1
15	91307-PK2-005	O-RING, 9.5X1.5 (HONDA KIKAKI)	1	1	1	1	1	1	1
16	98059-55916	PLUG, SPARK (CR5EH-9)	2	2	2	2	2	2	2
	98059-55926	PLUG, SPARK (U16FER9)	2	2	2	2	2	2	2

Page No.

2000.09.20 E

1

2

2019.12.10 E

Part catalogue structure

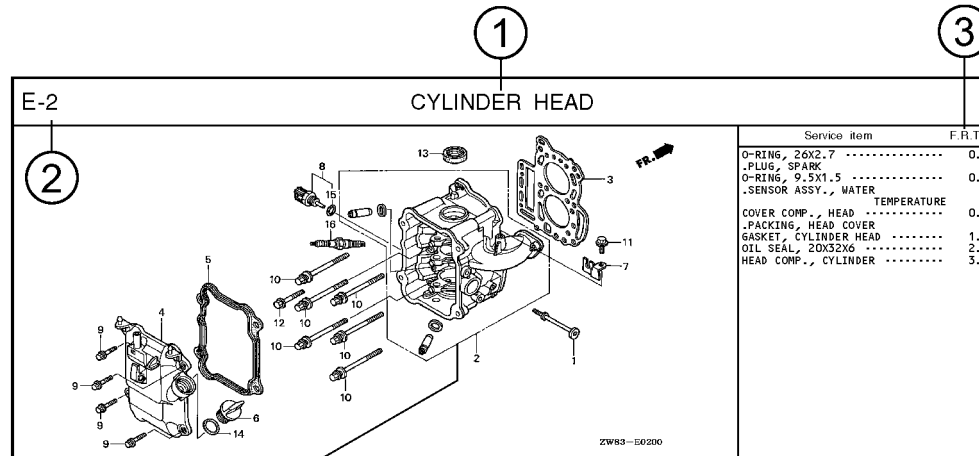

Ref. No.	Part No.	Description	Reqd. QTY						Serial No.	Parts catalogue code
			BF 9.9D1	BFF 9.9D1	BF 10D1	BFF 10D1	BF 10B1	BFF 10B1		
1	12166-zw9-000	STOPPER, ENGINE SIDE	2	2	2	2	2			
2	12210-zw9-000ZA	HEAD COMP., CYLINDER								
		NH8.....DARK GRAY	1	1	1	1	1			
3	12251-zw9-003	GASKET, CYLINDER HEAD	1	1	1	1	1			
4	12310-zw9-000	COVER COMP., HEAD	1	1	1	1	1			
5	12312-zw9-000	PACKING, HEAD COVER	1	1	1	1	1			
6	15611-921-000	CAP, OIL	1	1	1	1	1			
		(NO GAUGE)								
7	16617-zw9-000	HOLDER, CABLE	1	1	1	1	1	----- SC,SG		
	16617-zw9-010		1	1	1	1	1	----- 1001800 LHC,LHD		

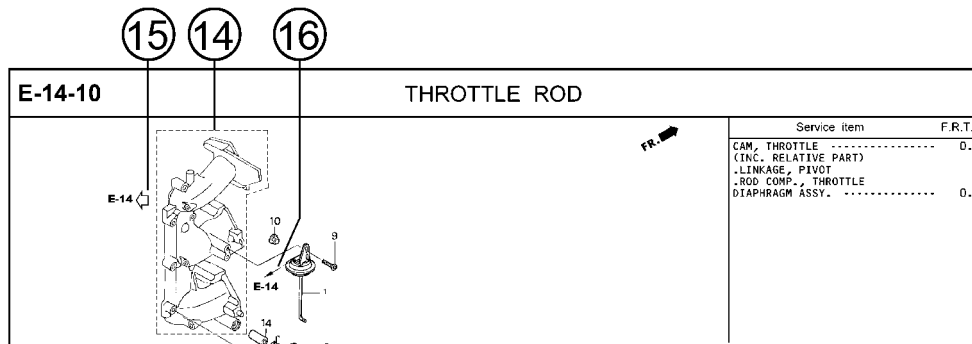

① Block title ② Block number

③ Service item/Flat rate time

④ Reference number

- Title number marked with the parenthesis or parentheses indicates that it continues from the previous page.

⑤ Part number ⑥ Honda color code

⑦ Description

⑧ Assemblies

- Sections framed with broken lines in the exploded view drawings are available as complete assemblies. (Their individual parts can also be obtained.)

⑨ Color description

⑩ Note

- Notes are shown with the parentheses in the part name column.

⑪ Required quantity

- Required QTY shown in the parenthesis or parentheses indicates the optional part.
- Required QTY marked with "N" Indicates the optional part that should be selected as needed.
- Required QTY indicates the number of the part used in the block.

⑫ Serial number

⑬ Type

- When the type column is blank, it indicates that the part is applicable to all types.
- As the type of the actual unit may differ from the "parts catalogue, type" please refer to "Models, types and applicable serial numbers" for confirmation.

⑭

- Parts enclosed within a dotted line are covered in a different block.

⑮

- A hollow arrow indicates the block No. for the parts enclosed within a dotted line.

⑯

- A solid arrow indicates the block No. the part in question is connected to.

When the parts were revised



Be sure to check the serial number!!



Ref. No.	Part No.	Description	Reqd. QTY						Serial No.
			BF 99D1	BFP 99D1	BF 10D1	BFP 10D1	BF 10B1	BFP 10B1	
1	12166-ZW9-000	STOPPER, ENGINE SIDE	2	2	2	2	2	2	
2	12210-ZW9-000ZA	HEAD COMP., CYLINDER *NHS* DARK GRAY	1	1	1	1	1	1	
3	12251-ZW9-003	GASKET, CYLINDER HEAD	1	1	1	1	1	1	
4	12310-ZW9-000	COVER COMP., HEAD	1	1	1	1	1	1	
5	12312-ZW9-000	PACKING, HEAD COVER	1	1	1	1	1	1	
6	15611-921-000	CAP, OIL (NO GAUGE)	1	1	1	1	1	1	
7	16617-ZW9-000	HOLDER, CABLE (###)	1	1	1	1	1	1	SC, SG LHC, LHD 1001800 1001801
	16617-ZW9-010	1	1	1	1	1	1	

The number has been used from the initial model without revision. When shown at the left side it is applicable to the models of No.1001801 and the subsequent numbers. When shown at the right side it is applicable to the models up to No.1001800.

• The parts listed with "###" at the end of the parts name have limited supply period (parts not for sale).

Abbreviations used in the parts catalogue

• The following abbreviations are used in the parts name column.

- A Ampere
- A.C. Alternating current
- ASSY. Assembly
- AT. Automatic transmission
- C.D.I. Capacitive discharge ignition
- COMP. ... Complete
- D.C. Direct current
- EX. Exhaust
- G.F.C.I ... Ground fault circuit interruptor
- HEX. Hexagonal
- H.S.T. Hydrostatic transmission
- FR.Front
- IN.Inlet
- L (100L) .Link (100 Links)
- L.Left
- MMMillimeter
- MT.Manual Transmission
- P.T.O.Power take off
- R.Right
- RR.Rear
- STD.Standard
- T (22T) ...Tooth (22 Teeth)
- V Volt
- WWatt

How to check the part block and serial numbers

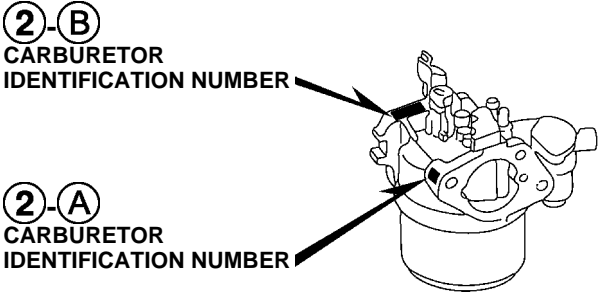
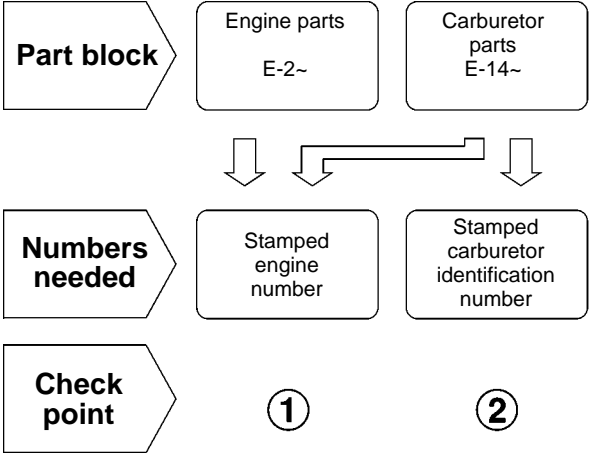

D33Z7E8CA0

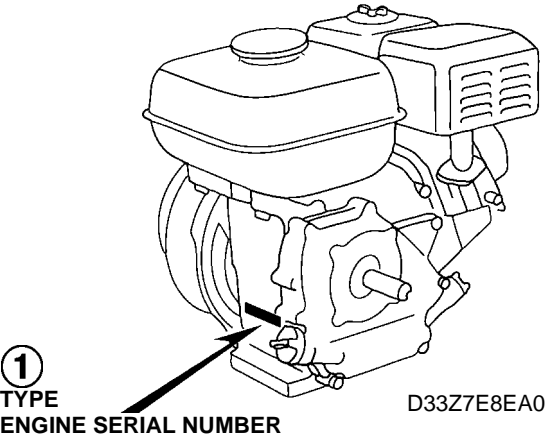

Models, parts catalogue codes and applicable serial numbers

• Models, parts catalogue codes and applicable serial Nos. given in this parts catalogue can be identified as follows.

Model	Type	Parts catalogue type	Applicable engine serial No.	Applicable carburetor identification No.	Model	Type	Parts catalogue type	Applicable engine serial No.	Applicable carburetor identification No.
GX390H1	EDF6	EDF6	GCAFH-0000001~	BE87G B	GX390H1	QA2	QA2	GCAFH-0000001~9999999	BE85T A/B
	EDS1	EDS1		BE88P A					
	EDS2	EDS2		BE85T A/B BEA6C A					
	EDT1	EDT1							
	ES2	ES2		BE89J A					
	ES3S	ES3S	GCAFH-0000001~9999999	BE87A C		QH	QH	GCAFH-0000001~	BE85T A/B
	ES4S	ES4S							
	LH	LH	GCAFH-0000001~	BE85T A/B		QH1	QH1		BE88P A
	LH1	LH1							
	LH2	LH2				GCAFH-0000001~9999999	QHB1	QHB1	GCAFH-0000001~9999999
	LHB5	LHB5							
	LHP1	LHP1	GCAFH-0000001~			QHB3	QHB3	GCAFH-0000001~9999999	BE85T A/B BEA6C A
	LXE9	LXE9				QHB5	QHB5		GCAFH-0000001~
	PX	PX				GCAFH-0000001~	QHBR	QHBR	
			QHE		QHE	GCAFH-0000001~9999999	BE88P A		
					QHP1		QHP1	GCAFH-0000001~9999999	
					QMH	QMH	GCAFH-0000001~9999999		
					QN	QN		GCAFH-0000001~9999999	
					QP	QP	GCAFH-0000001~9999999		

1

Model	Type	Parts catalogue type	Applicable engine serial No.	Applicable carburetor identification No.
GX390H1	QX	QX	GCAFH-0000001~	BE85T A/B
	QXBR	QXBR		BE85T A/B BEA6C A
	QXE	QXE		BE85T A/B
	QXEK	QXEK	GCAFH-0000001~9999999	
	QXHQ	QXHQ	GCAFH-0000001~	
	QXK	QXK	GCAFH-0000001~9999999	
	SH	SH	GCAFH-0000001~	
	SH1	SH1		
	SHE	SHE		
	SM11	SM11	GCAFH-0000001~9999999	BE88P A
	SWE2	SWE2		
	SWX2	SWX2	GCAFH-0000001~	BE85T A/B
	SX	SX		
SX1	SX1			

Model	Type	Parts catalogue type	Applicable engine serial No.	Applicable carburetor identification No.
GX390H1	SXC	SXC	GCAFH-0000001~	BE85T A/B
	SXC1	SXC1		
	SXE	SXE	GCAFH-0000001~9999999	
	SXE1	SXE1		
	VMQ3	VMQ3		
	VMT3	VMT3		
	VPKK	VPKK	GCAFH-0000001~	BE89L C
	VPX4	VPX4	GCAFH-0000001~9999999	
	VPXB	VPXB	GCAFH-0000001~	
	VPXE	VPXE	GCAFH-0000001~9999999	
	VPXJ	VPXJ		
	VPXK	VPXK	GCAFH-0000001~	
	VPXX	VPXX	GCAFH-0000001~9999999	BE89J A
	VS4	VS4		

Model	Type	Parts catalogue type	Applicable engine serial No.	Applicable carburetor identification No.
GX390H1	VS6	VS6	GCAFH-0000001~9999999	BE89J A
	VSB4	VSB4		BE89K A
	VSP	VSP	GCAFH-0000001~	BE85L A BE85U A
	VTE5	VTE5		BE88P A
	VX	VX		BE85U A BE88Q A
	VX1	VX1		BE88Q A
	VX1M	VX1M		BE85U A BE88Q A
	VXE	VXE		BE89J A
	VXEK	VXEK		BE88Q A
	VXEM	VXEM	GCAFH-0000001~9999999	BE85U A BE88Q A
	VXK	VXK	GCAFH-0000001~	BE89J A
	VXKS	VXKS	GCAFH-0000001~	BE85U A BE88Q A
	VXU1	VXU1	GCAFH-0000001~9999999	BE85U A BE88Q A

Model	Type	Parts catalogue type	Applicable engine serial No.	Applicable carburetor identification No.
GX390H2	EDS1	EDS1	GCBBH-1000001~	BE96E A
	EDS2	EDS2		
	EDT1	EDT1		
	ES2	ES2		BE96F A
	LH	LH		BEA6J A
	LH1	LH1		
	PX	PX		
	QH	QH		
	QH1	QH1		
	QHE	QHE		
	QMH	QMH		
	QN	QN		
	QX	QX		
	QXE	QXE		

Model	Type	Parts catalogue type	Applicable engine serial No.	Applicable carburetor identification No.	
GX390H2	QXHQ	QXHQ	GCBBH-1000001~	BEA6J A	
	SH	SH			
	SH1	SH1			
	SHE	SHE			
	SM11	SM11			
	SWX2	SWX2			
	SX	SX			
	SX1	SX1			
	SXC	SXC			
	SXC1	SXC1			
	VPKK	VPKK			BE96D A
	VPXB	VPXB			
	VPXE	VPXE			
	VPXK	VPXK			

Model	Type	Parts catalogue type	Applicable engine serial No.	Applicable carburetor identification No.
GX390H2	VPXX	VPXX	GCBBH-1000001~	BE96D A
	VTE5	VTE5		BEA6J A
	VX	VX		
	VX1	VX1		
	VX1M	VX1M		
	VXE	VXE		BE96F A
	VXEK	VXEK		
	VXEM	VXEM		
	VXKS	VXKS		BEA6J A
				BE96F A

* Of carburetor identification numbers, only the portions underlined in the example below are used for registration.

BE 87G A KC ナ
 (A) (B)

Features of each type

• See the following table for the features of each type. (Items in brackets are optional)

Specifications		Model	GX390H1													
		Type	EDF6	EDS1	EDS2	EDT1	ES2	ES3S	ES4S	LH	LH1	LH2	LHB5	LHP1	LXE9	PX
Crankshaft	25mm Ø X 117mm Straight															
	25.4mm Ø X 142.5mm Straight															
	5/16" Tapered						●	●								
	35mm Ø Tapered	●	●	●	●	●										
	30mm Ø Spline								●	●	●	●	●	●		
	25.4mm Ø Spline															●
Oil alert			●	●	●	●	●	●	●						●	●
Oil level switch			●	●	●	●	●	●	●						●	●
Charge coil			●	●	●				●						●	
Starter motor			●	●	●				●						●	
Control box															●	
Reduction										●	●	●	●	●	●	

1

Specifications		Model	GX390H1													
		Type	QA2	QBE1	QEBR	QH	QH1	QHB1	QHB3	QHB5	QHBR	QHE	QHP1	QMH	QN	QP
Crankshaft	25mm Ø X 117mm Straight															
	25.4mm Ø X 142.5mm Straight	●	●	●	●	●	●	●	●	●	●	●	●	●	●	●
	5/16" Tapered															
	35mm Ø Tapered															
	30mm Ø Spline															
	25.4mm Ø Spline															
Oil alert		●		●												
Oil level switch		●		●												
Charge coil			●	●							●					
Starter motor			●	●							●					
Control box			●	●							●					
Reduction																

1

Specifications		Model	GX390H1													
		Type	QX	QXBR	QXE	QXEK	QXHQ	QXK	SH	SH1	SHE	SM11	SWE2	SWX2	SX	SX1
Crankshaft	25mm Ø X 117mm Straight								●	●	●	●	●	●	●	●
	25.4mm Ø X 142.5mm Straight	●	●	●	●	●	●									
	5/16" Tapered															
	35mm Ø Tapered															
	30mm Ø Spline															
	25.4mm Ø Spline															
Oil alert		●	●	●	●	●	●						●	●	●	
Oil level switch		●	●	●	●	●	●						●	●	●	
Charge coil				●	●					●		●				
Starter motor				●	●					●		●				
Control box				●	●					●		●				
Reduction																

Specifications		Model	GX390H1													
		Type	SXC	SXC1	SXE	SXE1	VMQ3	VMT3	VPKK	VPX4	VPXB	VPXE	VPXJ	VPXK	VPXX	VS4
Crankshaft	25mm Ø X 117mm Straight	●	●	●	●											
	25.4mm Ø X 142.5mm Straight															
	5/16" Tapered					●		●	●	●	●	●	●	●	●	●
	35mm Ø Tapered						●									
	30mm Ø Spline															
	25.4mm Ø Spline															
Oil alert		●	●	●	●	●	●	●	●	●	●	●	●	●	●	●
Oil level switch		●	●	●	●	●	●	●	●	●	●	●	●	●	●	●
Charge coil				●	●		●	●			●	●	●	●		
Starter motor				●	●		●	●			●	●	●	●		
Control box				●	●		●									
Reduction																

Specifications		Model	GX390H1												
		Type	VS6	VSB4	VSP	VTE5	VX	VX1	VX1M	VXE	VXEK	VXEM	VXK	VXKS	VXU1
Crankshaft	25mm Ø X 117mm Straight														
	25.4mm Ø X 142.5mm Straight														
	5/16" Tapered	●	●	●	●	●	●	●	●	●	●	●	●	●	
	35mm Ø Tapered														
	30mm Ø Spline														
	25.4mm Ø Spline														
Oil alert		●	●	●	●	●	●	●	●	●	●	●	●	●	
Oil level switch		●	●	●	●	●	●	●	●	●	●	●	●	●	
Charge coil		●			●				●	●	●	●		●	
Starter motor		●			●				●	●	●	●		●	
Control box					●				●		●	●		●	
Reduction															

Specifications		Model	GX390H2													
		Type	EDS1	EDS2	EDT1	ES2	LH	LH1	PX	QH	QH1	QHE	QMH	QN	QX	QXE
Crankshaft	25mm Ø X 117mm Straight															
	25.4mm Ø X 142.5mm Straight									●	●	●	●	●	●	●
	5/16" Tapered															
	35mm Ø Tapered	●	●	●	●											
	30mm Ø Spline					●	●									
	25.4mm Ø Spline								●							
Oil alert																
Oil level switch		●	●	●	●				●						●	●
Charge coil		●	●									●				●
Starter motor		●	●									●				●
Control box												●				●
Reduction						●	●									

Specifications		Model	GX390H2												
		Type	QXHQ	SH	SH1	SHE	SM11	SWX2	SX	SX1	SXC	SXC1	VPKK	VPXB	VPXE
Crankshaft	25mm Ø X 117mm Straight		●	●	●	●	●	●	●	●	●				
	25.4mm Ø X 142.5mm Straight	●													
	5/16" Tapered											●	●	●	●
	35mm Ø Tapered														
	30mm Ø Spline														
	25.4mm Ø Spline														
Oil alert															
Oil level switch		●					●	●	●	●	●	●	●	●	●
Charge coil					●							●		●	●
Starter motor					●							●		●	●
Control box					●										
Reduction															

Specifications		Model	GX390H2								
		Type	VPXX	VTE5	VX	VX1	VX1M	VXE	VXEK	VXEM	VXKS
Crankshaft	25mm Ø X 117mm Straight										
	25.4mm Ø X 142.5mm Straight										
	5/16" Tapered	●	●	●	●	●	●	●	●	●	
	35mm Ø Tapered										
	30mm Ø Spline										
	25.4mm Ø Spline										
Oil alert											
Oil level switch		●	●	●	●	●	●	●	●	●	
Charge coil		●	●				●	●	●		
Starter motor		●	●				●	●	●		
Control box			●				●		●		
Reduction											

Fuel hose, general purpose hoses and vinyl hose

- The standard part fuel hose, general purpose hose and vinyl hose may be substituted by the coiled bulk part.
- When ordering the standard part fuel hose, general purpose hose and vinyl hose use the bulk part number written in the parts catalog in brackets () underneath the part name.
- When exchanging the hose, cut and use at the specified length as mentioned in the part name.
(For the method of cutting the bulk part, and method of filling out orders etc., please refer to the instructions issued with the bulk part.)

Bulk part number of fuel hose, general purpose hose and vinyl hose.

Example: 9 5 0 0 1 - 7 5 0 0 1 - 5 0 M

Bulk part number:

Refers to the bulk part.

Marking code (fuel hose and general purpose hose)

Change code (Vinyl hose)

Indicates number mark or change sequence, however, the code for the bulk part must be strictly 0 (zero).

Types of code:

- | | | | | | |
|-------------|--------------------------------------------------------|----------------|-------------|--------------|---------------|
| • Fuel hose | 2: Red outside braid
(3 mm inside dia. only) | • General hose | 1: Ash gray | • Vinyl hose | 1: Clear |
| | 5: Black inside braid | | 2: Ash gray | | 2: Black |
| | 3: Red (3 mm inside dia. only) | | 3: Black | | 3: Light red |
| | 4: Ash gray with red stripe
(3 mm inside dia. only) | | 5: Black | | 6: Light red |
| | 6: Black | | | | 7: Pale black |

Lengths:

- 001: 1 m (standard)
003: 3 m
008: 8 m } Application or specification of some parts is not settled.

I.D code: (fuel hose and general purpose hose)

- | | | | | |
|------------|--------------------|--------------------|-----------------------------|-----------------------------|
| 30: 3.0 mm | 50: 5.0 mm | 70: 7.0 mm | 11: 11 mm | 12: 12 (outside dia. 17) mm |
| 35: 3.5 mm | 55: 5.3 mm, 5.5 mm | 75: 7.3 mm, 7.5 mm | 91: 12 (outside dia. 15) mm | 14: 14 mm |
| 45: 4.5 mm | 65: 6.5 mm | 80: 8.0 mm | 92: 12 (outside dia. 16) mm | 17: 17 mm |

ID./OD. code: (vinyl hose)

- | | | | | |
|-------------------------|--------------------------|---------------------------|---------------------------|---------------------------|
| 01: ID. 2.9, OD. 6.8 mm | 12: ID. 5.0, OD. 7.0 mm | 21: ID. 8.0, OD. 9.0 mm | 37: ID. 11.0, OD. 15.0 mm | 50: ID. 16.0, OD. 19.0 mm |
| 03: ID. 3.0, OD. 6.0 mm | 10: ID. 5.0, OD. 8.0 mm | 23: ID. 8.0, OD. 12.0 mm | 38: ID. 12.0, OD. 13.0 mm | 55: ID. 17.5, OD. 20.5 mm |
| 05: ID. 3.5, OD. 6.5 mm | 11: ID. 5.0, OD. 9.0 mm | 25: ID. 9.0, OD. 11.0 mm | 39: ID. 12.0, OD. 14.0 mm | 60: ID. 22.0, OD. 27.0 mm |
| 07: ID. 4.0, OD. 7.0 mm | 14: ID. 6.0, OD. 9.0 mm | 27: ID. 9.0, OD. 13.0 mm | 40: ID. 12.0, OD. 16.0 mm | |
| 08: ID. 4.5, OD. 6.5 mm | 17: ID. 7.0, OD. 9.0 mm | 33: ID. 10.0, OD. 14.0 mm | 43: ID. 13.0, OD. 15.0 mm | |
| 09: ID. 4.5, OD. 8.0 mm | 19: ID. 7.0, OD. 11.0 mm | 36: ID. 11.0, OD. 13.0 mm | 45: ID. 14.0, OD. 18.0 mm | |

Hose type:

- 1: Fuel hose
3: Vinyl hose
5: General hose

⊙ **CAUTION: It is DANGEROUS to confuse the fuel hose with the general purpose hose or vinyl hose.**

Never use a general purpose hose or vinyl hose in place of a fuel hose or vice versa. Always use the correct bulk part in the parts catalogue, according to the service manual or the instructions issued with the bulk part.

FLAT RATE SERVICE TIME

Flat rate service time (FRT) means the standard time required to service a product, which is listed in this manual to help the dealers control the actual working process and calculate the service charge by using it as a guide.

FRT setting system

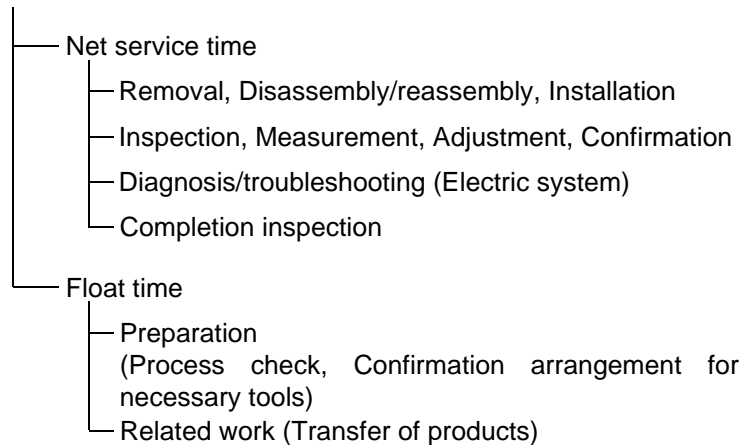

* Float time is set by multiplying the net service time by a given coefficient.

Editorial style

The service items shown in the text are listed with the exchange work time for the repair sales parts as the subject. Other representative service items not using repair parts (removal/installation, adjustment, inspection/measuring, and other work) are listed collectively in the list in the preface, classified according to the work.

FRT setting standard

- Decimal system (in unit of 0.1) is adopted to set FRT as it is convenient to calculate the wage.
Example: (0.1) → 6 minutes, (0.2) → 12 minutes
[Labor cost per hour] x [FRT] = [Wage]
- FRT is set with a hand tool.
- Service items and FRT can be subject to change depending on development of tools and service equipment and improvement in service procedure.

Work procedure

- As the work procedure is set with the work time according to the method in the separate Service Manual, refer to this Manual as required.
- Work methods permitting servicing in the shortest time still permitting assurance of safe work and product warranty are used for the setting of service items not listed in the Service Manual.
- Work basically is to be performed by one person, and when two or more people are required, setting is done as the total time for the number of people.
- The set value for the technological level of the workers uses a person with three years of experience in the repair of Honda products as the standard.
- Special tools and service equipment used to set FRT are those specified or recommended in Service Manual.

Service item whose FRT is not presented

- Accessories and service parts that are not listed to use in this manual.
 - Locations with little aging deterioration or breakage during normal use.
 - Service work that can be finished by one touch.
 - Service work that is seldom done (i.e. extremely small causes of trouble and service frequency).
 - Products and parts whose location for installation differs according to its status of use and application.
- * When FRT is not presented, please calculate wages based on appropriate actual work time.

Operation not included of FRT

- Oil and coolant water draining, Waiting time for warming up operation and etc..
- Additional operation that involves removal/installation of standard exterior equipment.
- Indirect time spent for service by visiting the customer, trade-in, and delivery.
- Indirect time required for ordering and delivery of parts.
- Cost for grease, adhesive agent, etc. used for service work.

**Explanation of FRT by using an example
(The example may differ from the actual presented items)**

Ref. No.	L.O.N.	(Relative ref. Number) Description	F.R.T.
①	1111L1	④ (1, 3, 4, 7) VALVE, INTAKE4.1	②
②		• NOTE: OHV type ⑥	⑦
③	1111L1A	• Includes: Engine removal and installation One head (intake all) add1.4 ⑤	

- ① Reference No. of the illustration of part that shows location of the replacement work.
- ② FRT is an abbreviation of Flat Rate Time indicating the standard service time required for the replacement.
- ③ LON is an abbreviation of Labor Operation Number, and it is a classification of the service items by the work unit code.

The same operation code is used regardless of the models.

Standard operation is indicated with 6 digits code, and additional operation is indicated with 7 digits code.

- ④ Indicating the intake valve replacement and FRT4.1.
- ⑤ Indicating FRT1.4 that will be added when additional operation (whole intake side of one cylinder head) is done in association with intake valve replacement.

- ⑥ Indicating work condition or application condition of the service item.
- ⑦ Indicating work contents that are included in the service item.
- ⑧ Indicating a reference No. whose operation and time are the same as FRT4.1 for the intake valve.

(The application range is limited to the service items without an LON setting within a same block.)

**How to refer to the service item by using the sample
(intake valve replacement)**

Open to the page of the block where the intake valve's spare part illustration is shown.



Look for the intake valve illustration, and refer to the service item and FRT that agree with the reference No.

Indication mark for the listing of service items that continues to the following page

Ref. No.	L.O.N.	(Relative ref. Number) Description	F.R.T.
2	1111L1	VALVE, INTAKE	4.1
	.	.	.
	.	.	.

+
Mark indicated at the last line.

Indication of the block with no setting of FRT

Ref. No.	L.O.N.	(Relative ref. Number) Description	F.R.T.
NO INFORMATION			

• LON code system

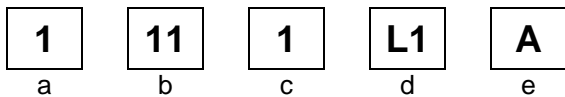

- a) Category code..... Engine
- b) Location/function code..... Engine upper
- c) Operation code..... Replace
- d) Operation sequence number (Unit code can be shown with alphabet)
..... Intake valve
(No regular rule of code)
- e) Additional code One head (intake all)
(No regular rule of code)

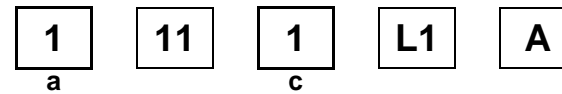

a) Category codes and classification

Code	Category
1	Engine
2	Power drive
3	Fuel & Exhaust
4	Frame & Body
5	Steering
6	Electrical
7	Axle & Brake
8	Control system
9	-
0	Attachments

c) Operation codes and classification

Code	Operation category
1	Replace, Removal/Installation, Change
2	Overhaul
3	Adjust, Rotation
4	(Paint-related work: Top-coat)
5	Test, Inspect/diagnose, Measurement
6	(Overhaul-related work: Rebore)
7	(Overhaul-related work: Reseal)
8	(Resurface)
9	(Paint-related work: Refinish)
0	Repair, Cleaning, Air bleeding

Major service items without using spare parts
 Adjustment, Inspection/Measurement, Overhaul, Other work

E: Engine, T: Transmission, D: Drive system, B: Body and related parts

• **Adjustment**

	LON	DESCRIPTION	FRT
E	1113A1	VALVE CLEARANCE-ADJUSTMENT NOTE: For 1 product	0.3
	1163A0	CONTROL, THROTTLE/GOVERNOR-ADJUSTMENT	0.2
	3113A2	CARBURETOR IDLE-ADJUSTMENT	0.2

• **Inspection/Measurement**

	LON	DESCRIPTION	FRT
E	1105A0	ENGINE OIL-INSPECTION	0.1

• **Overhaul**

Work condition: The required Measurements, inspections, adjustments, and cleaning/washing of each part are performed, including the main body removal/installation work and the replacement of defective parts.

	LON	DESCRIPTION	FRT
E	3112A0	CARBURETOR-OVERHAUL INCLUDES: All necessary adjustment	0.6

• **Other work**

	LON	DESCRIPTION	FRT
E	1101E1	ENGINE OIL-CHANGE INCLUDES: Engine oil-inspection	0.2
	3120A0	AIR CLEANER-CLEANING INCLUDES: Air cleaner-inspection	0.2
	3130A0	SPARK ARRESTER-CLEANING INCLUDES: Spark arrester-inspection	0.2
	6140A0	SPARK PLUG-ADJUSTMENT/CLEANING INCLUDES: Spark plug check NOTE: For 1 product	0.1

ENGINE GROUP

E-2

CYLINDER HEAD

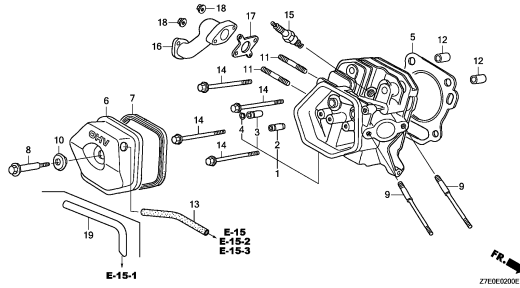

Z710E000E

E-3

CYLINDER BARREL

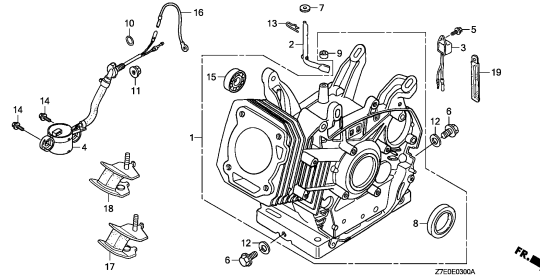

Z710E000A

E-6

CRANKCASE COVER(1)

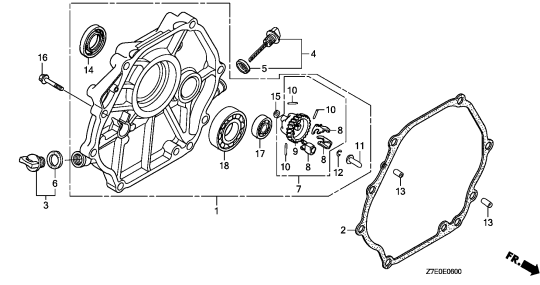

Z710E000D

E-6-1

CRANKCASE COVER(2)

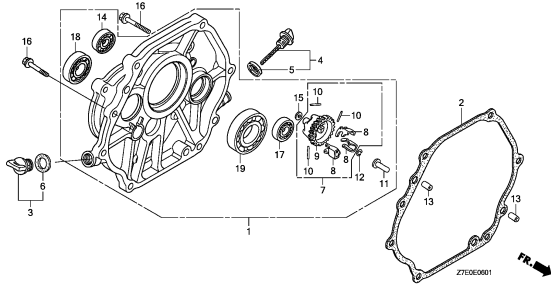

Z710E000I

E-6-2

CRANKCASE COVER(3)

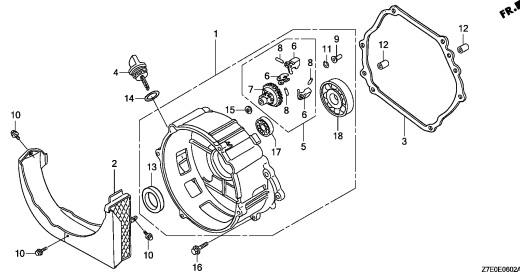

Z710E000A

E-7

CRANKSHAFT

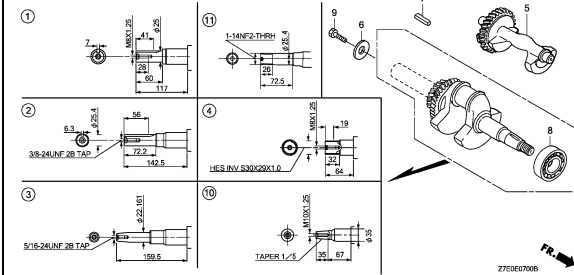

Z710E000B

E-8

PISTON

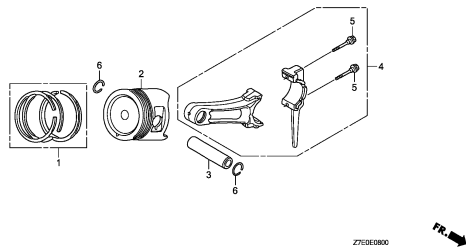

Z710E000C

E-9

CAMSHAFT

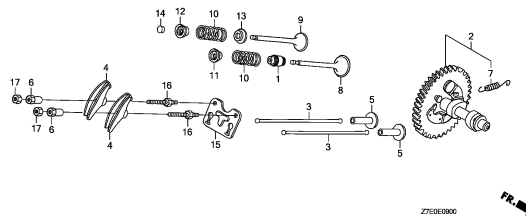

Z710E0000

E-11

RECOIL STARTER(1)

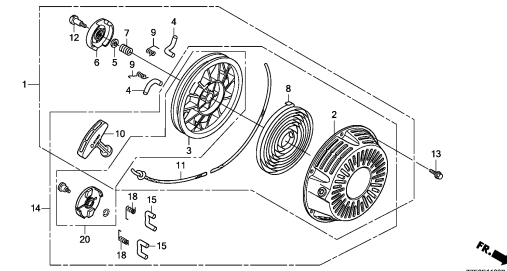

Z710E1100B

ENGINE GROUP

E-11-1

RECOIL STARTER(2)

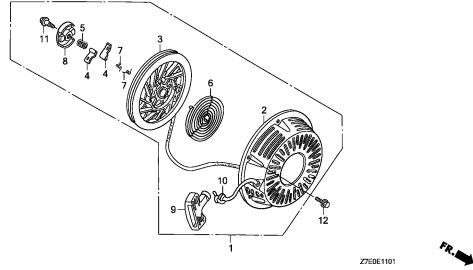

E-11-2

RECOIL STARTER(3)

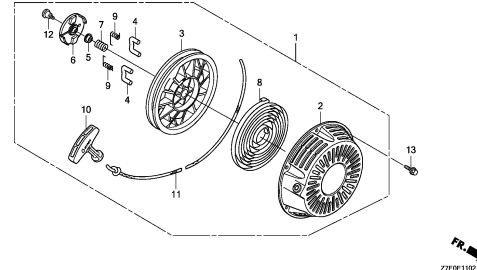

E-12

FAN COVER

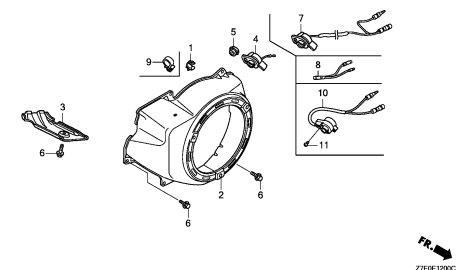

E-14

CARBURETOR(1)

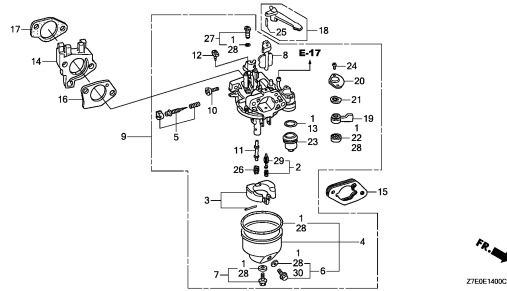

E-14-1

CARBURETOR(2)

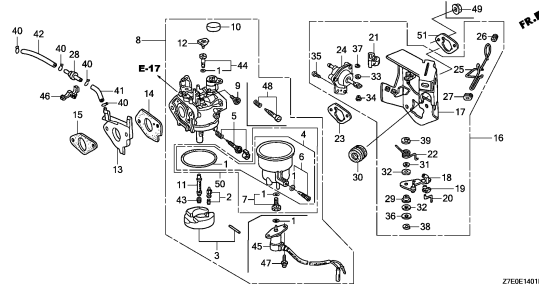

E-15

AIR CLEANER(1)

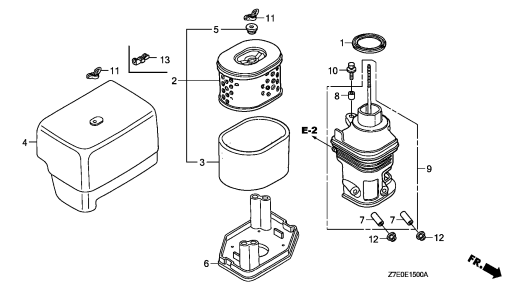

E-15-1

AIR CLEANER(2)

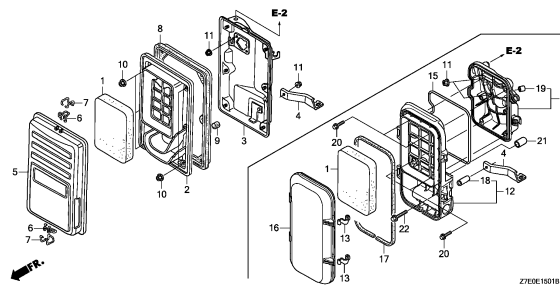

E-15-2

AIR CLEANER(3)

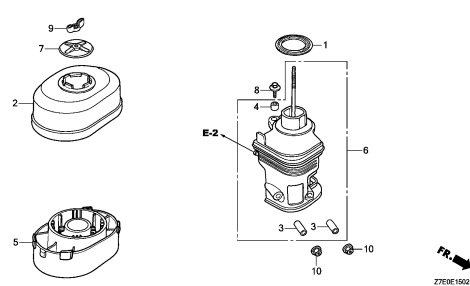

E-15-3

AIR CLEANER(4)

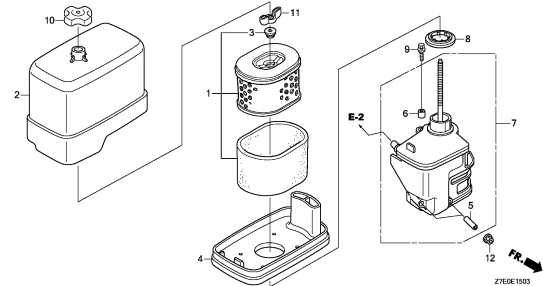

2

ENGINE GROUP

E-16

MUFFLER

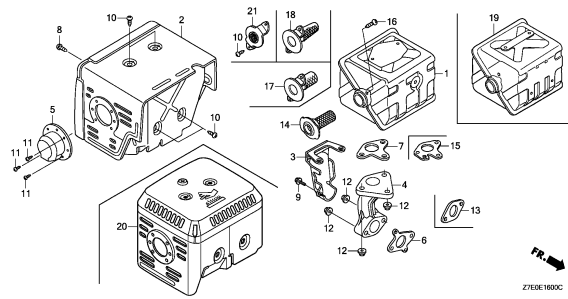

E-17

FUEL TANK

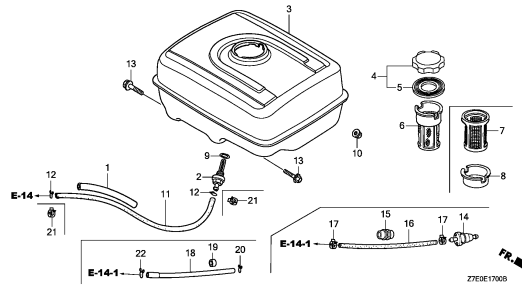

E-19

FLYWHEEL

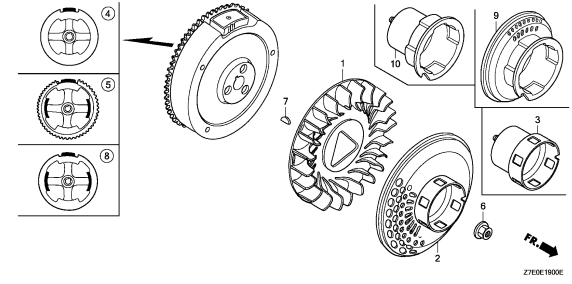

E-20

IGNITION COIL

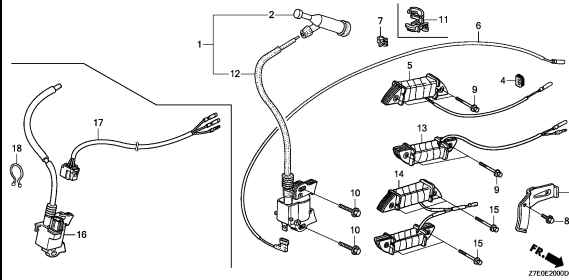

E-21

STARTER MOTOR(1)

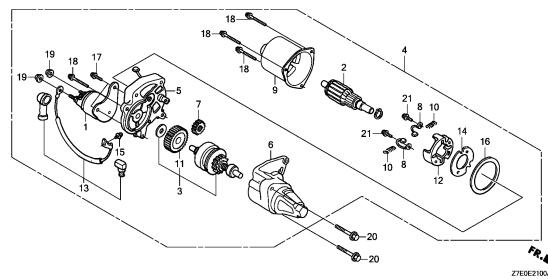

E-21-1

STARTER MOTOR(2)

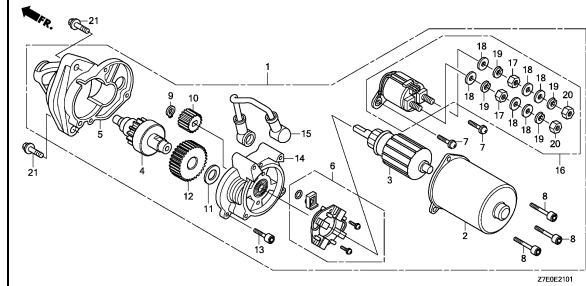

E-22

CONTROL

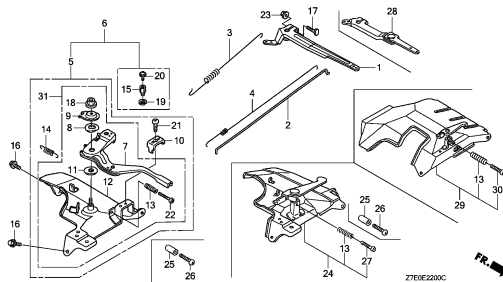

E-22-20

AUTO THROTTLE

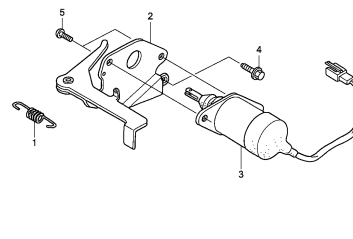

E-23

CONTROL BOX

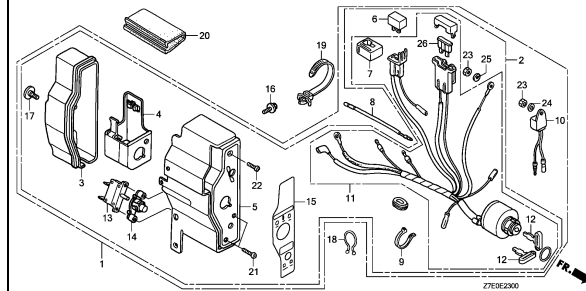

ENGINE GROUP

E-26

REDUCTION(1/2)

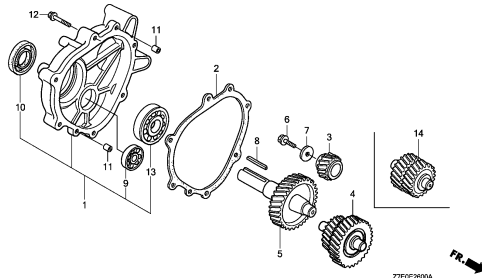

Z7E0E280A

E-28

LABEL

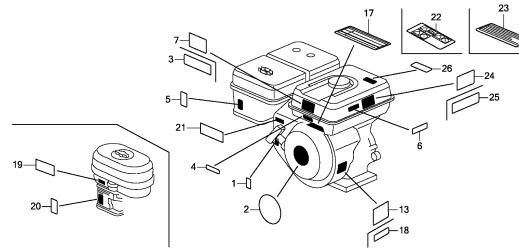

Z7E0E280L

E-29

TOOL

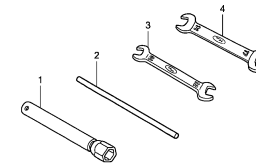

Z7E0E290A

E-40

FUEL COCK/COMBINATION SWITCH

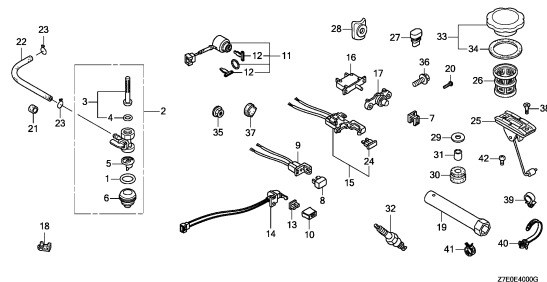

Z7E0E400G

E-40-1

MUFFLER

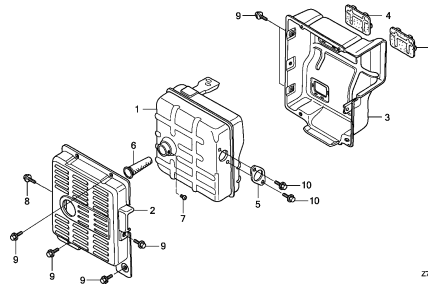

Z7E0E4001

E-40-2

BATTERY TRAY

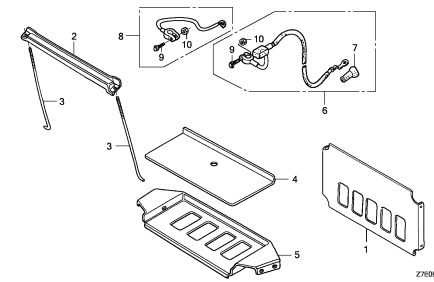

Z7E0E4002

E-40-3

AIR CLEANER

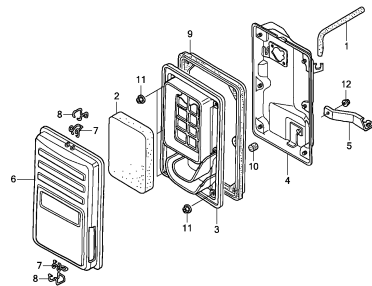

Z7E0E4003

E-40-4

MARK

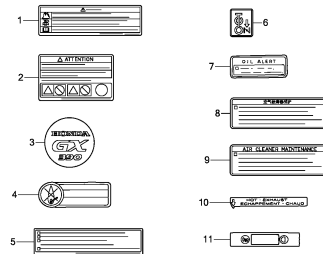

Z7E0E4004

EOP-2

MUFFLER COVER

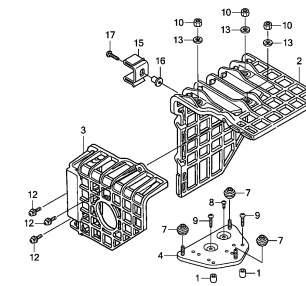

Z7E0E0200B

2

E-2

CYLINDER HEAD

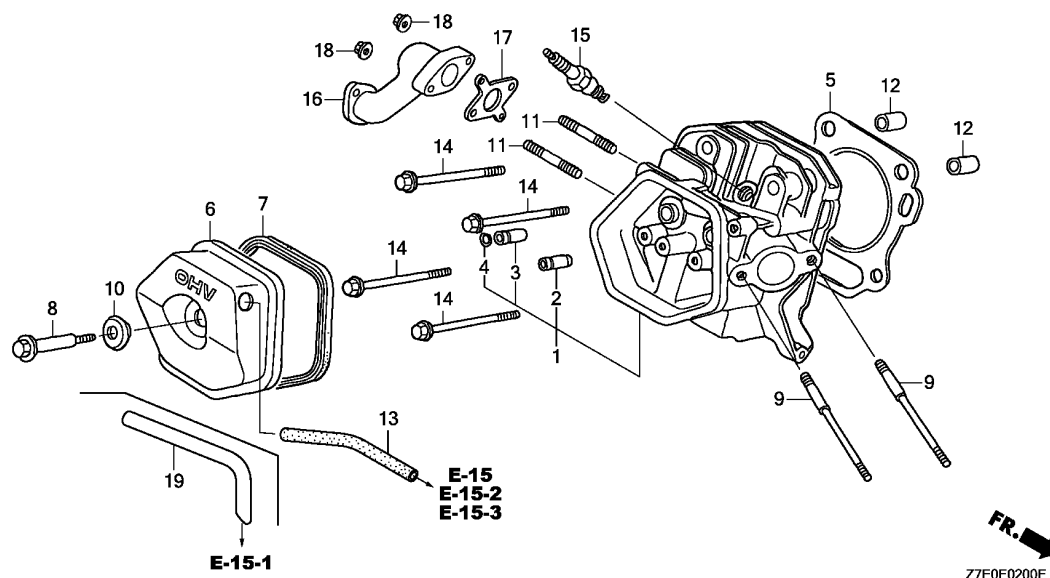

Ref. No.	L.O.N.	(Relative ref. Number) Description	F.R.T.
1	1111N3	HEAD, CYLINDER	0.9
2	1111E9	GUIDE, INTAKE VALVE	0.8
		.INCLUDES: Valve clearance adjustment	
	1111E9E	.Replace intake and exhaust all add	0.2
3	1111E8	GUIDE, EXHAUST VALVE	0.8
		.INCLUDES: Valve clearance adjustment	
	1111E8E	.Replace intake and exhaust all add	0.2
5	1111N4	GASKET, CYLINDER HEAD	0.5
6		(7)	
	1111D5	CYLINDER HEAD COVER AND/OR PACKING	0.1
13		(19)	
	1111K5	TUBE, BREATHER	0.1
15	6141C1	PLUG, SPARK	0.1
		.INCLUDES: Spark plug check	
16	3131C9	PIPE, EXHAUST	0.2
17	3131B5	GASKET, EXHAUST PIPE	0.2

Z7E0E0200E

Ref. No.	Part No.	Description	Reqd. QTY		Serial No.	Parts catalogue code
			GX 390 H1	GX 390 H2		
1	12200-Z7E-000	HEAD COMP., CYLINDER	1	-	-----	EDF6,EDS2,ES2,ES3S,ES4S,LH,LH1,LH2,LHB5,LHP1,LXE9,PX,QA2,QBE1,QEBR,QH1,QHB1,QHB3,QHB5,QHBR,QHE,QHP1,QMH,QN,QP,QX,QXBR,QXE,QXEK,QXHQ,QXK SH,SH1,SHE,SM11,SWE2,SWX2,SX,SX1,SXC,SXC1,SXE,SXE1,VMQ3,VMT3,VPKK VPXE,VPXJ,VPXK,VPXX,VS4,VS6,VS6,VS4,VTE5,VX,VX1,VX1M,VXE,VXEK,VXEM,VXK VXKS,VXU1
	12200-ZF6-406	1	-	-----	EDS1,EDT1,VPX4,VPXB
	12200-Z1C-406	1	-	0001148	VSP
	12200-ZF6-406	1	-	0001149	VSP
	12210-Z7E-405	-	1	-----	
2	12204-ZE2-306	GUIDE, IN. VALVE(O.S.)	1	-	-----	EDF6,EDS1,EDS2,EDT1,ES3S,ES4S,LH,QA2,QH,QHE,QXHQ,SH,SHE,SM11,SX,SXC SXE,VPKK,VPX4,VPXB,VPXE,VPXJ,VPXK,VPXX,VSP,VX,VXEK,VXKS
	12204-Z7E-305	1	-	-----	ES2,LH1,LH2,LHB5,LHP1,LXE9,PX,QBE1,QEBR,QH1,QHB1,QHB3,QHB5,QHBR,QHP1 QMH,QN,QP,QX,QXBR,QXE,QXEK,QXK,SH1,SWE2,SWX2,SX1,SXC1,SXE1,VMQ3,VMT3 VS4,VS6,VS6,VS4,VTE5,VX1,VX1M,VXE,VXEM,VXK,VXU1
	12204-ZE2-306	-	1	-----	
3	12205-ZE2-305	GUIDE, EX. VALVE(O.S.)	1	-	-----	EDF6,EDS1,EDS2,EDT1,ES3S,ES4S,LH,QA2,QH,QHE,QXHQ,SH,SHE,SM11,SX,SXC SXE,VPKK,VPX4,VPXB,VPXE,VPXJ,VPXK,VPXX,VSP,VX,VXEK,VXKS
	12205-Z7E-305	1	-	-----	ES2,LH1,LH2,LHB5,LHP1,LXE9,PX,QBE1,QEBR,QH1,QHB1,QHB3,QHB5,QHBR,QHP1 QMH,QN,QP,QX,QXBR,QXE,QXEK,QXK,SH1,SWE2,SWX2,SX1,SXC1,SXE1,VMQ3,VMT3 VS4,VS6,VS6,VS4,VTE5,VX1,VX1M,VXE,VXEM,VXK,VXU1
	12205-ZE2-305	-	1	-----	
4	12216-ZE2-300	CLIP, VALVE GUIDE	1	1	-----	
5	12251-ZF6-W01	GASKET, CYLINDER HEAD	1	-	-----	EDF6,EDS2,ES2,LH1,LH2,LHB5,LHP1,LXE9,PX,QBE1,QEBR,QH1,QHB1,QHB3,QHB5 QHBR,QHE,QHP1,QMH,QN,QP,QX,QXBR,QXE,QXEK,QXK,SH1,SWE2,SWX2,SX1,SXC1 SXE1,VMQ3,VMT3,VPKK,VPXE,VPXJ,VPXK,VPXX,VS4,VS6,VS6,VS4,VTE5,VX1,VX1M VXE,VXEK,VXEM,VXK,VXKS,VXU1
	12251-ZF6-W00	1	-	-----	EDS1,EDT1,ES3S,ES4S,LH,QA2,QH,QXHQ,SH,SHE,SM11,SX,SXC,SXE,VPX4,VPXB VX

E-2

CYLINDER HEAD

Ref. No.	Part No.	Description	Reqd. QTY		Serial No.	Parts catalogue code
			GX 390 H1	GX 390 H2		
(5)	12251-Z1C-801	GASKET, CYLINDER HEAD (THAI LEAKLESS)	1	-	0001148	VSP
	12251-ZF6-W00	GASKET, CYLINDER HEAD	1	-	0001149	VSP
	12251-Z5T-003	GASKET, CYLINDER HEAD (NIPPON LEAKLESS)	-	1		
6	12310-ZE2-020	COVER COMP., HEAD	1	1		
7	12391-ZE2-020	PACKING, HEAD COVER	1	1		
8	90014-ZE2-000	BOLT, HEAD COVER	1	1		
9	90042-ZE8-000	BOLT, STUD, 8X131.5	2	2		LH, LH1, LH2, LHB5, LHP1, LXE9, PX, QA2, QBE1, QEBR, QH, QH1, QHB1, QHB3, QHB5, QHBR, QHE, QHP1, QMH, QN, QP, QX, QXBR, QXE, QXEK, QXHQ, QXK, SH, SH1, SHE, SM11, SWE2, SWX2, SX, SX1, SXC, SXC1, SXE, SXE1, VSP, VTE5, VX, VX1, VX1M, VXE, VXEK, VXK, VXU1
	90042-ZE3-700	BOLT, STUD, 8X106	2	-		EDF6, EDS1, EDS2, EDT1, ES2, ES3S, ES4S, VMQ3, VMT3, VPKK, VPX4, VPXB, VPXE, VPXJ, VPXK, VPXX, VS4, VS6, VSB4, VXEK, VXKS
	90042-ZK6-D70	BOLT, STUD, 8X115	-	2		EDS1, EDS2, EDT1, ES2, VPKK, VPXB, VPXE, VPXK, VPXX, VXEK, VXKS
10	90441-ZE2-010	WASHER COMP., HEAD COVER	1	1		
11	92900-08032-0E	BOLT, STUD, 8X32	2	2		EDF6, EDS1, EDS2, EDT1, ES2, ES3S, ES4S, LH, LH1, LH2, LHB5, LHP1, LXE9, PX, QA2, QBE1, QEBR, QH, QH1, QHB1, QHB3, QHB5, QHBR, QHE, QHP1, QMH, QN, QP, QX, QXBR, QXE, QXEK, QXHQ, QXK, SH, SH1, SHE, SM11, SWE2, SWX2, SX, SX1, SXC, SXC1, SXE, SXE1, VMQ3, VMT3, VPX4, VPXB, VPXE, VPXJ, VPXK, VS4, VS6, VSB4, VSP, VTE5, VX, VX1, VX1M, VXE, VXEM, VXK, VXU1
	92900-08022-0E	BOLT, STUD, 8X22	2	2		VPKK, VPXX
12	94301-12200	DOWEL PIN, 12X20	2	2		
13	95005-11105-30	TUBE, 11X105(95005-11001-30M)	1	-		LH, LH1, LH2, LHB5, LHP1, LXE9, PX, QA2, QBE1, QEBR, QH, QH1, QHB1, QHB3, QHB5, QHBR, QHE, QHP1, QMH, QN, QP, QX, QXBR, QXE, QXEK, QXHQ, QXK, SH, SH1, SHE, SM11, SWE2, SWX2, SX, SX1, SXC, SXC1, SXE, SXE1, VSP, VTE5, VX, VX1, VX1M, VXE, VXEM, VXK, VXU1
	12357-Z5T-020	TUBE, BREATHER	-	1		LH, LH1, PX, QH, QH1, QHE, QMH, QN, QX, QXE, QXHQ, SH, SH1, SHE, SM11, SWX2, SX, SX1, SXC, SXC1, VTE5, VX, VX1, VX1M, VXE, VXEM
14	95701-10080-00	BOLT, FLANGE, 10X80	4	-		EDF6, EDS1, EDS2, EDT1, ES2, ES3S, ES4S, LH1, LH2, LHB5, LHP1, LXE9, PX, QA2, QBE1, QEBR, QH1, QHB1, QHB3, QHB5, QHBR, QHE, QHP1, QMH, QN, QP, QX, QXBR, QXE, QXEK, QXHQ, QXK, SH1, SWE2, SWX2, SX1, SXC1, SXE1, VMQ3, VMT3, VPKK, VPX4, VPXB, VPXE, VPXJ, VPXK, VPXX, VS4, VS6, VSB4, VSP, VTE5, VX1, VX1M, VXE, VXEK, VXEM, VXK, VXKS, VXU1
	95725-10080-00		4	-		LH, QH, SH
	95701-10080-00		4	-	0000517	SHE, SM11, SX, SXC, SXE, VX
	95701-10080-00		4	-	0000518	SHE, SM11, SX, SXC, SXE, VX
	95701-10080-00		-	4		
15	98079-55846	PLUG, SPARK(BPR5ES)(NGK)	1	1		EDF6, EDS1, EDS2, EDT1, ES2, ES3S, ES4S, VMQ3, VMT3, VS4, VS6, VSB4
	98079-55876		(1)	(1)		ES2, VMQ3, VMT3, VS4, VS6, VSB4, VSP
	98079-56846	PLUG, SPARK(BPR6ES)(NGK)	1	1		LH, LH1, LH2, LHB5, LHP1, LXE9, PX, QA2, QBE1, QEBR, QH, QH1, QHB1, QHB3, QHB5, QHBR, QHE, QHP1, QMH, QN, QP, QX, QXBR, QXE, QXEK, QXHQ, QXK, SH, SH1, SHE, SM11, SWE2, SWX2, SX, SX1, SXC, SXC1, SXE, SXE1, VPKK, VPX4, VPXB, VPXE, VPXJ, VPXK, VPXX, VSP, VTE5, VX, VX1, VX1M, VXE, VXEK, VXEM, VXK, VXKS, VXU1
	98079-55846	PLUG, SPARK(BPR5ES)(NGK)	(1)	(1)		LH, LH1, LH2, LHB5, LHP1, LXE9, PX, QA2, QBE1, QEBR, QH, QH1, QHB1, QHB3, QHB5, QHBR, QHE, QHP1, QMH, QN, QP, QX, QXBR, QXE, QXEK, QXHQ, QXK, SH, SH1, SHE, SM11, SWE2, SWX2, SX, SX1, SXC, SXC1, SXE, SXE1, VPKK, VPX4, VPXB, VPXE, VPXJ, VPXK, VPXX, VTE5, VX, VX1, VX1M, VXE, VXEK, VXEM, VXK, VXKS, VXU1
	98079-55855	PLUG, SPARK(W16EPR-U)(DENSO)	1	-		EDF6
	98079-55855		(1)	-		EDS1, EDS2, EDT1, ES2, ES3S, ES4S, LH, QA2, QH, QHE, QXHQ, SH, SHE, SM11, SX, SXC, SXE, VMQ3, VMT3, VPKK, VPX4, VPXB, VPXE, VPXJ, VPXK, VPXX, VS4, VS6, VSB4, VX, VXEK, VXKS
	98079-56855	PLUG, SPARK(W20EPR-U)(DENSO)	1	-		QA2, VPKK, VPX4, VPXB, VPXE, VPXJ, VPXK, VPXX, VXEK, VXKS
	98079-55855	PLUG, SPARK(W16EPR-U)(DENSO)	-	(1)		LH, QH, QHE, QXHQ, SH, SHE, SM11, SX, SXC, VPKK, VPXB, VPXE, VPXK, VPXX, VX, VXEK, VXKS
16	18330-ZE3-710	PIPE, EX.	1	1		EDF6, EDS1, EDS2, EDT1, ES2, ES3S, ES4S, VMT3, VS4, VS6, VSB4
	18330-ZE3-700		1	-		VMQ3



E-2

CYLINDER HEAD

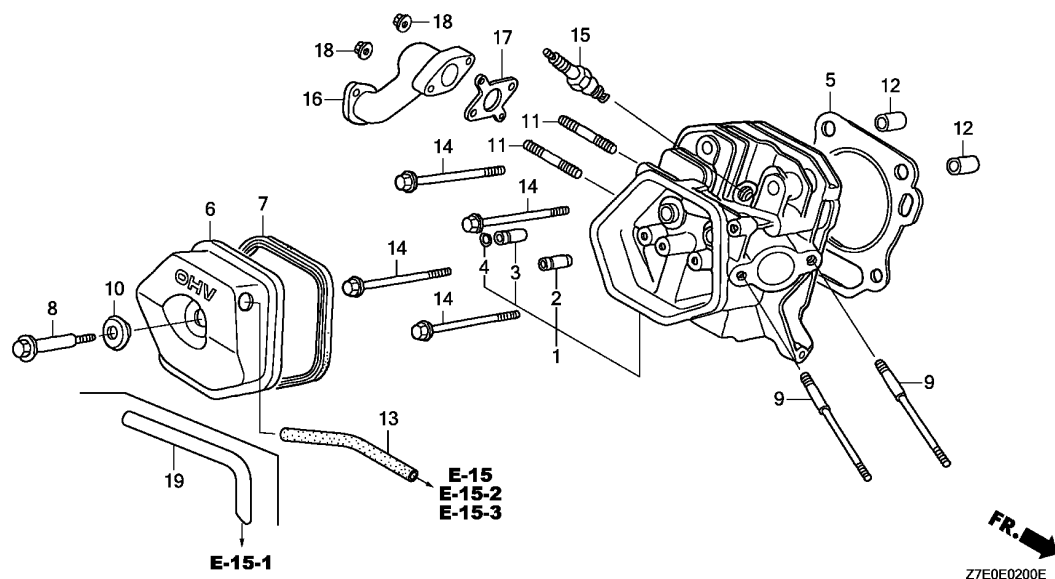

Z7E0E0200E

Ref. No.	Part No.	Description	Reqd. QTY		Serial No.	Parts catalogue code
			GX 390 H1	GX 390 H2		
17	18333-ZF6-W01	GASKET, EX. PIPE	1	-	-----	EDF6,EDS1,EDS2,EDT1,ES2,ES3S,ES4S,VMQ3,VMT3,VS4,VS6,VS64
18	94050-08000	NUT, FLANGE, 8MM	-	1	-----	EDS1,EDS2,EDT1,ES2,VPKK,VPXE,VPXK,VPXX
19	15721-ZB4-000	TUBE, BREATHER	1	-	-----	EDF6,EDS1,EDS2,EDT1,ES2,ES3S,ES4S,VMQ3,VMT3,VS4,VS6,VS64
	15721-Z23-H60	-	1	-----	EDF6,EDS1,EDS2,EDT1,ES3S,ES4S,VPKK,VPX4,VPXB,VPXE,VPXJ,VPXK,VPXX,VXEK VXKS
					-----	EDS1,EDS2,EDT1,ES2,VPKK,VPXB,VPXE,VPXK,VPXX,VXEK,VXKS

E-3

CYLINDER BARREL

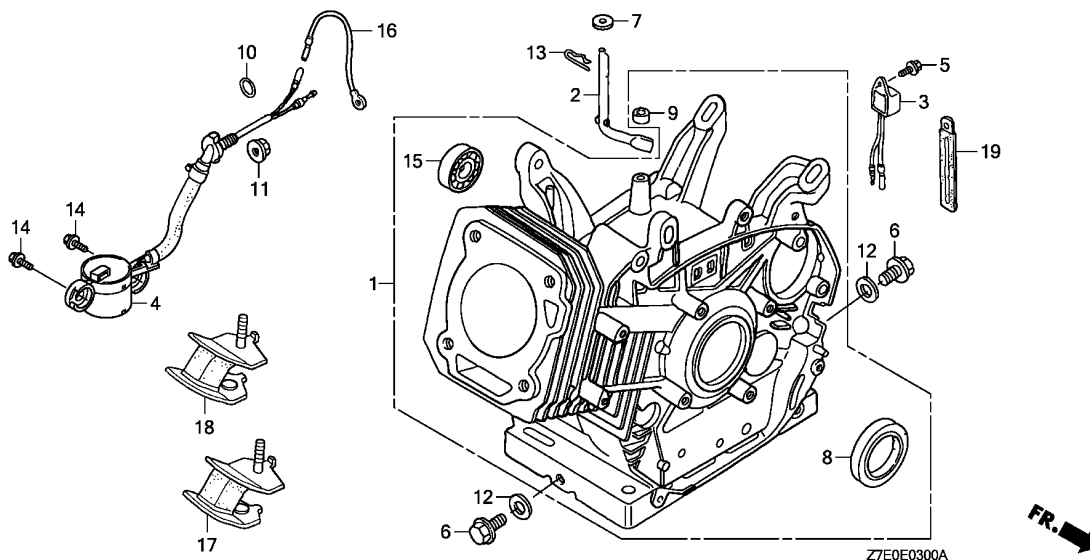

Ref. No.	L.O.N.	(Relative ref. Number) Description	F.R.T.
1	1101A0	BARREL, CYLINDER	1.8
2	1161B4	SHAFT, GOVERNOR ARM	0.9
3	6151A0	ALERT UNIT, ENGINE OIL	0.1
4		(10)	
	6151E8	SWITCH, OIL LEVEL	0.5
8	1101E4	OIL SEAL, CRANKSHAFT :FRONT ..	1.8
9	1101C4	OIL SEAL, GOVERNOR ARM SHAFT ..	0.9
15	1101F4	BEARING, BALANCER WEIGHT :FRONT	1.9

Ref. No.	Part No.	Description	Reqd. QTY		Serial No.	Parts catalogue code
			GX 390 H1	GX 390 H2		
1	12000-Z7E-408	BARREL ASSY., CYLINDER (SELFSTARTER+ALERT)	1	-	EDF6,QHE,SHE,SWE2	
	12000-Z7E-407	1	-	EDS1,EDS2,ES4S,LXE9,QBE1,QEBR,QXE,QXEK,SXE,SXE1,VMT3,VPKK,VPXE,VPXJ,VPXK,VPXX,VS6,VTE5,VXE,VXEK,VXEM,VXK,VXU1	
	12000-Z7E-406	BARREL ASSY., CYLINDER(ALERT)	1	-	EDT1,ES2,ES3S,PX,QA2,QX,QXBR,QXHQ,QXK,SWX2,SX,SX1,SXC,SXC1,VMQ3,VPX4,VPXB,VS4,VS6,VSP,VX,VX1,VX1M,VXKS	
	12000-Z7E-405	BARREL ASSY., CYLINDER	1	-	LH,LH1,LH2,LHB5,LHP1,QH,QH1,QHB1,QHB3,QHB5,QHBR,QHP1,QMH,QN,QP,SH,SH1,SM11	
	12000-Z5T-405	BARREL ASSY., CYLINDER (SELFSTARTER+ALERT)	-	1	EDS1,EDS2,QXE,VPKK,VPXE,VPXK,VPXX,VTE5,VXE,VXEK,VXEM	
	12000-Z5T-407	BARREL ASSY., CYLINDER(ALERT)	-	1	EDT1,ES2,PX,QX,QXHQ,SWX2,SX,SX1,SXC,SXC1,VPXB,VX,VX1,VX1M,VXKS	
	12000-Z5T-406	BARREL ASSY., CYLINDER	-	1	LH,LH1,QH,QH1,QMH,QN,SH,SH1,SM11	
	12000-Z5T-408	-	1	QHE,SHE	
2	16541-Z7E-000	SHAFT, GOVERNOR ARM	1	-	EDF6,EDS2,ES2,ES3S,ES4S,LH,LH1,LH2,LHB5,LHP1,LXE9,PX,QA2,QBE1,QEBR,QH,QH1,QHB1,QHB3,QHB5,QHBR,QHE,QHP1,QMH,QN,QP,QX,QXBR,QXE,QXEK,QXHQ,QXK,SH,SH1,SHE,SM11,SWE2,SWX2,SX,SX1,SXC,SXC1,SXE,SXE1,VMQ3,VMT3,VPKK,VPXB,VPXE,VPXJ,VPXK,VPXX,VS4,VS6,VS6,VS4,VTE5,VX,VX1,VX1M,VXE,VXEK,VXEM,VXK,VXKS,VXU1	
	16541-ZE3-010	1	-	0001591 EDS1,EDT1	
	16541-Z7E-000	1	-	0001966 VPX4,VSP	
		1	-	0001592 EDS1,EDT1	
		1	-	0001967 VPX4,VSP	
		-	1		
3	34150-ZH7-023	ALERT UNIT, OIL	1	-	EDF6,EDS2,QXBR,VPKK,VPXJ,VPXK,VPXX,VX1M,VXEK,VXKS	
	34150-ZH7-013	1	-	0303719 EDS1,EDT1,ES2,ES3S,ES4S,PX,QA2,QX,QXHQ,QXK,SWX2,SX,SX1,SXC,SXC1,VMQ3,VPX4,VPXB,VPXE,VS4,VS6,VS6,VS4,VSP,VX,VX1	
	34150-ZH7-023	1	-	0303720 EDS1,EDT1,ES2,ES3S,ES4S,PX,QA2,QX,QXHQ,QXK,SWX2,SX,SX1,SXC,SXC1,VMQ3,VPX4,VPXB,VPXE,VS4,VS6,VS6,VS4,VSP,VX,VX1	



E-3

CYLINDER BARREL

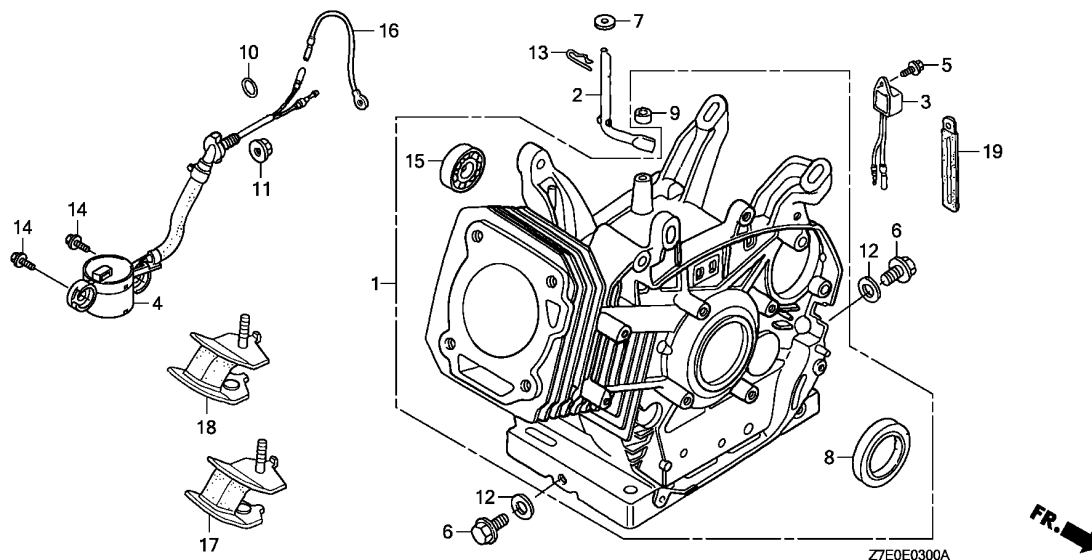

Ref. No.	Part No.	Description	Reqd. QTY		Serial No.	Parts catalogue code
			GX 390 H1	GX 390 H2		
4	35480-Z7E-003	SWITCH ASSY., OIL LEVEL	1	1	-----	EDF6,EDS1,EDS2,EDT1,ES2,ES3S,ES4S,LXE9,PX,QA2,QEBR,QX,QXBR,QXE,QXEK,QXHQ,QXK,SWX2,SX,SX1,SXC,SXC1,SXE,SXE1,VMQ3,VMT3,VPKK,VPX4,VPXB,VPXE,VPXJ,VPXK,VPXX,VS4,VS6,VS6,VS4,VTE5,VX,VX1,VX1M,VXE,VXEK,VXEM,VXK,VXKS,VXU1
	35480-ZF6-003	1	-	0013634	VSP
	35480-Z7E-003	1	-	0013635	VSP
5	90013-883-000	BOLT, FLANGE, 6X12(CT200) ...	1	-	-----	EDF6,EDS1,EDS2,EDT1,ES2,ES3S,ES4S,PX,QA2,QX,QXBR,QXHQ,QXK,SWX2,SX,SX1,SXC,SXC1,VMQ3,VPKK,VPX4,VPXB,VPXE,VPXJ,VPXK,VPXX,VS4,VS6,VS6,VS4,VSP,VX,VX1,VX1M,VXEK,VXKS
6	90131-883-000	BOLT, DRAIN PLUG, 12X15	2	2	-----	
7	90446-Z7E-000	WASHER, 8.2X17X0.8	1	-	-----	EDF6,EDS2,ES2,ES3S,ES4S,LH,LH1,LH2,LHB5,LHP1,LXE9,PX,QA2,QBE1,QEBR,QH,QH1,QHB1,QHB3,QHB5,QHBR,QHE,QHP1,QMH,QN,QP,QX,QXBR,QXE,QXEK,QXHQ,QXK,SH,SH1,SHE,SM11,SWE2,SWX2,SX,SX1,SXC,SXC1,SXE,SXE1,VMQ3,VMT3,VPKK,VPXB,VPXE,VPXJ,VPXK,VPXX,VS4,VS6,VS6,VS4,VTE5,VX,VX1,VX1M,VXE,VXEK,VXEM,VXK,VXKS,VXU1
	90446-KE1-000	1	-	0001591	EDS1,EDT1,VPX4,VSP
	90446-Z7E-000	1	-	0001592	EDS1,EDT1,VPX4,VSP
		-	1		
8	91201-Z7E-003	OIL SEAL, 35X52X8	1	-	-----	EDF6,EDS2,ES2,ES3S,ES4S,LH,LH1,LH2,LHB5,LHP1,LXE9,PX,QA2,QBE1,QEBR,QH,QH1,QHB1,QHB3,QHB5,QHBR,QHE,QHP1,QMH,QN,QP,QX,QXBR,QXE,QXEK,QXHQ,QXK,SH,SH1,SHE,SM11,SWE2,SWX2,SX,SX1,SXC,SXC1,SXE,SXE1,VMQ3,VMT3,VPKK,VPXB,VPXE,VPXJ,VPXK,VPXX,VS4,VS6,VS6,VS4,VTE5,VX,VX1,VX1M,VXE,VXEK,VXEM,VXK,VXKS,VXU1
	91201-ZE3-004	OIL SEAL, 35X52X8(ARAI)	1	-	-----	EDS1,EDT1
	91201-Z1C-003	OIL SEAL, 35X52X8(NOK)	1	-	0001591	VPX4
	91201-Z7E-003	OIL SEAL, 35X52X8	1	-	0001592	VSP
	91201-Z1C-003	OIL SEAL, 35X52X8(NOK)	-	1		VPX4,VSP

E-3

CYLINDER BARREL

Ref. No.	Part No.	Description	Reqd. QTY		Serial No.	Parts catalogue code	
			GX 390 H1	GX 390 H2			
(8)	91201-27E-003	OIL SEAL, 35X52X8	-	1			
9	91203-27E-003	OIL SEAL, 8X14X5	1	-	-----	EDF6,EDS2,ES2,ES3S,ES4S,LH,LH1,LH2,LHB5,LHP1,LXE9,PX,QA2,QBE1,QEBR,QH,QH1,QHB1,QHB3,QHB5,QHBR,QHE,QHP1,QMH,QN,QP,QX,QXBR,QXE,QXEK,QXHQ,QXK,SH,SH1,SHE,SM11,SWE2,SWX2,SX,SX1,SXC,SXC1,SXE,SXE1,VMQ3,VMT3,VPKK,VPXB,VPXE,VPXJ,VPXK,VPXX,VS4,VS6,VS4,VS6,VS4,VTE5,VX,VX1,VX1M,VXE,VXEK,VXEM,VXK,VXKS,VXU1	
	91203-952-771	1	-	-----	0001591 EDS1,EDT1,VPX4,VSP	
	91203-27E-003	1	-	0001592	-----	EDS1,EDT1,VPX4,VSP
	91203-952-771	-	1			
	91203-27E-003	-	1			
10	91353-27E-003	O-RING, 14MM	1	1	-----	EDF6,EDS1,EDS2,EDT1,ES2,ES3S,ES4S,LXE9,PX,QA2,QEBR,QX,QXBR,QXE,QXEK,QXHQ,QXK,SWX2,SX,SX1,SXC,SXC1,SXE,SXE1,VMQ3,VMT3,VPKK,VPX4,VPXB,VPXE,VPXJ,VPXK,VPXX,VS4,VS6,VS4,VS6,VS4,VTE5,VX,VX1,VX1M,VXE,VXEK,VXEM,VXK,VXKS,VXU1	
	91353-671-004	O-RING, 14MM(NOK)	1	-	-----	0001591 VSP	
	91353-27E-003	O-RING, 14MM	1	-	0001592	-----	VSP
11	94050-10000	NUT, FLANGE, 10MM	1	1	-----	EDF6,EDS1,EDS2,EDT1,ES2,ES3S,ES4S,LXE9,PX,QA2,QEBR,QX,QXBR,QXE,QXEK,QXHQ,QXK,SWX2,SX,SX1,SXC,SXC1,SXE,SXE1,VMQ3,VMT3,VPKK,VPX4,VPXB,VPXE,VPXJ,VPXK,VPXX,VS4,VS6,VS4,VS6,VS4,VTE5,VX,VX1,VX1M,VXE,VXEK,VXEM,VXK,VXKS,VXU1	
12	94109-12000	WASHER, DRAIN PLUG, 12MM	2	2			
13	94251-10000	PIN, LOCK, 10MM	1	1			
14	95701-06012-00	BOLT, FLANGE, 6X12	2	2	-----	EDF6,EDS1,EDS2,EDT1,ES2,ES3S,ES4S,LXE9,PX,QA2,QEBR,QX,QXBR,QXE,QXEK,QXHQ,QXK,SWX2,SX,SX1,SXC,SXC1,SXE,SXE1,VMQ3,VMT3,VPKK,VPX4,VPXB,VPXE,VPXJ,VPXK,VPXX,VS4,VS6,VS4,VS6,VS4,VTE5,VX,VX1,VX1M,VXE,VXEK,VXEM,VXK,VXKS,VXU1	
15	96100-62020-00	BEARING, RADIAL BALL, 6202 ..	1	1			
16	31161-ZE2-000	CORD, EARTH	1	1	-----	ES2,ES3S,ES4S,VS4,VS6,VS4	
17	68325-ZC2-000	RUBBER, BOTTOM	2	2	-----	ES2,ES3S,ES4S,VS4,VS6,VS4	
18	68325-899-000	RUBBER, BOTTOM	2	2	-----	ES2,ES3S,ES4S,VS4,VS6,VS4	
19	91406-166-000	CLIP, WIRE	1	-	-----	ES4S,VMT3,VS6	

2

E-6

CRANKCASE COVER(1)

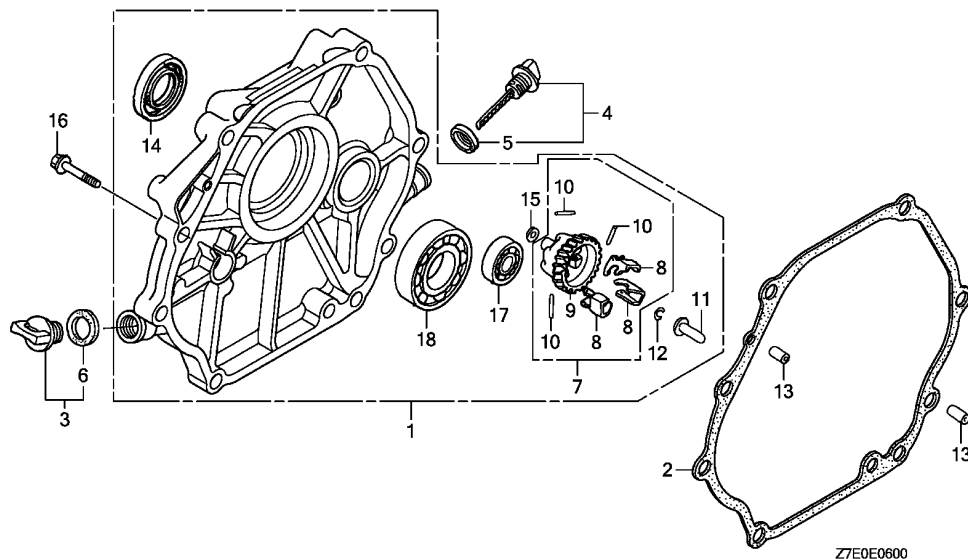

Ref. No.	L.O.N.	(Relative ref. Number) Description	F.R.T.
1	1101F1	COVER, CRANKCASE	0.2
2	1101E9	PACKING, CRANKCASE COVER	0.2
7	1161C4	GOVERNOR ASSEMBLY	0.3
9		(8,10)	
	1161A7	HOLDER, GOVERNOR WEIGHT	0.4
11	1161B6	SLIDER, GOVERNOR	0.3
14	1101E5	OIL SEAL, CRANKSHAFT :REAR ...	0.3
17	1101F5	BEARING, BALANCER WEIGHT :REAR	0.4
18	1101A6	BEARING, CRANKSHAFT :REAR	0.4

Ref. No.	Part No.	Description	Reqd. QTY		Serial No.	Parts catalogue code
			GX 390 H1	GX 390 H2		
1	11300-Z7E-P70 11300-Z7E-800	COVER ASSY., CRANKCASE	1	1	-----	EDF6,EDS2,VS4,VS6 PX,QA2,QBE1,QEBR,QH,QH1,QHB1,QHB3,QHB5,QHBR,QHE,QHP1,QMH,QN,QP,QX QXBR,QXE,QXEK,QXHQ,QXK,VMQ3,VPKK,VPXB,VPXE,VPXJ,VPXK,VPXX,VS4,VS6,VS VX,VX1,VX1M,VXE,VXEK,VXEM,VXK,VXKS,VXU1
	11300-ZE3-P70 11300-Z7E-000 11300-ZE3-604 11300-ZE3-040 11300-Z1C-600 11300-Z7E-000 11300-ZE3-604 11300-Z7E-000	1 1 1 1 1 1 1 1	- - - - - - - -	----- ----- ----- ----- ----- ----- ----- -----	ES3S,ES4S SH,SH1,SHE,SM11,SWE2,SWX2,SX,SX1,SXC,SXC1,SXE,SXE1 VPX4 0000026 EDS1,EDT1 0001148 VSP EDS1,EDT1 0001149 VSP
2	11381-Z7E-701	PACKING, CASE COVER (NINGBO SIL GASKET)	1	1	-----	EDF6,EDS1,EDS2,EDT1,ES3S,ES4S,PX,QA2,QBE1,QEBR,QH,QH1,QHB1,QHB3,QHB5 QHBR,QHE,QHP1,QMH,QN,QP,QX,QXBR,QXE,QXEK,QXHQ,QXK,SH,SH1,SHE,SM11 SWE2,SWX2,SX,SX1,SXC,SXC1,SXE,SXE1,VMQ3,VPKK,VPX4,VPXB,VPXE,VPXJ,VPXK VPXX,VS4,VS6,VS4,VSP,VTE5,VX,VX1,VX1M,VXE,VXEK,VXEM,VXK,VXKS,VXU1
	11381-ZE3-801	PACKING, CASE COVER	1	-	-----	EDF6,EDS1,EDS2,EDT1,ES3S,ES4S,PX,QA2,QBE1,QEBR,QH,QH1,QHB1,QHB3,QHB5 QHBR,QHE,QHP1,QMH,QN,QP,QX,QXBR,QXE,QXEK,QXHQ,QXK,SH,SH1,SHE,SM11 SWE2,SWX2,SX,SX1,SXC,SXC1,SXE,SXE1,VMQ3,VPKK,VPX4,VPXB,VPXE,VPXJ,VPXK VPXX,VS4,VS6,VS4,VSP,VTE5,VX,VX1,VX1M,VXE,VXEK,VXEM,VXK,VXKS,VXU1
	11381-Z5T-000	PACKING, CRANKCASE COVER	-	1	-----	EDS1,EDS2,EDT1,PX,QH,QH1,QHE,QMH,QN,QX,QXE,QXHQ,SH,SH1,SHE,SM11,SWX2 SX,SX1,SXC,SXC1,VPKK,VPXB,VPXE,VPXK,VPXX,VTE5,VX,VX1,VX1M,VXE,VXEK VXEM,VXKS
3	15600-Z1T-600	CAP ASSY., OIL FILLER	1	-	-----	EDF6,EDS2,ES3S,ES4S,PX,QA2,QBE1,QEBR,QH,QH1,QHB1,QHB3,QHB5,QHBR,QHE QHP1,QMH,QN,QP,QX,QXBR,QXE,QXEK,QXHQ,QXK,SH,SH1,SHE,SM11,SWE2,SWX2,SX SX1,SXC,SXC1,SXE,SXE1,VMQ3,VPKK,VPXB,VPXE,VPXJ,VPXK,VPXX,VS4,VS6,VS4 VTE5,VX,VX1,VX1M,VXE,VXEK,VXEM,VXK,VXKS,VXU1

E-6

CRANKCASE COVER(1)

Ref. No.	Part No.	Description	Reqd. QTY		Serial No.	Parts catalogue code
			GX 390 H1	GX 390 H2		
(3)	15600-ZG4-003	CAP ASSY., OIL FILLER	1	-	0001148	EDS1,EDT1
			1	-	0002100	VPX4
	15600-Z0T-820	CAP ASSY., OIL FILLER(BLACK)	1	-	0002100	VSP
	15600-Z1T-600	CAP ASSY., OIL FILLER	1	-	0001149	EDS1,EDT1
			1	-	0002101	VPX4,VSP
			-	1		EDS1,EDS2,EDT1,PX,QH,QH1,QHE,QMH,QN,QX,QXE,QXHQ,SH,SH1,SHE,SM11,SWX2,SX, SX1,SXC,SXC1,VPKK,VPXB,VPXE,VPXK,VPXX,VTE5,VX,VX1,VX1M,VXE,VXEK,VXEM,VXKS
4	15600-Z7E-000	CAP ASSY., OIL FILLER	1	-		EDF6,EDS2,ES3S,ES4S,PX,QA2,QBE1,QEBR,QH,QH1,QHB1,QHB3,QHB5,QHBR,QHE,QHP1,QMH,QN,QP,QX,QXBR,QXE,QXEK,QXHQ,QXK,SH,SH1,SHE,SM11,SWE2,SWX2,SX, SX1,SXC,SXC1,SXE,SXE1,VMQ3,VPKK,VPXB,VPXE,VPXJ,VPXK,VPXX,VS4,VS6,VS B4,VTE5,VX,VX1,VX1M,VXE,VXEK,VXEM,VXK,VXKS,VXU1
	15600-735-003	1	-	0002100	EDS1,EDT1,VPX4
	15600-Z1C-000	1	-	0002100	VSP
	15600-Z7E-000	1	-	0002101	EDS1,EDT1,VPX4,VSP
			-	1		EDS1,EDS2,EDT1,PX,QH,QH1,QHE,QMH,QN,QX,QXE,QXHQ,SH,SH1,SHE,SM11,SWX2,SX, SX1,SXC,SXC1,VPKK,VPXB,VPXE,VPXK,VPXX,VTE5,VX,VX1,VX1M,VXE,VXEK,VXEM,VXKS
5	15625-Z0T-800	PACKING, OIL FILLER CAP	1	-		EDF6,EDS2,ES3S,ES4S,PX,QA2,QBE1,QEBR,QH,QH1,QHB1,QHB3,QHB5,QHBR,QHE,QHP1,QMH,QN,QP,QX,QXBR,QXE,QXEK,QXHQ,QXK,SH,SH1,SHE,SM11,SWE2,SWX2,SX, SX1,SXC,SXC1,SXE,SXE1,VMQ3,VPKK,VPXB,VPXE,VPXJ,VPXK,VPXX,VS4,VS6,VS B4,VSP,VTE5,VX,VX1,VX1M,VXE,VXEK,VXEM,VXK,VXKS,VXU1
	15625-ZE1-003	1	-	0002100	EDS1,EDT1,VPX4
	15625-Z0T-800	1	-	0002101	EDS1,EDT1,VPX4
				-	1	
6	15625-Z1T-000	PACKING, OIL FILLER CAP	1	-		EDF6,EDS2,ES3S,ES4S,PX,QA2,QBE1,QEBR,QH,QH1,QHB1,QHB3,QHB5,QHBR,QHE,QHP1,QMH,QN,QP,QX,QXBR,QXE,QXEK,QXHQ,QXK,SH,SH1,SHE,SM11,SWE2,SWX2,SX, SX1,SXC,SXC1,SXE,SXE1,VMQ3,VPKK,VPXB,VPXE,VPXJ,VPXK,VPXX,VS4,VS6,VS B4,VTE5,VX,VX1,VX1M,VXE,VXEK,VXEM,VXK,VXKS,VXU1
	15625-ZE1-003	1	-	0001148	EDS1,EDT1
			1	-	0002100	VPX4
	15625-Z0T-800	1	-	0002100	VSP
	15625-Z1T-000	1	-	0001149	EDS1,EDT1
				-	1	
7	16510-Z7E-000	GOVERNOR ASSY.	1	-		EDF6,EDS2,PX,QA2,QBE1,QEBR,QH,QH1,QHB1,QHB3,QHB5,QHBR,QHE,QHP1,QMH,QN,QP,QX,QXBR,QXE,QXEK,QXHQ,QXK,SH,SH1,SHE,SM11,SWE2,SWX2,SX, SX1,SXC,SXC1,SXE,SXE1,VMQ3,VPKK,VPXB,VPXE,VPXJ,VPXK,VPXX,VS4,VS6,VS B4,VTE5,VX,VX1,VX1M,VXE,VXEK,VXEM,VXK,VXKS,VXU1
	16510-ZE3-000	1	-		ES3S,ES4S,VPX4,VSP
	16510-Z7E-000	1	-	0001591	EDS1,EDT1
				-	1	
8	16511-ZE8-000	WEIGHT, GOVERNOR	3	3		EDF6,EDS1,EDS2,EDT1,ES3S,ES4S,PX,QA2,QBE1,QEBR,QH,QH1,QHB1,QHB3,QHB5,QHBR,QHE,QHP1,QMH,QN,QP,QX,QXBR,QXE,QXEK,QXHQ,QXK,SH,SH1,SHE,SM11,SWE2,SWX2,SX, SX1,SXC,SXC1,SXE,SXE1,VMQ3,VPKK,VPX4,VPXB,VPXE,VPXJ,VPXK,VPXX,VS4,VS6,VS B4,VSP,VTE5,VX,VX1,VX1M,VXE,VXEK,VXEM,VXK,VXKS,VXU1
9	16512-Z7E-000	HOLDER, GOVERNOR WEIGHT	1	-		EDF6,EDS2,PX,QA2,QBE1,QEBR,QH,QH1,QHB1,QHB3,QHB5,QHBR,QHE,QHP1,QMH,QN,QP,QX,QXBR,QXE,QXEK,QXHQ,QXK,SH,SH1,SHE,SM11,SWE2,SWX2,SX, SX1,SXC,SXC1,SXE,SXE1,VMQ3,VPKK,VPXB,VPXE,VPXJ,VPXK,VPXX,VS4,VS6,VS B4,VTE5,VX,VX1,VX1M,VXE,VXEK,VXEM,VXK,VXKS,VXU1



E-6

CRANKCASE COVER(1)

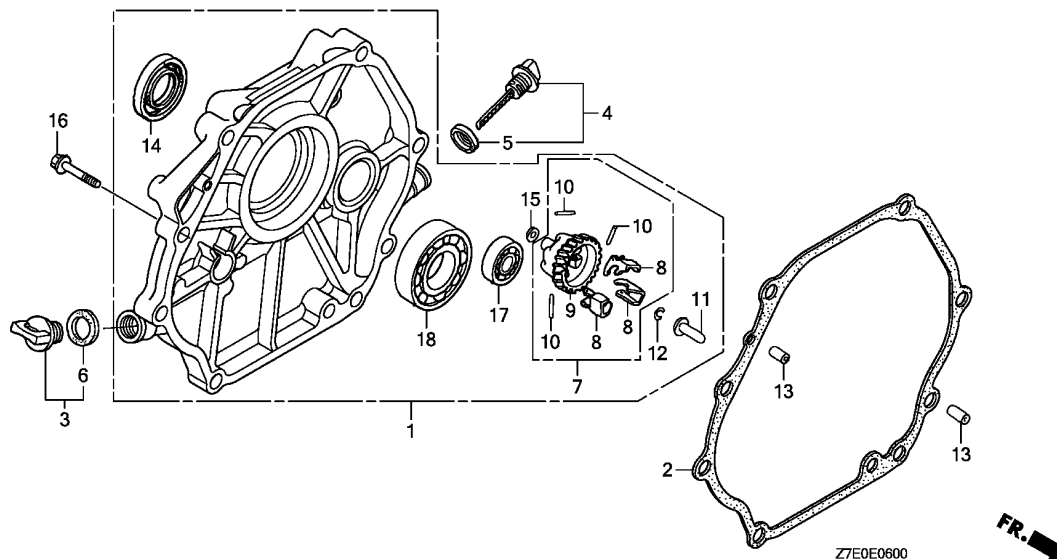

Ref. No.	Part No.	Description	Reqd. QTY		Serial No.	Parts catalogue code
			GX 390 H1	GX 390 H2		
(9)	16512-ZE3-000	HOLDER, GOVERNOR WEIGHT	1	-	-----	ES3S,ES4S,VPX4,VSP
	16512-Z7E-000	1	-	0001591	EDS1,EDT1
			-	1	0001592	EDS1,EDT1
						EDS1,EDS2,EDT1,PX,QH,QH1,QHE,QMH,QN,QX,QXE,QXHQ,SH,SH1,SHE,SM11,SWX2,SX,SX1,SXC,SXC1,VPKK,VPXB,VPXE,VPXK,VPXX,VTE5,VX,VX1,VX1M,VXE,VXEK,VXEM,VXKS
10	16513-ZE2-000	PIN, GOVERNOR WEIGHT	3	3	-----	EDF6,EDS1,EDS2,EDT1,ES3S,ES4S,PX,QA2,QBE1,QEBR,QH,QH1,QHB1,QHB3,QHB5,QHBR,QHE,QHP1,QMH,QN,QP,QX,QXBR,QXE,QXEK,QXHQ,QXK,SH,SH1,SHE,SM11,SWE2,SWX2,SX,SX1,SXC,SXC1,SXE,SXE1,VMQ3,VPKK,VPX4,VPXB,VPXE,VPXJ,VPXK,VPXX,VS4,VS6,VS4,VS6,VS4,VSP,VTE5,VX,VX1,VX1M,VXE,VXEK,VXEM,VXK,VXKS,VXU1
11	16531-Z0A-000	SLIDER, GOVERNOR	1	1	-----	EDF6,EDS1,EDS2,EDT1,ES3S,ES4S,PX,QA2,QBE1,QEBR,QH,QH1,QHB1,QHB3,QHB5,QHBR,QHE,QHP1,QMH,QN,QP,QX,QXBR,QXE,QXEK,QXHQ,QXK,SH,SH1,SHE,SM11,SWE2,SWX2,SX,SX1,SXC,SXC1,SXE,SXE1,VMQ3,VPKK,VPX4,VPXB,VPXE,VPXJ,VPXK,VPXX,VS4,VS6,VS4,VSP,VTE5,VX,VX1,VX1M,VXE,VXEK,VXEM,VXK,VXKS,VXU1
12	90602-ZE1-000	CLIP, GOVERNOR HOLDER	1	1	-----	EDF6,EDS1,EDS2,EDT1,ES3S,ES4S,PX,QA2,QBE1,QEBR,QH,QH1,QHB1,QHB3,QHB5,QHBR,QHE,QHP1,QMH,QN,QP,QX,QXBR,QXE,QXEK,QXHQ,QXK,SH,SH1,SHE,SM11,SWE2,SWX2,SX,SX1,SXC,SXC1,SXE,SXE1,VMQ3,VPKK,VPX4,VPXB,VPXE,VPXJ,VPXK,VPXX,VS4,VS6,VS4,VSP,VTE5,VX,VX1,VX1M,VXE,VXEK,VXEM,VXK,VXKS,VXU1
13	90701-Z7E-000	DOWEL PIN, 8X12	2	-	-----	EDF6,EDS2,ES3S,ES4S,PX,QA2,QBE1,QEBR,QH,QH1,QHB1,QHB3,QHB5,QHBR,QHE,QHP1,QMH,QN,QP,QX,QXBR,QXE,QXEK,QXHQ,QXK,SH,SH1,SHE,SM11,SWE2,SWX2,SX,SX1,SXC,SXC1,SXE,SXE1,VMQ3,VPKK,VPXB,VPXE,VPXJ,VPXK,VPXX,VS4,VS6,VS4,VTE5,VX,VX1,VX1M,VXE,VXEK,VXEM,VXK,VXKS,VXU1
	90701-HC4-000	2	-	0001591	EDS1,EDT1,VPX4,VSP
	90701-Z7E-000	2	-	0001592	EDS1,EDT1,VPX4,VSP
			-	2	-----	EDS1,EDS2,EDT1,PX,QH,QH1,QHE,QMH,QN,QX,QXE,QXHQ,SH,SH1,SHE,SM11,SWX2,SX,SX1,SXC,SXC1,VPKK,VPXB,VPXE,VPXK,VPXX,VTE5,VX,VX1,VX1M,VXE,VXEK,VXEM,VXKS

E-6

CRANKCASE COVER(1)

Ref. No.	Part No.	Description	Reqd. QTY		Serial No.	Parts catalogue code
			GX 390 H1	GX 390 H2		
14	91201-Z7E-003	OIL SEAL, 35X52X8	1	-	-	EDF6,EDS2,PX,QA2,QBE1,QEBR,QH,QH1,QHB1,QHB3,QHB5,QHBR,QHE,QHP1,QMH,QN,QP,QX,QXBR,QXE,QXEK,QXHQ,QXK,SH,SH1,SHE,SM11,SWE2,SWX2,SX,SX1,SXC,SXC1,SXE,SXE1,VMQ3,VPKK,VPXB,VPXE,VPXJ,VPXK,VPXX,VS4,VS6,VSB4,VTE5,VX,VX1,VX1M,VXE,VXEK,VXEM,VXK,VXKS,VXU1
	91201-ZE3-004	OIL SEAL, 35X52X8(ARAI)	1	-	-	ES3S,ES4S,VPX4
	91201-Z1C-003	OIL SEAL, 35X52X8(NOK)	1	-	0001148	VSP
	91201-ZE3-004	OIL SEAL, 35X52X8(ARAI)	1	-	0001591	EDS1,EDT1
			1	-	0001149	VSP
	91201-Z7E-003	OIL SEAL, 35X52X8	1	-	0001592	EDS1,EDT1
			-	1	-	EDS1,EDS2,EDT1,PX,QH,QH1,QHE,QMH,QN,QX,QXE,QXHQ,SH,SH1,SHE,SM11,SWX2,SX,SX1,SXC,SXC1,VPKK,VPXB,VPXE,VPXK,VPXX,VTE5,VX,VX1,VX1M,VXE,VXEK,VXEM,VXKS
15	94101-06800	WASHER, PLAIN, 6MM	1	1	-	EDF6,EDS1,EDS2,EDT1,ES3S,ES4S,PX,QA2,QBE1,QEBR,QH,QH1,QHB1,QHB3,QHB5,QHBR,QHE,QHP1,QMH,QN,QP,QX,QXBR,QXE,QXEK,QXHQ,QXK,SH,SH1,SHE,SM11,SWE2,SWX2,SX,SX1,SXC,SXC1,SXE,SXE1,VMQ3,VPKK,VPX4,VPXB,VPXE,VPXJ,VPXK,VPXX,VS4,VS6,VSB4,VSP,VTE5,VX,VX1,VX1M,VXE,VXEK,VXEM,VXK,VXKS,VXU1
16	95701-08040-00	BOLT, FLANGE, 8X40	7	7	-	EDF6,EDS1,EDS2,EDT1,ES3S,ES4S,PX,QA2,QBE1,QEBR,QH,QH1,QHB1,QHB3,QHB5,QHBR,QHE,QHP1,QMH,QN,QP,QX,QXBR,QXE,QXEK,QXHQ,QXK,SH,SH1,SHE,SM11,SWE2,SWX2,SX,SX1,SXC,SXC1,SXE,SXE1,VMQ3,VPKK,VPX4,VPXB,VPXE,VPXJ,VPXK,VPXX,VS4,VS6,VSB4,VSP,VTE5,VX,VX1,VX1M,VXE,VXEK,VXEM,VXK,VXKS,VXU1
17	96100-62020-00	BEARING, RADIAL BALL, 6202 ..	1	1	-	EDF6,EDS1,EDS2,EDT1,ES3S,ES4S,PX,QA2,QBE1,QEBR,QH,QH1,QHB1,QHB3,QHB5,QHBR,QHE,QHP1,QMH,QN,QP,QX,QXBR,QXE,QXEK,QXHQ,QXK,SH,SH1,SHE,SM11,SWE2,SWX2,SX,SX1,SXC,SXC1,SXE,SXE1,VMQ3,VPKK,VPX4,VPXB,VPXE,VPXJ,VPXK,VPXX,VS4,VS6,VSB4,VSP,VTE5,VX,VX1,VX1M,VXE,VXEK,VXEM,VXK,VXKS,VXU1
18	96100-62070-00	BEARING, RADIAL BALL, 6207 ..	1	1	-	EDF6,EDS1,EDS2,EDT1,ES3S,ES4S,PX,QA2,QBE1,QEBR,QH,QH1,QHB1,QHB3,QHB5,QHBR,QHE,QHP1,QMH,QN,QP,QX,QXBR,QXE,QXEK,QXHQ,QXK,SH,SH1,SHE,SM11,SWE2,SWX2,SX,SX1,SXC,SXC1,SXE,SXE1,VMQ3,VPKK,VPX4,VPXB,VPXE,VPXJ,VPXK,VPXX,VS4,VS6,VSB4,VSP,VTE5,VX,VX1,VX1M,VXE,VXEK,VXEM,VXK,VXKS,VXU1
	91001-Z7E-003	1	-	-	EDF6,EDS2,ES3S,ES4S,QHE,VPKK,VPXK,VPXX,VX1M,VXEK,VXEM,VXKS
			1	-	0449985	EDS1,EDT1,PX,QA2,QBE1,QEBR,QH,QH1,QHB1,QHB3,QHB5,QHBR,QHP1,QMH,QN,QP,QX,QXBR,QXE,QXEK,QXHQ,QXK,SH,SH1,SHE,SM11,SWE2,SWX2,SX,SX1,SXC,SXC1,SXE,SXE1,VMQ3,VPX4,VPXB,VPXE,VPXJ,VS4,VS6,VSB4,VSP,VTE5,VX,VX1,VXE,VXK,VXU1
			-	1	-	EDS1,EDS2,EDT1,PX,QH,QH1,QHE,QMH,QN,QX,QXE,QXHQ,SH,SH1,SHE,SM11,SWX2,SX,SX1,SXC,SXC1,VPKK,VPXB,VPXE,VPXK,VPXX,VTE5,VX,VX1,VX1M,VXE,VXEK,VXEM,VXKS



E-6-1

CRANKCASE COVER(2)

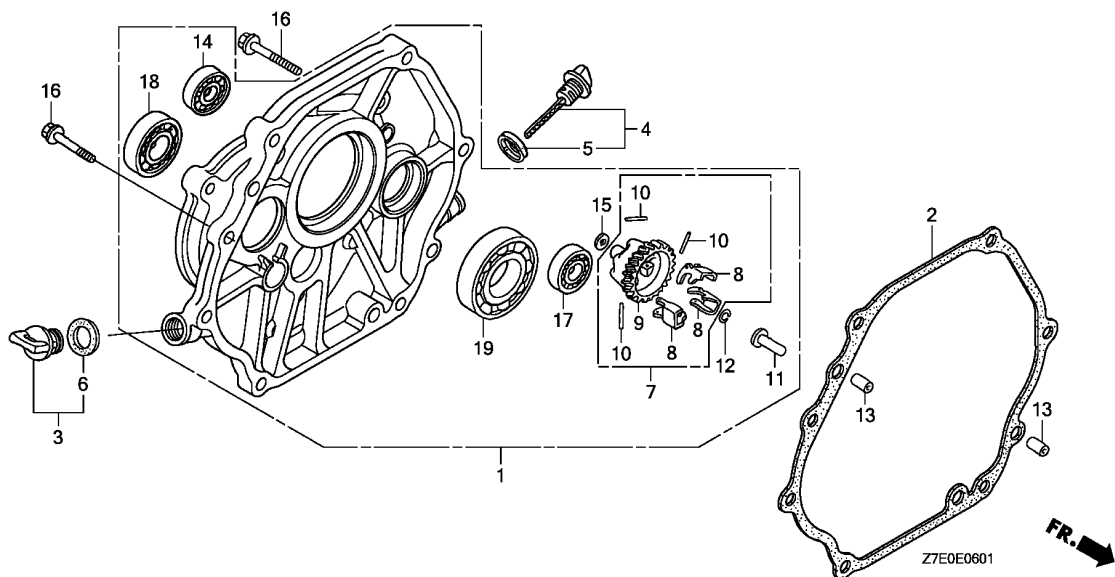

Ref. No.	L.O.N.	(Relative ref. Number) Description	F.R.T.
1	1101G0	COVER, CRANKCASE(A)	0.3
2	1101F9	PACKING, CRANKCASE COVER(A) ..	0.3
7	1161C4	GOVERNOR ASSEMBLY	0.3
9		(8,10)	
	1161C6	HOLDER, GOVERNOR WEIGHT(A) ...	0.4
11	1161C7	SLIDER, GOVERNOR(A)	0.3
14	2101U3	BEARING, COUNTERSHAFT :FRONT	0.4
17	1101G5	BEARING, BALANCER WEIGHT(A) :REAR	0.4
18	2141A7	BEARING, POWER TAKE OFF SHAFT :FRONT	0.4
19	1101G4	BEARING, CRANKSHAFT(A) :REAR	0.4

Ref. No.	Part No.	Description	Reqd. QTY		Serial No.	Parts catalogue code
			GX 390 H1	GX 390 H2		
1	11300-Z7E-810	COVER ASSY., CRANKCASE	1	1	-----	LH,LH1,LH2,LHB5,LHP1,LXE9
2	11381-Z7E-701	PACKING, CASE COVER (NINGBO SIL GASKET)	1	1	-----	LH,LH1,LH2,LHB5,LHP1,LXE9
	11381-ZE3-801	PACKING, CASE COVER	1	-	-----	LH,LH1,LH2,LHB5,LHP1,LXE9
	11381-Z5T-000	PACKING, CRANKCASE COVER	-	1	-----	LH,LH1
3	15600-Z1T-600	CAP ASSY., OIL FILLER	1	1	-----	LH,LH1,LH2,LHB5,LHP1,LXE9
4	15600-Z7E-000	CAP ASSY., OIL FILLER	1	1	-----	LH,LH1,LH2,LHB5,LHP1,LXE9
5	15625-Z0T-800	PACKING, OIL FILLER CAP	1	1	-----	LH,LH1,LH2,LHB5,LHP1,LXE9
6	15625-Z1T-000	PACKING, OIL FILLER CAP	1	1	-----	LH,LH1,LH2,LHB5,LHP1,LXE9
7	16510-Z7E-000	GOVERNOR ASSY.	1	1	-----	LH,LH1,LH2,LHB5,LHP1,LXE9
8	16511-ZE8-000	WEIGHT, GOVERNOR	3	3	-----	LH,LH1,LH2,LHB5,LHP1,LXE9
9	16512-Z7E-000	HOLDER, GOVERNOR WEIGHT	1	1	-----	LH,LH1,LH2,LHB5,LHP1,LXE9
10	16513-ZE2-000	PIN, GOVERNOR WEIGHT	3	3	-----	LH,LH1,LH2,LHB5,LHP1,LXE9
11	16531-Z0A-000	SLIDER, GOVERNOR	1	1	-----	LH,LH1,LH2,LHB5,LHP1,LXE9
12	90602-ZE1-000	CLIP, GOVERNOR HOLDER	1	1	-----	LH,LH1,LH2,LHB5,LHP1,LXE9
13	90701-Z7E-000	DOWEL PIN, 8X12	2	2	-----	LH,LH1,LH2,LHB5,LHP1,LXE9
14	91009-KJ1-003	BEARING, RADIAL BALL, 6202 (NTN)	1	1	-----	LH,LH1,LH2,LHB5,LHP1,LXE9
15	94101-06800	WASHER, PLAIN, 6MM	1	1	-----	LH,LH1,LH2,LHB5,LHP1,LXE9
16	95701-08040-00	BOLT, FLANGE, 8X40	7	7	-----	LH,LH1,LH2,LHB5,LHP1,LXE9
17	96100-62020-00	BEARING, RADIAL BALL, 6202 ..	1	1	-----	LH,LH1,LH2,LHB5,LHP1,LXE9
18	96100-62040-00	BEARING, RADIAL BALL, 6204 ..	1	1	-----	LH,LH1,LH2,LHB5,LHP1,LXE9
19	96100-62070-00	BEARING, RADIAL BALL, 6207 ..	1	1	-----	LH,LH1,LH2,LHB5,LHP1,LXE9
	91001-Z7E-003	1	-	0449985	LH,LH1,LH2,LHB5,LHP1,LXE9
			-	1	-----	LH,LH1

E-6-2

CRANKCASE COVER(3)

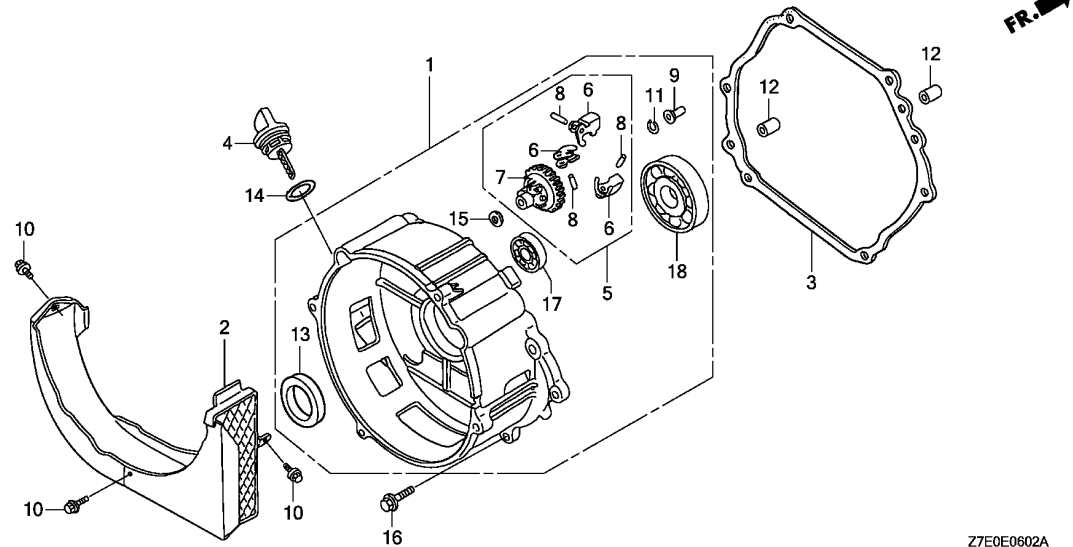

Z7E0E0602A

Ref. No.	L.O.N.	(Relative ref. Number) Description	F.R.T.
1	1101G0	COVER, CRANKCASE(A)	0.3
2	4141J5	COVER, DUCT	0.1
3	1101F9	PACKING, CRANKCASE COVER(A) ..	0.3
5	1161C4	GOVERNOR ASSEMBLY	0.3
7		(6,8)	
	1161A7	HOLDER, GOVERNOR WEIGHT	0.4
9	1161B6	SLIDER, GOVERNOR	0.3
13	1101E5	OIL SEAL, CRANKSHAFT :REAR ...	0.3
17	1101F5	BEARING, BALANCER WEIGHT :REAR	0.4
18	1101A6	BEARING, CRANKSHAFT :REAR	0.4

Ref. No.	Part No.	Description	Reqd. QTY		Serial No.	Parts catalogue code
			GX 390 H1	GX 390 H2		
1	11300-Z7E-700	COVER ASSY., CRANKCASE(E-TYPE)	1	1	-----	ES2,VMT3
2	11315-ZE3-700	COVER, DUCT	1	-	-----	VMT3
3	11381-Z7E-701	PACKING, CASE COVER	1	1	-----	ES2,VMT3
	11381-ZE3-801	PACKING, CASE COVER	1	-	-----	ES2,VMT3
	11381-Z5T-000	PACKING, CRANKCASE COVER	-	1	-----	ES2
4	15620-Z7E-800	CAP, OIL FILLER	1	1	-----	ES2,VMT3
5	16510-Z7E-000	GOVERNOR ASSY.	1	1	-----	ES2,VMT3
6	16511-ZE8-000	WEIGHT, GOVERNOR	3	3	-----	ES2,VMT3
7	16512-Z7E-000	HOLDER, GOVERNOR WEIGHT	1	1	-----	ES2,VMT3
8	16513-ZE2-000	PIN, GOVERNOR WEIGHT	3	3	-----	ES2,VMT3
9	16531-Z0A-000	SLIDER, GOVERNOR	1	1	-----	ES2,VMT3
10	90019-883-000	BOLT, FLANGE, 5X10(CT200) ...	3	-	-----	VMT3
11	90602-ZE1-000	CLIP, GOVERNOR HOLDER	1	1	-----	ES2,VMT3
12	90701-Z7E-000	DOWEL PIN, 8X12	2	2	-----	ES2,VMT3
13	91201-Z7E-003	OIL SEAL, 35X52X8	1	1	-----	ES2,VMT3
14	91301-805-000	O-RING, 26X2.7	1	1	-----	ES2,VMT3
15	94101-06800	WASHER, PLAIN, 6MM	1	1	-----	ES2,VMT3
16	95701-08040-00	BOLT, FLANGE, 8X40	7	7	-----	ES2,VMT3
17	96100-62020-00	BEARING, RADIAL BALL, 6202 ..	1	1	-----	ES2,VMT3
18	96100-62070-00	BEARING, RADIAL BALL, 6207 ..	1	1	-----	ES2,VMT3
	91001-Z7E-003	1	-	0449985	ES2,VMT3
			-	1	-----	ES2

E-7

CRANKSHAFT

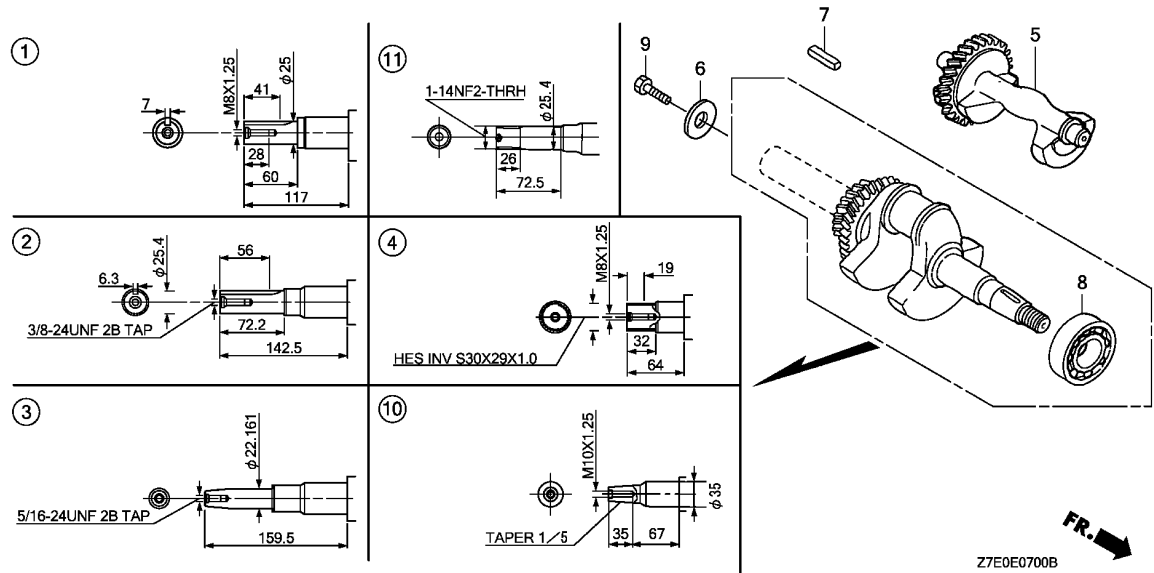

Ref. No.	L.O.N.	(Relative ref. Number) Description	F.R.T.
1		(2,3,4,10,11)	
1101F0		CRANKSHAFT	1.1
1101D8		WEIGHT, BALANCER	0.4
1101A4		BEARING, CRANKSHAFT :FRONT ...	1.3

2

Ref. No.	Part No.	Description	Reqd. QTY		Serial No.	Parts catalogue code
			GX 390 H1	GX 390 H2		
1	13310-Z7E-000	CRANKSHAFT COMP.	1	1	-----	SH,SH1,SHE,SM11,SWE2,SWX2,SX,SX1,SXC,SXC1,SXE,SXE1
2	13310-Z7E-800	CRANKSHAFT COMP.	1	1	-----	QA2,QBE1,QEBR,QH,QH1,QHB1,QHB3,QHB5,QHBR,QHE,QHP1,QMH,QN,QP,QX,QXBR,QXE,QXEK,QXHQ,QXK
3	13310-Z7E-810	CRANKSHAFT COMP.	1	1	-----	ES3S,ES4S,VMQ3,VPKK,VPXB,VPXE,VPXJ,VPXK,VPXX,VS4,VS6,VSB4,VTE5,VX,VX1,VX1M,VXE,VXEK,VXEM,VXK,VXKS,VXU1
	13310-ZF6-W42	1	-	-----	VPX4,VSP
4	13310-Z7E-820	CRANKSHAFT COMP.	1	1	-----	LH,LH1,LH2,LHB5,LHP1,LXE9
5	13351-Z7E-000	WEIGHT, BALANCER	1	1	-----	EDF6,EDS1,EDS2,EDT1,ES2,ES3S,ES4S,LH,LH1,LH2,LHB5,LHP1,LXE9,PX,QA2,QBE1,QEBR,QH,QH1,QHB1,QHB3,QHB5,QHBR,QHE,QHP1,QMH,QN,QP,QX,QXBR,QXE,QXEK,QXHQ,QXK,SH,SH1,SHE,SM11,SWE2,SWX2,SX,SX1,SXC,SXC1,SXE,SXE1,VMQ3,VMT3,VPKK,VPXB,VPXE,VPXJ,VPXK,VPXX,VS4,VS6,VSB4,VTE5,VX,VX1,VX1M,VXE,VXEK,VXEM,VXK,VXKS,VXU1
	13351-ZE3-010	1	-	0013664	VPX4,VSP
	13351-Z7E-000	1	-	0013665	VPX4,VSP
6	90534-706-010	WASHER, LOCK, 8.5X35X4.5	1	1	-----	SM11
7	90745-ZE2-600	KEY, 6.3X6.3X43	1	1	-----	QA2,QBE1,QEBR,QH,QH1,QHB1,QHB3,QHB5,QHBR,QHE,QHP1,QMH,QN,QP,QX,QXBR,QXE,QXEK,QXHQ,QXK
	90741-889-810	KEY, 7X7X33 (YELLOW) (O.S.) ...	(1)	(1)	-----	QHE,SH,SH1,SHE,SM11,SWE2,SWX2,SX,SX1,SXC,SXC1,SXE,SXE1
	90741-805-000	KEY, 7X7X33	1	1	-----	SH,SH1,SHE,SM11,SWE2,SWX2,SX,SX1,SXC,SXC1,SXE,SXE1
8	91001-ZF6-013	BEARING, RADIAL BALL, 6207SH	1	1	-----	
	91002-Z7E-003	BEARING, BALL RADIAL, 6207SH2	1	-	0460960	EDF6,EDS2,QHE,VPKK,VPXK,VPXX,VX1M,VXEK,VXEM,VXKS
			1	-		EDS1,EDT1,ES2,ES3S,ES4S,LH,LH1,LH2,LHB5,LHP1,LXE9,PX,QA2,QBE1,QEBR,QH,QH1,QHB1,QHB3,QHB5,QHBR,QHP1,QMH,QN,QP,QX,QXBR,QXE,QXEK,QXHQ,QXK,SH,SH1,SHE,SM11,SWE2,SWX2,SX,SX1,SXC,SXC1,SXE,SXE1,VMQ3,VMT3,VPXB,VPXE,VPXJ,VS4,VS6,VSB4,VTE5,VX,VX1,VXE,VXK,VXU1
9	92101-08025-0A	BOLT, HEX., 8X25	1	1	-----	SM11
10	13310-Z7E-700	CRANKSHAFT COMP.	1	1	-----	EDF6,EDS1,EDS2,EDT1,ES2,VMT3
11	13310-Z7E-830	CRANKSHAFT COMP.	1	1	-----	PX

E-8

PISTON

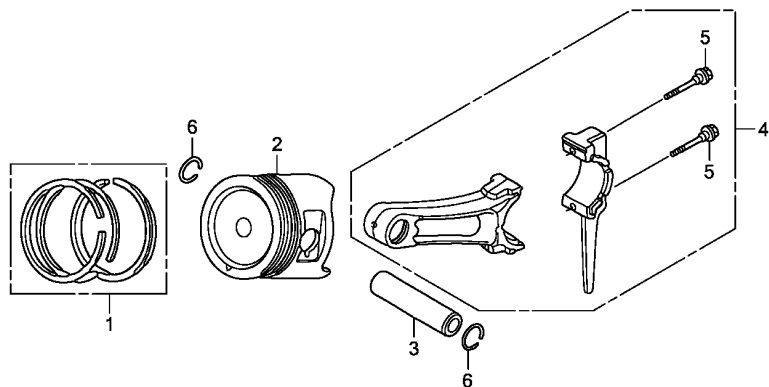

Z7E0E0800



Ref. No.	L.O.N.	(Relative ref. Number) Description	F.R.T.
2	1111R1	(1,3,4) PISTON AND/OR RING SET AND/OR BEARING AND/OR ROD	1.2

Ref. No.	Part No.	Description	Reqd. QTY		Serial No.	Parts catalogue code
			GX 390 H1	GX 390 H2		
1	13010-Z5R-004	RING SET, PISTON(STD.) (TEIKOKU)	1	-	-----	EDF6,EDS1,EDS2,EDT1,ES2,ES3S,ES4S,LH1,LH2,LHB5,LHP1,LXE9,PX,QA2,QBE1,QEBR,QH1,QHB1,QHB3,QHB5,QHBR,QHE,QHP1,QMH,QN,QP,QX,QXBR,QXE,QXEK,QXHQ,QXK,SH1,SWE2,SWX2,SX1,SXC1,SXE1,VMQ3,VMT3,VPKK,VPX4,VPXB,VPXE,VPXJ,VPXK,VPXX,VS4,VS6,VS4,VS6,VS4,VSP,VTE5,VX1,VX1M,VXE,VXEK,VXEM,VXK,VXKS,VXU1
	13011-Z5R-004	RING SET, PISTON(0.25) (TEIKOKU)	(1)	-	-----	EDF6,EDS1,EDS2,EDT1,ES2,ES3S,ES4S,LH1,LH2,LHB5,LHP1,LXE9,PX,QA2,QBE1,QEBR,QH1,QHB1,QHB3,QHB5,QHBR,QHE,QHP1,QMH,QN,QP,QX,QXBR,QXE,QXEK,QXHQ,QXK,SH1,SWE2,SWX2,SX1,SXC1,SXE1,VMQ3,VMT3,VPKK,VPX4,VPXB,VPXE,VPXJ,VPXK,VPXX,VS4,VS6,VS4,VS6,VS4,VSP,VTE5,VX1,VX1M,VXE,VXEK,VXEM,VXK,VXKS,VXU1
	13012-Z5R-004	RING SET, PISTON(0.50) (TEIKOKU)	(1)	-	-----	EDF6,EDS1,EDS2,EDT1,ES2,ES3S,ES4S,LH1,LH2,LHB5,LHP1,LXE9,PX,QA2,QBE1,QEBR,QH1,QHB1,QHB3,QHB5,QHBR,QHE,QHP1,QMH,QN,QP,QX,QXBR,QXE,QXEK,QXHQ,QXK,SH1,SWE2,SWX2,SX1,SXC1,SXE1,VMQ3,VMT3,VPKK,VPX4,VPXB,VPXE,VPXJ,VPXK,VPXX,VS4,VS6,VS4,VS6,VS4,VSP,VTE5,VX1,VX1M,VXE,VXEK,VXEM,VXK,VXKS,VXU1
	13013-Z5R-004	RING SET, PISTON(0.75) (TEIKOKU)	(1)	-	-----	EDF6,EDS1,EDS2,EDT1,ES2,ES3S,ES4S,LH1,LH2,LHB5,LHP1,LXE9,PX,QA2,QBE1,QEBR,QH1,QHB1,QHB3,QHB5,QHBR,QHE,QHP1,QMH,QN,QP,QX,QXBR,QXE,QXEK,QXHQ,QXK,SH1,SWE2,SWX2,SX1,SXC1,SXE1,VMQ3,VMT3,VPKK,VPX4,VPXB,VPXE,VPXJ,VPXK,VPXX,VS4,VS6,VS4,VS6,VS4,VSP,VTE5,VX1,VX1M,VXE,VXEK,VXEM,VXK,VXKS,VXU1
	13010-Z5T-003	RING SET, PISTON(STD.) (RIKEN)	1	-	-----	EDF6,EDS2,ES2,LH1,LH2,LHB5,LHP1,LXE9,PX,QA2,QBE1,QEBR,QH1,QHB1,QHB3,QHB5,QHBR,QHE,QHP1,QMH,QN,QP,QX,QXBR,QXE,QXEK,QXHQ,QXK,SH1,SWE2,SWX2,SX1,SXC1,SXE1,VMQ3,VMT3,VPKK,VPX4,VPXB,VPXE,VPXJ,VPXK,VPXX,VS4,VS6,VS4,VS6,VS4,VSP,VTE5,VX1,VX1M,VXE,VXEK,VXEM,VXK,VXKS,VXU1
	13011-Z5T-003	RING SET, PISTON(0.25) (RIKEN)	(1)	-	-----	EDF6,EDS2,ES2,LH1,LH2,LHB5,LHP1,LXE9,PX,QA2,QBE1,QEBR,QH1,QHB1,QHB3,QHB5,QHBR,QHE,QHP1,QMH,QN,QP,QX,QXBR,QXE,QXEK,QXHQ,QXK,SH1,SWE2,SWX2,SX1,SXC1,SXE1,VMQ3,VMT3,VPKK,VPX4,VPXB,VPXE,VPXJ,VPXK,VPXX,VS4,VS6,VS4,VS6,VS4,VSP,VTE5,VX1,VX1M,VXE,VXEK,VXEM,VXK,VXKS,VXU1



E-8

PISTON

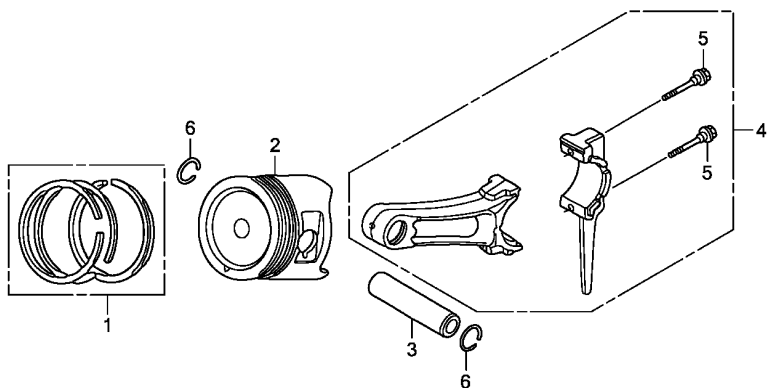

Z7E0E0800



Ref. No.	Part No.	Description	Reqd. QTY		Serial No.	Parts catalogue code
			GX 390 H1	GX 390 H2		
(1)	13012-Z5T-003	RING SET, PISTON(0.50) (RIKEN)	(1)	-	-----	EDF6,EDS2,ES2,LH1,LH2,LHB5,LHP1,LXE9,PX,QA2,QBE1,QEBR,QH1,QHB1,QHB3,QHB5,QHBR,QHE,QHP1,QMH,QN,QP,QX,QXBR,QXE,QXEK,QXHQ,QXK,SH1,SWE2,SWX2,SX1,SXC1,SXE1,VMQ3,VMT3,VPKK,VPXB,VPXE,VPXJ,VPXK,VPXX,VS4,VS6,VS4,VSP,VTE5,VX1,VX1M,VXE,VXEK,VXEM,VXK,VXKS,VXU1
	13013-Z5T-003	RING SET, PISTON(0.75) (RIKEN)	(1)	-	-----	EDF6,EDS2,ES2,LH1,LH2,LHB5,LHP1,LXE9,PX,QA2,QBE1,QEBR,QH1,QHB1,QHB3,QHB5,QHBR,QHE,QHP1,QMH,QN,QP,QX,QXBR,QXE,QXEK,QXHQ,QXK,SH1,SWE2,SWX2,SX1,SXC1,SXE1,VMQ3,VMT3,VPKK,VPXB,VPXE,VPXJ,VPXK,VPXX,VS4,VS6,VS4,VSP,VTE5,VX1,VX1M,VXE,VXEK,VXEM,VXK,VXKS,VXU1
	13010-Z7E-701	RING SET, PISTON(STD.) (FUJIAN DONGYA MACHINERY)	1	-	-----	EDS1,EDT1,ES2,LH,LH1,LH2,LHB5,LHP1,LXE9,PX,QA2,QBE1,QEBR,QH,QH1,QHB1,QHB3,QHB5,QHBR,QHP1,QMH,QN,QP,QX,QXBR,QXE,QXEK,QXHQ,QXK,SH,SH1,SHE,SM11,SWE2,SWX2,SX,SX1,SXC,SXC1,SXE,SXE1,VMQ3,VMT3,VPX4,VPXB,VPXE,VPXJ,VS4,VS6,VS4,VSP,VTE5,VX,VX1,VXE,VXK,VXU1
	13011-Z7E-701	RING SET, PISTON(0.25) (FUJIAN DONGYA MACHINERY)	(1)	-	-----	EDS1,EDT1,ES2,LH,LH1,LH2,LHB5,LHP1,LXE9,PX,QA2,QBE1,QEBR,QH,QH1,QHB1,QHB3,QHB5,QHBR,QHP1,QMH,QN,QP,QX,QXBR,QXE,QXEK,QXHQ,QXK,SH,SH1,SHE,SM11,SWE2,SWX2,SX,SX1,SXC,SXC1,SXE,SXE1,VMQ3,VMT3,VPX4,VPXB,VPXE,VPXJ,VS4,VS6,VS4,VSP,VTE5,VX,VX1,VXE,VXK,VXU1
	13012-Z7E-701	RING SET, PISTON(0.50) (FUJIAN DONGYA MACHINERY)	(1)	-	-----	EDS1,EDT1,ES2,LH,LH1,LH2,LHB5,LHP1,LXE9,PX,QA2,QBE1,QEBR,QH,QH1,QHB1,QHB3,QHB5,QHBR,QHP1,QMH,QN,QP,QX,QXBR,QXE,QXEK,QXHQ,QXK,SH,SH1,SHE,SM11,SWE2,SWX2,SX,SX1,SXC,SXC1,SXE,SXE1,VMQ3,VMT3,VPX4,VPXB,VPXE,VPXJ,VS4,VS6,VS4,VSP,VTE5,VX,VX1,VXE,VXK,VXU1
	13013-Z7E-701	RING SET, PISTON(0.75) (FUJIAN DONGYA MACHINERY)	(1)	-	-----	EDS1,EDT1,ES2,LH,LH1,LH2,LHB5,LHP1,LXE9,PX,QA2,QBE1,QEBR,QH,QH1,QHB1,QHB3,QHB5,QHBR,QHP1,QMH,QN,QP,QX,QXBR,QXE,QXEK,QXHQ,QXK,SH,SH1,SHE,SM11,SWE2,SWX2,SX,SX1,SXC,SXC1,SXE,SXE1,VMQ3,VMT3,VPX4,VPXB,VPXE,VPXJ,VS4,VS6,VS4,VSP,VTE5,VX,VX1,VXE,VXK,VXU1
	13010-ZF6-003	RING SET, PISTON(STD.) (NIPPON)	1	-	0010516	LH,QH,SH,SHE,SM11,SX,SXC,SXE,VX

E-8

PISTON

Ref. No.	Part No.	Description	Reqd. QTY		Serial No.	Parts catalogue code
			GX 390 H1	GX 390 H2		
(1)	13010-ZF6-005	RING SET, PISTON(STD.) (TEIKOKU)	1	-	-----	0010516 LH,QH,SH,SHE,SM11,SX,SXC,SXE,VX
	13011-ZF6-003	RING SET, PISTON(0.25) (NIPPON)	(1)	-	-----	0010516 LH,QH,SH,SHE,SM11,SX,SXC,SXE,VX
	13011-ZF6-005	RING SET, PISTON(0.25) (TEIKOKU)	(1)	-	-----	0010516 LH,QH,SH,SHE,SM11,SX,SXC,SXE,VX
	13012-ZF6-003	RING SET, PISTON(0.50) (NIPPON)	(1)	-	-----	0010516 LH,QH,SH,SHE,SM11,SX,SXC,SXE,VX
	13012-ZF6-005	RING SET, PISTON(0.50) (TEIKOKU)	(1)	-	-----	0010516 LH,QH,SH,SHE,SM11,SX,SXC,SXE,VX
	13013-ZF6-003	RING SET, PISTON(0.75) (NIPPON)	(1)	-	-----	0010516 LH,QH,SH,SHE,SM11,SX,SXC,SXE,VX
	13013-ZF6-005	RING SET, PISTON(0.75) (TEIKOKU)	(1)	-	-----	0010516 LH,QH,SH,SHE,SM11,SX,SXC,SXE,VX
	13010-Z5R-004	RING SET, PISTON(STD.) (TEIKOKU)	1	-	0010517 -----	LH,QH,SH,SHE,SM11,SX,SXC,SXE,VX
	13010-Z5T-003	RING SET, PISTON(STD.) (RIKEN)	1	-	0010517 -----	LH,QH,SH,SHE,SM11,SX,SXC,SXE,VX
	13011-Z5R-004	RING SET, PISTON(0.25) (TEIKOKU)	(1)	-	0010517 -----	LH,QH,SH,SHE,SM11,SX,SXC,SXE,VX
	13011-Z5T-003	RING SET, PISTON(0.25) (RIKEN)	(1)	-	0010517 -----	LH,QH,SH,SHE,SM11,SX,SXC,SXE,VX
	13012-Z5R-004	RING SET, PISTON(0.50) (TEIKOKU)	(1)	-	0010517 -----	LH,QH,SH,SHE,SM11,SX,SXC,SXE,VX
	13012-Z5T-003	RING SET, PISTON(0.50) (RIKEN)	(1)	-	0010517 -----	LH,QH,SH,SHE,SM11,SX,SXC,SXE,VX
	13013-Z5R-004	RING SET, PISTON(0.75) (TEIKOKU)	(1)	-	0010517 -----	LH,QH,SH,SHE,SM11,SX,SXC,SXE,VX
	13013-Z5T-003	RING SET, PISTON(0.75) (RIKEN)	(1)	-	0010517 -----	LH,QH,SH,SHE,SM11,SX,SXC,SXE,VX
	13010-Z5T-003	RING SET, PISTON(STD.) (RIKEN)	1	-	0010616 -----	VPX4
	13011-Z5T-003	RING SET, PISTON(0.25) (RIKEN)	(1)	-	0010616 -----	VPX4
	13012-Z5T-003	RING SET, PISTON(0.50) (RIKEN)	(1)	-	0010616 -----	VPX4
	13013-Z5T-003	RING SET, PISTON(0.75) (RIKEN)	(1)	-	0010616 -----	VPX4
	13010-Z7E-931	RING SET, PISTON(STD.) (TPR)	-	-	1	
	13011-Z7E-931	RING SET, PISTON(0.25) (TPR)	-	-	(1)	
	13012-Z7E-931	RING SET, PISTON(0.50) (TPR)	-	-	(1)	
	13013-Z7E-931	RING SET, PISTON(0.75) (TPR)	-	-	(1)	
2	13101-Z7E-800	PISTON(STD.)	1	-	-----	EDF6,EDS1,EDS2,EDT1,ES2,ES3S,ES4S,LH1,LH2,LHB5,LHP1,LXE9,PX,QA2,QBE1 QEBR,QH1,QHB1,QHB3,QHB5,QHBR,QHE,QHP1,QMH,QN,QP,QX,QXBR,QXE,QXEK,QXHQ QXK,SH1,SWE2,SWX2, SX1, SXC1, SXE1,VMQ3,VMT3,VPKK,VPXB,VPXE,VPXJ,VPXK VPXX,VS4,VS6, VSB4, VTE5, VX1, VX1M, VXE, VXEK, VDEM, VVK, VVKS, VXU1
	13102-Z7E-800	PISTON(0.25)	(1)	-	-----	EDF6,EDS1,EDS2,EDT1,ES2,ES3S,ES4S,LH1,LH2,LHB5,LHP1,LXE9,PX,QA2,QBE1 QEBR,QH1,QHB1,QHB3,QHB5,QHBR,QHE,QHP1,QMH,QN,QP,QX,QXBR,QXE,QXEK,QXHQ QXK,SH1,SWE2,SWX2, SX1, SXC1, SXE1,VMQ3,VMT3,VPKK,VPXB,VPXE,VPXJ,VPXK VPXX,VS4,VS6, VSB4, VTE5, VX1, VX1M, VXE, VXEK, VDEM, VVK, VVKS, VXU1
	13103-Z7E-800	PISTON(0.50)	(1)	-	-----	EDF6,EDS1,EDS2,EDT1,ES2,ES3S,ES4S,LH1,LH2,LHB5,LHP1,LXE9,PX,QA2,QBE1 QEBR,QH1,QHB1,QHB3,QHB5,QHBR,QHE,QHP1,QMH,QN,QP,QX,QXBR,QXE,QXEK,QXHQ QXK,SH1,SWE2,SWX2, SX1, SXC1, SXE1,VMQ3,VMT3,VPKK,VPXB,VPXE,VPXJ,VPXK VPXX,VS4,VS6, VSB4, VTE5, VX1, VX1M, VXE, VXEK, VDEM, VVK, VVKS, VXU1
	13104-Z7E-800	PISTON(0.75)	(1)	-	-----	EDF6,EDS1,EDS2,EDT1,ES2,ES3S,ES4S,LH1,LH2,LHB5,LHP1,LXE9,PX,QA2,QBE1 QEBR,QH1,QHB1,QHB3,QHB5,QHBR,QHE,QHP1,QMH,QN,QP,QX,QXBR,QXE,QXEK,QXHQ QXK,SH1,SWE2,SWX2, SX1, SXC1, SXE1,VMQ3,VMT3,VPKK,VPXB,VPXE,VPXJ,VPXK VPXX,VS4,VS6, VSB4, VTE5, VX1, VX1M, VXE, VXEK, VDEM, VVK, VVKS, VXU1
	13101-Z5T-000	PISTON(STD.)	1	-	-----	VSP
	13102-Z5T-000	PISTON(0.25)	(1)	-	-----	VSP
	13103-Z5T-000	PISTON(0.50)	(1)	-	-----	VSP
	13104-Z5T-000	PISTON(0.75)	(1)	-	-----	VSP
	13101-ZF6-W00	PISTON(STD.)	1	-	0010516 -----	LH,QH,SH,SHE,SM11,SX,SXC,SXE,VX
	13102-ZF6-W00	PISTON(0.25)	(1)	-	0010516 -----	LH,QH,SH,SHE,SM11,SX,SXC,SXE,VX
	13103-ZF6-W00	PISTON(0.50)	(1)	-	0010516 -----	LH,QH,SH,SHE,SM11,SX,SXC,SXE,VX
	13104-ZF6-W00	PISTON(0.75)	(1)	-	0010516 -----	LH,QH,SH,SHE,SM11,SX,SXC,SXE,VX
	13101-ZF6-W01	PISTON(STD.)	1	-	0022196 -----	VPX4,VSP
	13102-ZF6-W01	PISTON(0.25)	(1)	-	0022196 -----	VPX4,VSP
	13103-ZF6-W01	PISTON(0.50)	(1)	-	0022196 -----	VPX4,VSP



E-8

PISTON

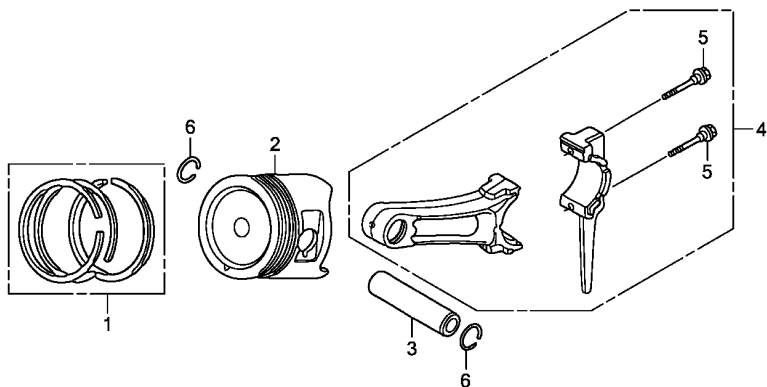

Z7E0E0800



Ref. No.	Part No.	Description	Reqd. QTY		Serial No.	Parts catalogue code
			GX 390 H1	GX 390 H2		
(2)	13104-ZF6-W01	PISTON(0.75)	(1)	-	0022196	VPX4,VSP
	13101-ZF6-W01	PISTON(STD.)	1	-	0010517	0022196 LH,QH,SH,SHE,SM11,SX,SXC,SXE,VX
	13102-ZF6-W01	PISTON(0.25)	(1)	-	0010517	0022196 LH,QH,SH,SHE,SM11,SX,SXC,SXE,VX
	13103-ZF6-W01	PISTON(0.50)	(1)	-	0010517	0022196 LH,QH,SH,SHE,SM11,SX,SXC,SXE,VX
	13104-ZF6-W01	PISTON(0.75)	(1)	-	0010517	0022196 LH,QH,SH,SHE,SM11,SX,SXC,SXE,VX
	13101-Z7E-800	PISTON(STD.)	1	-	0022197	----- LH,QH,SH,SHE,SM11,SX,SXC,SXE,VPX4,VSP,VX
	13102-Z7E-800	PISTON(0.25)	(1)	-	0022197	----- LH,QH,SH,SHE,SM11,SX,SXC,SXE,VPX4,VSP,VX
	13103-Z7E-800	PISTON(0.50)	(1)	-	0022197	----- LH,QH,SH,SHE,SM11,SX,SXC,SXE,VPX4,VSP,VX
	13104-Z7E-800	PISTON(0.75)	(1)	-	0022197	----- LH,QH,SH,SHE,SM11,SX,SXC,SXE,VPX4,VSP,VX
	13101-Z7E-930	PISTON(STD.)	-	1		
	13102-Z7E-930	PISTON(0.25)	-	(1)		
	13103-Z7E-930	PISTON(0.50)	-	(1)		
	13104-Z7E-930	PISTON(0.75)	-	(1)		
3	13111-Z7E-000	PIN, PISTON	1	-	-----	EDF6,EDS1,EDS2,EDT1,ES2,ES3S,ES4S,LH,LH1,LH2,LHB5,LHP1,LXE9,PX,QA2,QBE1,QEBR,QH,QH1,QHB1,QHB3,QHB5,QHBR,QHE,QHP1,QMH,QN,QP,QX,QXBR,QXE,QXEK,QXHQ,QXK,SH,SH1,SHE,SM11,SWE2,SWX2,SX,SX1,SXC,SXC1,SXE,SXE1,VMQ3,VMT3,VPKK,VPXB,VPXE,VPXJ,VPXK,VPXX,VS4,VS6,VS4,VS6,VS4,VTE5,VX,VX1,VX1M,VXE,VXEK,VXEM,VXK,VXKS,VXU1
	13111-ZF6-W00	-----	1	-	0001148	VPX4,VSP
	13111-Z7E-000	-----	1	-	0001149	VPX4,VSP
	13111-Z5T-000	-----	-	1		
4	13200-Z1C-305	ROD ASSY., CONNECTING (0.25 UNDER SIZE)	(1)	-	-----	EDF6,EDS1,EDS2,EDT1,VSP
	13200-Z7E-000	ROD ASSY., CONNECTING(JLH) (IDENT MARK Z)	1	-	-----	EDF6,EDS2,ES2,LH1,LH2,LHB5,LHP1,LXE9,PX,QBE1,QEBR,QH1,QHB1,QHB3,QHB5,QHBR,QHE,QHP1,QMH,QN,QP,QX,QXBR,QXE,QXEK,QXK,SH1,SWE2,SWX2,SX1,SXC1,SXE1,VMQ3,VMT3,VPKK,VPXJ,VPXK,VPXX,VS4,VS6,VS4,VTE5,VX1,VX1M,VXE,VXEK,VXEM,VXK,VXKS,VXU1

E-8

PISTON

Ref. No.	Part No.	Description	Reqd. QTY		Serial No.	Parts catalogue code
			GX 390 H1	GX 390 H2		
(4)	13200-Z1C-000	ROD ASSY., CONNECTING(STD.) -	1	-	-----	EDS1,EDS2,EDT1,ES3S,ES4S,QH,QXHQ,SH,SM11,SX,VPXB,VPXE,VSP,VX,VXEK,VXKS
	13200-ZE3-315	ROD ASSY., CONNECTING (0.25 UNDER SIZE)	(1)	-	-----	ES2,ES3S,ES4S,LH,QA2,QH,QHE,QXHQ,SH,SHE,SM11,SX,SXC,SXE,VMQ3,VMT3,VPKK,VPX4,VPXB,VPXE,VPXJ,VPXK,VPXX,VS4,VS6,USB4,VX,VXEK,VXKS
	13200-Z7E-305	ROD ASSY., CONNECTING(JLH) (0.25 UNDER SIZE)	(1)	-	-----	ES2,LH1,LH2,LHB5,LHP1,LXE9,PX,QBE1,QEBR,QH1,QHB1,QHB3,QHB5,QHBR,QHP1,QMH,QN,QP,QX,QXBR,QXE,QXEK,QXK,SH1,SWE2,SWX2,SX1,SXC1,SXE1,VMQ3,VMT3,VS4,VS6,USB4,VTE5,VX1,VX1M,VXE,VXEM,VXK,VXU1
	13200-ZE3-020	ROD ASSY., CONNECTING(STD.) -	1	-	-----	QA2
	13200-Z1C-000	1	-	0029325	VPX4
	13200-Z1C-000	1	-	0139755	LH,SHE,SXC,SXE
	13200-Z7E-000	ROD ASSY., CONNECTING(JLH) (IDENT MARK Z)	1	-	0029326	VPX4
	13200-Z1C-000	ROD ASSY., CONNECTING(STD.) -	-	1	-----	
	13200-Z1C-305	ROD ASSY., CONNECTING (0.25 UNDER SIZE)	-	(1)	-----	
	13200-Z7E-000	ROD ASSY., CONNECTING(JLH) (IDENT MARK Z)	-	1	-----	
5	90001-Z7E-000	BOLT, CONNECTING ROD(FOR JLH)	2	-	-----	EDF6,EDS2,ES2,LH1,LH2,LHB5,LHP1,LXE9,PX,QBE1,QEBR,QH1,QHB1,QHB3,QHB5,QHBR,QHE,QHP1,QMH,QN,QP,QX,QXBR,QXE,QXEK,QXK,SH1,SWE2,SWX2,SX1,SXC1,SXE1,VMQ3,VMT3,VPKK,VPXJ,VPXK,VPXX,VS4,VS6,USB4,VTE5,VX1,VX1M,VXE,VXEK,VXEM,VXK,VXKS,VXU1
	90001-ZE8-000	BOLT, CONNECTING ROD	2	-	-----	EDS1,EDS2,EDT1,ES3S,ES4S,QA2,QH,QXHQ,SH,SM11,SX,VPX4,VPXB,VPXE,VSP,VX,VXEK,VXKS
	90001-Z7E-000	BOLT, CONNECTING ROD(FOR JLH)	2	-	0139755	LH,SHE,SXC,SXE
	90001-Z7E-000	BOLT, CONNECTING ROD(FOR JLH)	2	-	0139756	LH,SHE,SXC,SXE
	90001-Z7E-000	BOLT, CONNECTING ROD(FOR JLH)	2	-	0373907	EDS1,EDT1,ES3S,ES4S,QA2,QH,QXHQ,SH,SM11,SX,VPX4,VPXB,VPXE,VSP,VX
	90001-ZE8-000	BOLT, CONNECTING ROD	-	2	-----	
6	90601-ZE3-000	CLIP, PISTON PIN, 20MM	2	2	-----	



E-9

CAMSHAFT

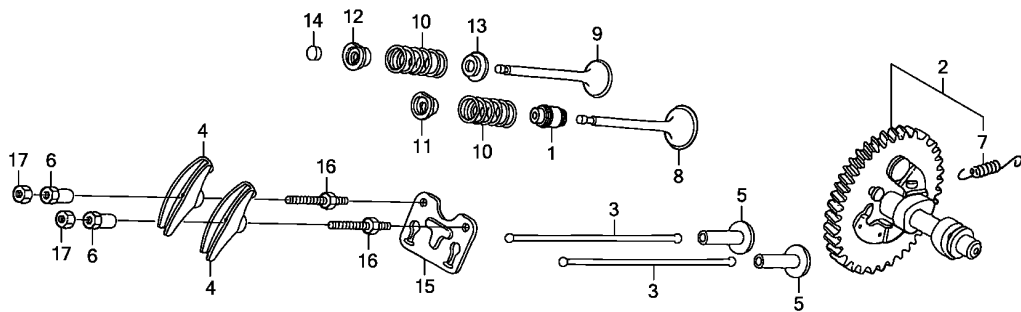

Z7E0E0900



Ref. No.	L.O.N.	(Relative ref. Number) Description	F.R.T.
1	1111K2	SEAL, INTAKE VALVE STEMINCLUDES: Valve clearance adjustment	0.6
2	1111C2	CAMSHAFTINCLUDES: Valve clearance adjustment	0.4
3	1111L6	ROD, PUSH :INTAKEINCLUDES: Valve clearance adjustment	0.2
	1111L6A	.Replace exhaust push rod add	0.1
	1111L7	ROD, PUSH :EXHAUSTINCLUDES: Valve clearance adjustment	0.2
	1111L7A	.Replace intake push rod add	0.1
4	1111A2	ARM, ROCKER :INTAKEINCLUDES: Valve clearance adjustment	0.2
	1111A2A	.Replace exhaust rocker arm add	0.1
	1111A1	ARM, ROCKER :EXHAUSTINCLUDES: Valve clearance adjustment	0.2
	1111A1A	.Replace intake rocker arm add	0.1
+ 5	1111L9	LIFTER, VALVE :INTAKE	0.4

Ref. No.	Part No.	Description	Reqd. QTY		Serial No.	Parts catalogue code
			GX 390 H1	GX 390 H2		
1	12209-Z7E-003	SEAL, VALVE STEM	1	-	-----	EDF6,EDS2,ES2,ES3S,ES4S,LH,LH1,LH2,LHB5,LHP1,LXE9,PX,QA2,QBE1,QEBR,QH QH1,QHB1,QHB3,QHB5,QHBR,QHE,QHP1,QMH,QN,QP,QX,QXBR,QXE,QXEK,QXHQ,QXK SH,SH1,SHE,SM11,SWE2,SWX2,SX,SX1,SXC,SXC1,SXE,SXE1,VMQ3,VMT3,VPKK VPXB,VPXE,VPXJ,VPXK,VPXX,VS4,VS6,VS4,VS6,VS4,VTE5,VX,VX1,VX1M,VXE,VXEK,VXEM VXX,VXKS,VXU1
	12209-ZE8-003	1	-	0000128	EDS1,EDT1
	12209-Z7E-003	1	-	0001148	VPX4,VSP
			1	-	0000129	EDS1,EDT1
			1	-	0001149	VPX4,VSP
			-	1		
2	14100-ZF6-W01	CAMSHAFT ASSY.	1	-	-----	
	14100-Z7E-930	-	1		
3	14410-Z7E-000	ROD, PUSH	2	-	-----	EDF6,EDS2,ES2,ES3S,ES4S,LH,LH1,LH2,LHB5,LHP1,LXE9,PX,QA2,QBE1,QEBR,QH QH1,QHB1,QHB3,QHB5,QHBR,QHE,QHP1,QMH,QN,QP,QX,QXBR,QXE,QXEK,QXHQ,QXK SH,SH1,SHE,SM11,SWE2,SWX2,SX,SX1,SXC,SXC1,SXE,SXE1,VMQ3,VMT3,VPKK VPXB,VPXE,VPXJ,VPXK,VPXX,VS4,VS6,VS4,VS6,VS4,VTE5,VX,VX1,VX1M,VXE,VXEK,VXEM VXX,VXKS,VXU1
	14410-ZE3-013	2	-	0000128	EDS1,EDT1,VPX4
	14410-Z1C-000	2	-	0000128	VSP
	14410-Z7E-000	2	-	0000129	EDS1,EDT1,VPX4,VSP
			-	2		
4	14431-ZE2-010	ARM, VALVE ROCKER	2	2	-----	
5	14441-Z7E-000	LIFTER, VALVE	2	-	-----	EDF6,EDS2,ES2,ES3S,ES4S,LH,LH1,LH2,LHB5,LHP1,LXE9,PX,QA2,QBE1,QEBR,QH QH1,QHB1,QHB3,QHB5,QHBR,QHE,QHP1,QMH,QN,QP,QX,QXBR,QXE,QXEK,QXHQ,QXK SH,SH1,SHE,SM11,SWE2,SWX2,SX,SX1,SXC,SXC1,SXE,SXE1,VMQ3,VMT3,VPKK VPXB,VPXE,VPXJ,VPXK,VPXX,VS4,VS6,VS4,VS6,VS4,VTE5,VX,VX1,VX1M,VXE,VXEK,VXEM VXX,VXKS,VXU1
	14441-ZE2-000	2	-	0000128	EDS1,EDT1,VPX4,VSP

E-9

CAMSHAFT

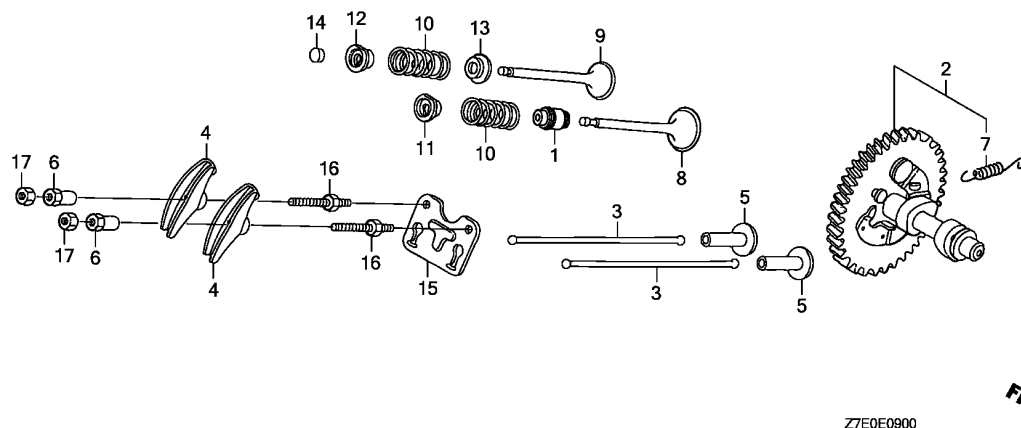

Ref. No.	L.O.N.	(Relative ref. Number) Description	F.R.T.
+ 5		.INCLUDES: Valve clearance adjustment	
1111M0		.NOTE: Same time for two units LIFTER, VALVE :EXHAUST	0.4
8	1111L1	.INCLUDES: Valve clearance adjustment .NOTE: Same time for two units VALVE, INTAKE	0.7
1111L1E		.INCLUDES: Valve clearance adjustment and reface .Replace intake and exhaust all add	0.2
9	1111L0	VALVE, EXHAUST	0.7
1111L0E		.INCLUDES: Valve clearance adjustment and reface .Replace intake and exhaust all add	0.2
10	1111P3	SPRING, VALVE :INTAKE	0.6
1111P3A		.INCLUDES: Valve clearance adjustment .Replace intake and exhaust all add	0.1
1111P4		SPRING, VALVE :EXHAUST	0.6
+		.INCLUDES: Valve clearance adjustment	

Ref. No.	Part No.	Description	Reqd. QTY		Serial No.	Parts catalogue code
			GX 390 H1	GX 390 H2		
(5)	14441-Z7E-000	LIFTER, VALVE	2	-	0000129	----- EDS1,EDT1,VPX4,VSP
			-	2		
6	14451-Z7E-000	PIVOT, ROCKER ARM	2	2		
7	14568-ZE1-000	SPRING, WEIGHT RETURN	1	1		
8	14711-Z7E-000	VALVE, IN.	1	-	-----	----- EDF6,EDS2,ES2,LH,LH1,LH2,LHB5,LHP1,LXE9,PX,QA2,QBE1,QEBR,QH,QH1,QHB1,QHB3,QHB5,QHBR,QHE,QHP1,QMH,QN,QP,QX,QXBR,QXE,QXEK,QXHQ,QXK,SH,SH1,SHE,SM11,SWE2,SWX2,SX,SX1,SXC,SXC1,SXE,SXE1,VMQ3,VMT3,VPKK,VPXB,VPXE,VPXJ,VPXK,VPXX,VTE5,VX,VX1,VX1M,VXE,VXEM,VXK,VXKS,VXU1
	14711-ZE3-000	1	-	-----	0000128 EDS1,EDT1,VPX4,VSP
			1	-	-----	0658884 ES3S,ES4S
	14711-Z7E-000	1	-	0000129	----- EDS1,EDT1,VPX4,VSP
			1	-	0658885	----- ES3S,ES4S
	14711-Z5T-900	-	1		
9	14721-Z7E-800	VALVE, EX. (STELLITE)	1	-	-----	----- EDF6,EDS2,ES2,VMQ3,VMT3,VS4,VS6,VS4,VXEK,VXKS
	14721-Z7E-000	VALVE, EX.	1	-	-----	----- LH,LH1,LH2,LHB5,LHP1,LXE9,PX,QA2,QBE1,QEBR,QH,QH1,QHB1,QHB3,QHB5,QHBR,QHE,QHP1,QMH,QN,QP,QX,QXBR,QXE,QXEK,QXHQ,QXK,SH,SH1,SHE,SM11,SWE2,SWX2,SX,SX1,SXC,SXC1,SXE,SXE1,VPKK,VPXB,VPXE,VPXJ,VPXK,VPXX,VTE5,VX,VX1,VX1M,VXE,VXEM,VXK,VXU1
	14721-ZE3-000	1	-	0000128	VPX4,VSP
	14721-ZE3-810	VALVE, EX. (STELLITE)	1	-	0002756	EDS1,EDT1
			1	-	0659972	ES3S,ES4S
	14721-Z7E-000	VALVE, EX.	1	-	0000129	VPX4,VSP
	14721-Z7E-800	VALVE, EX. (STELLITE)	1	-	0002757	EDS1,EDT1
			1	-	0659973	ES3S,ES4S
	14721-Z5T-800	-	1	-----	----- EDS1,EDS2,EDT1,ES2,VXEK,VXKS
	14721-Z5T-900	VALVE, EX.	-	1	-----	----- LH,LH1,PX,QH,QH1,QHE,QMH,QN,QX,QXE,QXHQ,SH,SH1,SHE,SM11,SWX2,SX,SX1,SXC,SXC1,VPKK,VPXB,VPXE,VPXK,VPXX,VTE5,VX,VX1,VX1M,VXE,VXEM



E-9

CAMSHAFT

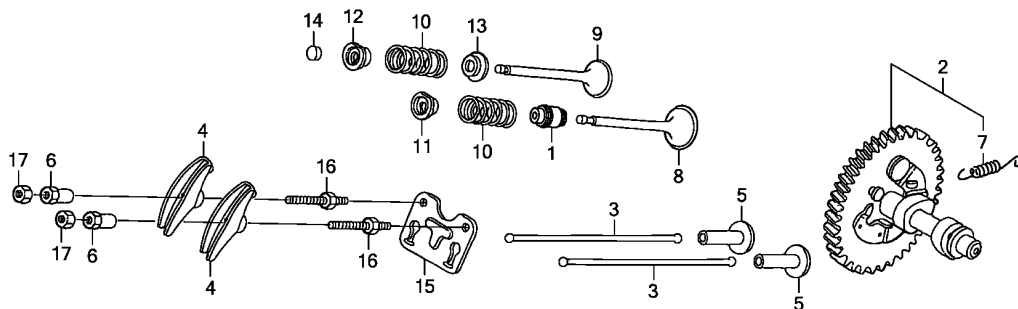

Z7E0E0900

Ref. No.	L.O.N.	(Relative ref. Number) Description	F.R.T.
+10	1111P4A	.Replace intake and exhaust all add	0.1
14	1111J7	ROTATOR, VALVE	0.2
		.INCLUDES: Valve clearance adjustment	

Ref. No.	Part No.	Description	Reqd. QTY		Serial No.	Parts catalogue code
			GX 390 H1	GX 390 H2		
10	14751-Z7E-000	SPRING, VALVE	2	-	-----	EDF6,EDS2,ES2,ES3S,ES4S,LH,LH1,LH2,LHB5,LHP1,LXE9,PX,QA2,QBE1,QEBR,QH,QH1,QHB1,QHB3,QHB5,QHBR,QHE,QHP1,QMH,QN,QP,QX,QXBR,QXE,QXEK,QXHQ,QXK,SH,SH1,SHE,SM11,SWE2,SWX2,SX,SX1,SXC,SXC1,SXE,SXE1,VMQ3,VMT3,VPKK,VPXB,VPXE,VPXJ,VPXK,VPXX,VS4,VS6,VS4,VS6,VS4,VTE5,VX,VX1,VX1M,VXE,VXEK,VXEM,VXK,VXKS,VXU1
	14751-ZE2-003	2	-	0000128	EDS1,EDT1,VPX4
	14751-Z1C-000	2	-	0000128	VSP
	14751-Z7E-000	2	-	0000129	EDS1,EDT1,VPX4,VSP
			-	2		
11	14771-ZE2-000	RETAINER, IN. VALVE SPRING ..	1	1		
12	14773-ZE2-000	RETAINER, EX. VALVE SPRING ..	1	-		
	14771-ZE2-000	RETAINER, IN. VALVE SPRING .. (EXHAUST SIDE)	-	1		
13	14775-ZE2-010	SEAT, VALVE SPRING	1	1		
14	14781-Z7E-000	ROTATOR, VALVE	1	-	-----	ES2,ES3S,ES4S,LH,LH1,LH2,LHB5,LHP1,LXE9,PX,QA2,QBE1,QEBR,QH,QH1,QHB1,QHB3,QHB5,QHBR,QHE,QHP1,QMH,QN,QP,QX,QXBR,QXE,QXEK,QXHQ,QXK,SH,SH1,SHE,SM11,SWE2,SWX2,SX,SX1,SXC,SXC1,SXE,SXE1,VMQ3,VMT3,VPKK,VPXB,VPXE,VPXJ,VPXK,VPXX,VS4,VS6,VS4,VS6,VS4,VTE5,VX,VX1,VX1M,VXE,VXEK,VXEM,VXK,VXKS,VXU1
	14781-ZE2-000	1	-	0001508	EDS1,EDT1,VPX4,VSP
	14781-Z7E-000	1	-	0001509	EDS1,EDT1,VPX4,VSP
15	14791-Z7E-000	GUIDE, PUSH ROD	1	-	-----	EDF6,EDS2,ES2,LH,LH1,LH2,LHB5,LHP1,LXE9,PX,QA2,QBE1,QEBR,QH,QH1,QHB1,QHB3,QHB5,QHBR,QHE,QHP1,QMH,QN,QP,QX,QXBR,QXE,QXEK,QXHQ,QXK,SH,SH1,SHE,SM11,SWE2,SWX2,SX,SX1,SXC,SXC1,SXE,SXE1,VMQ3,VMT3,VPKK,VPXB,VPXE,VPXJ,VPXK,VPXX,VS4,VS6,VS4,VS6,VS4,VTE5,VX,VX1,VX1M,VXE,VXEK,VXEM,VXK,VXKS,VXU1
	14791-ZE2-010	1	-	-----	ES3S,ES4S
			1	-	0001616	EDS1,EDT1,VPX4,VSP

E-9

CAMSHAFT

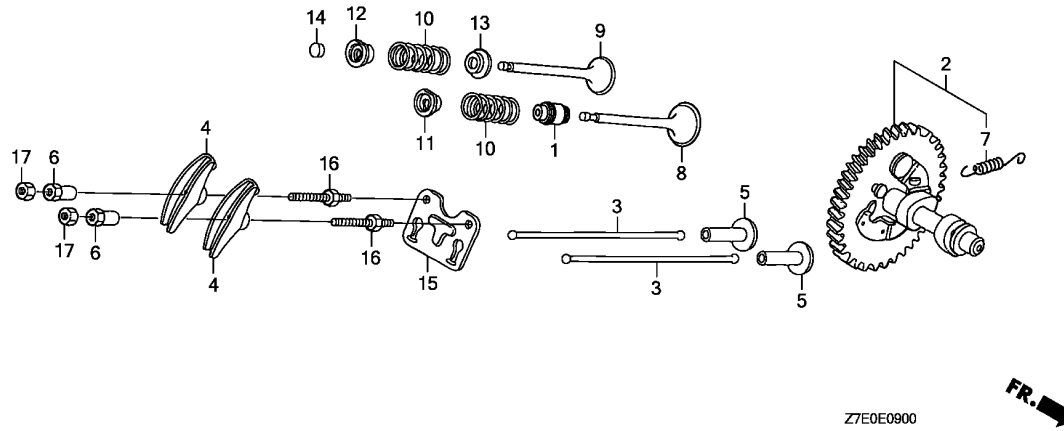

Ref. No.	Part No.	Description	Reqd. QTY		Serial No.	Parts catalogue code
			GX 390 H1	GX 390 H2		
15)	14791-Z7E-000	GUIDE, PUSH ROD	1	-	0001617 -----	EDS1,EDT1,VPX4,VSP
			-	1		
	16	90012-ZE0-010 BOLT, PIVOT, 8MM	2	2		
	17	90206-ZE1-000 NUT, PIVOT ADJUSTING	2	2		

E-11

RECOIL STARTER(1)

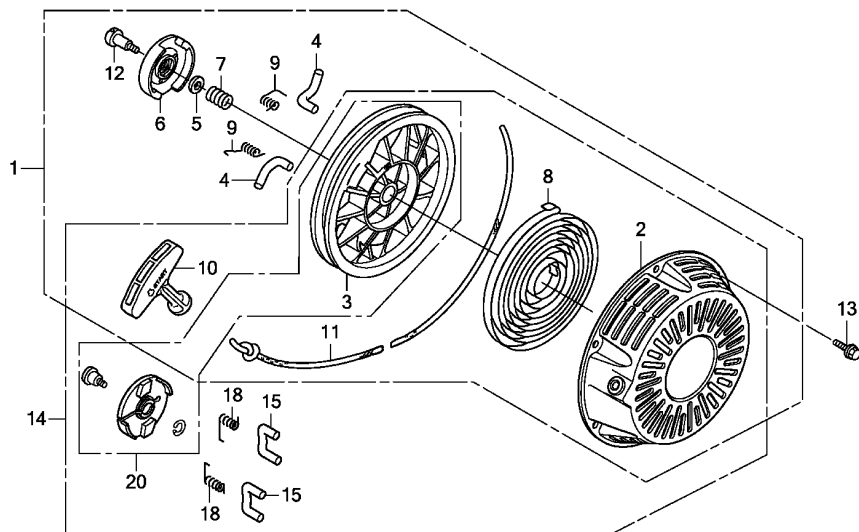

Ref. No.	L.O.N.	(Relative ref. Number) Description	F.R.T.
1		(14)	
1121B9		STARTER, RECOIL	0.1
3		(20)	
1121B1		REEL, RECOIL STARTER	0.3
4		(9,15,18)	
1121B0		STARTER RATCHET AND/OR SPRING	0.2
6		(7)	
1121A4		GUIDE, RATCHET	0.2
8		1121B7 SPRING, RECOIL STARTER RETURN	0.3
10		1121A3 GRIP, RECOIL STARTER	0.1
11		1121B3 ROPE, RECOIL STARTER	0.3

FR. →
Z7E0E1100B

Ref. No.	Part No.	Description	Reqd. QTY		Serial No.	Parts catalogue code
			GX 390 H1	GX 390 H2		
1	28400-Z7E-003ZB	STARTER ASSY., RECOIL *R280*.....POWER RED	1	-	0281238	EDS1,EDT1,ES2,LH,LH1,LH2,LHB5,LHP1,LXE9,PX,QA2,QBE1,QH,QH1,QHB1,QHB3,QHB5,QHP1,QMH,QN,QP,QX,QXE,QXEK,QXHQ,QXK,SH,SH1,SHE,SM11,SWE2,SWX2,SX,SX1,SXC,SXC1,SXE,SXE1,VMQ3,VMT3,VPXB,VPXE,VS4,VS6,VS4,VS6,VS4,VTE5,VX,VX1,VXE,VXK,VXU1
	28400-Z7E-003ZA	*NH1*.....BLACK	1	-	0281238	QXHQ,SX
	28400-Z7E-003ZB	*R280*.....POWER RED	1	-	0001867	0281238 VPX4,VSP
2	28410-Z7E-003ZB	CASE COMP., RECOIL STARTER *R280*.....POWER RED	1	-	0281238	EDS1,EDT1,ES2,LH,LH1,LH2,LHB5,LHP1,LXE9,PX,QA2,QBE1,QH,QH1,QHB1,QHB3,QHB5,QHP1,QMH,QN,QP,QX,QXE,QXEK,QXHQ,QXK,SH,SH1,SHE,SM11,SWE2,SWX2,SX,SX1,SXC,SXC1,SXE,SXE1,VMQ3,VMT3,VPXB,VPXE,VS4,VS6,VS4,VS6,VS4,VTE5,VX,VX1,VXE,VXK,VXU1
	28410-Z7E-003ZA	*NH1*.....BLACK	1	-	0281238	QXHQ,SX
	28410-Z7E-701ZA	*R280*.....POWER RED	1	-	0386426	QEBR,QHBR,QXBR,VPXJ
	28410-Z7E-003ZB	*R280*.....POWER RED	1	-	0001867	0281238 VPX4,VSP
	28410-Z7E-701ZA	*R280*.....POWER RED	1	-	0281239	0386426 EDS1,EDT1,ES2,LH,LH1,LH2,LHB5,LHP1,LXE9,PX,QA2,QBE1,QH,QH1,QHB1,QHB3,QHB5,QHP1,QMH,QN,QP,QX,QXE,QXEK,QXHQ,QXK,SH,SH1,SHE,SM11,SWE2,SWX2,SX,SX1,SXC,SXC1,SXE,SXE1,VMQ3,VMT3,VPXB,VPXE,VS4,VS6,VS4,VS6,VS4,VSP,VTE5,VX,VX1,VXE,VXK,VXU1
	28410-Z7E-701ZB	*NH1*.....BLACK	1	-	0281239	0386426 EDS1,EDT1,QXHQ,SX,VSP
3	28420-Z7E-003	REEL, RECOIL STARTER	1	-	0281238	EDS1,EDT1,ES2,LH,LH1,LH2,LHB5,LHP1,LXE9,PX,QA2,QBE1,QH,QH1,QHB1,QHB3,QHB5,QHP1,QMH,QN,QP,QX,QXE,QXEK,QXHQ,QXK,SH,SH1,SHE,SM11,SWE2,SWX2,SX,SX1,SXC,SXC1,SXE,SXE1,VMQ3,VMT3,VPXB,VPXE,VS4,VS6,VS4,VS6,VS4,VTE5,VX,VX1,VXE,VXK,VXU1
			1	-	0001867	0281238 VPX4,VSP

E-11

RECOIL STARTER(1)

Ref. No.	Part No.	Description	Reqd. QTY		Serial No.	Parts catalogue code
			GX 390 H1	GX 390 H2		
4	28422-ZH8-801	RATCHET, STARTER	2	-	0281238	EDS1,EDT1,ES2,LH,LH1,LH2,LHB5,LHP1,LXE9,PX,QA2,QBE1,QH,QH1,QHB1,QHB3,QHB5,QHP1,QMH,QN,QP,QX,QXE,QXEK,QXHQ,QXK,SH,SH1,SHE,SM11,SWE2,SWX2,SX,SX1,SXC,SXC1,SXE,SXE1,VMQ3,VMT3,VPXB,VPXE,VS4,VS6,VS4,VTE5,VX,VX1,VXE,VXK,VXU1
5	28431-ZH8-801	PLATE, FRICTION	2	-	0001867	0281238 VPX4,VSP
			1	-	0281238	EDS1,EDT1,ES2,LH,LH1,LH2,LHB5,LHP1,LXE9,PX,QA2,QBE1,QH,QH1,QHB1,QHB3,QHB5,QHP1,QMH,QN,QP,QX,QXE,QXEK,QXHQ,QXK,SH,SH1,SHE,SM11,SWE2,SWX2,SX,SX1,SXC,SXC1,SXE,SXE1,VMQ3,VMT3,VPXB,VPXE,VS4,VS6,VS4,VTE5,VX,VX1,VXE,VXK,VXU1
			1	-	0001867	0281238 VPX4,VSP
6	28433-Z2E-003	GUIDE, RATCHET	1	-	0281238	EDS1,EDT1,ES2,LH,LH1,LH2,LHB5,LHP1,LXE9,PX,QA2,QBE1,QH,QH1,QHB1,QHB3,QHB5,QHP1,QMH,QN,QP,QX,QXE,QXEK,QXHQ,QXK,SH,SH1,SHE,SM11,SWE2,SWX2,SX,SX1,SXC,SXC1,SXE,SXE1,VMQ3,VMT3,VPXB,VPXE,VS4,VS6,VS4,VTE5,VX,VX1,VXE,VXK,VXU1
			1	-	0001867	0281238 VPX4,VSP
7	28441-Z2E-003	SPRING, FRICTION	1	-	0281238	EDS1,EDT1,ES2,LH,LH1,LH2,LHB5,LHP1,LXE9,PX,QA2,QBE1,QH,QH1,QHB1,QHB3,QHB5,QHP1,QMH,QN,QP,QX,QXE,QXEK,QXHQ,QXK,SH,SH1,SHE,SM11,SWE2,SWX2,SX,SX1,SXC,SXC1,SXE,SXE1,VMQ3,VMT3,VPXB,VPXE,VS4,VS6,VS4,VTE5,VX,VX1,VXE,VXK,VXU1
			1	-	0001867	0281238 VPX4,VSP
8	28442-Z7E-003	SPRING, RECOIL STARTER	1	-	0386426	EDS1,EDT1,ES2,LH,LH1,LH2,LHB5,LHP1,LXE9,PX,QA2,QBE1,QEBR,QH,QH1,QHB1,QHB3,QHB5,QHBR,QHP1,QMH,QN,QP,QX,QXBR,QXE,QXEK,QXHQ,QXK,SH,SH1,SHE,SM11,SWE2,SWX2,SX,SX1,SXC,SXC1,SXE,SXE1,VMQ3,VMT3,VPXB,VPXE,VPXJ,VS4,VS6,VS4,VTE5,VX,VX1,VXE,VXK,VXU1
			1	-	0001867	0386426 VPX4,VSP
9	28443-ZH8-801	SPRING, RETURN	2	-	0281238	EDS1,EDT1,ES2,LH,LH1,LH2,LHB5,LHP1,LXE9,PX,QA2,QBE1,QH,QH1,QHB1,QHB3,QHB5,QHP1,QMH,QN,QP,QX,QXE,QXEK,QXHQ,QXK,SH,SH1,SHE,SM11,SWE2,SWX2,SX,SX1,SXC,SXC1,SXE,SXE1,VMQ3,VMT3,VPXB,VPXE,VS4,VS6,VS4,VTE5,VX,VX1,VXE,VXK,VXU1
			2	-	0001867	0281238 VPX4,VSP
10	28461-Z2E-003	GRIP, STARTER	1	-	0386426	EDS1,EDT1,ES2,LH,LH1,LH2,LHB5,LHP1,LXE9,PX,QA2,QBE1,QEBR,QH,QH1,QHB1,QHB3,QHB5,QHBR,QHP1,QMH,QN,QP,QX,QXBR,QXE,QXEK,QXHQ,QXK,SH,SH1,SHE,SM11,SWE2,SWX2,SX,SX1,SXC,SXC1,SXE,SXE1,VMQ3,VMT3,VPXB,VPXE,VPXJ,VS4,VS6,VS4,VTE5,VX,VX1,VXE,VXK,VXU1
			1	-	0001867	0386426 VPX4,VSP
11	28462-Z2E-003	ROPE, RECOIL STARTER	1	-	0281238	EDS1,EDT1,ES2,LH,LH1,LH2,LHB5,LHP1,LXE9,PX,QA2,QBE1,QH,QH1,QHB1,QHB3,QHB5,QHP1,QMH,QN,QP,QX,QXE,QXEK,QXHQ,QXK,SH,SH1,SHE,SM11,SWE2,SWX2,SX,SX1,SXC,SXC1,SXE,SXE1,VMQ3,VMT3,VPXB,VPXE,VS4,VS6,VS4,VTE5,VX,VX1,VXE,VXK,VXU1
	28462-Z7E-701	1	-	0386426	QEBR,QHBR,QXBR,VPXJ
	28462-Z2E-003	1	-	0001867	0281238 VPX4,VSP
	28462-Z7E-701	1	-	0281239	0386426 EDS1,EDT1,ES2,LH,LH1,LH2,LHB5,LHP1,LXE9,PX,QA2,QBE1,QH,QH1,QHB1,QHB3,QHB5,QHP1,QMH,QN,QP,QX,QXE,QXEK,QXHQ,QXK,SH,SH1,SHE,SM11,SWE2,SWX2,SX,SX1,SXC,SXC1,SXE,SXE1,VMQ3,VMT3,VPXB,VPXE,VS4,VS6,VS4,VTE5,VX,VX1,VXE,VXK,VXU1
12	90003-ZH8-801	SCREW, SETTING	1	-	0281238	EDS1,EDT1,ES2,LH,LH1,LH2,LHB5,LHP1,LXE9,PX,QA2,QBE1,QH,QH1,QHB1,QHB3,QHB5,QHP1,QMH,QN,QP,QX,QXE,QXEK,QXHQ,QXK,SH,SH1,SHE,SM11,SWE2,SWX2,SX,SX1,SXC,SXC1,SXE,SXE1,VMQ3,VMT3,VPXB,VPXE,VS4,VS6,VS4,VTE5,VX,VX1,VXE,VXK,VXU1
			1	-	0001867	0281238 VPX4,VSP
13	90008-Z1T-000	BOLT, FLANGE, 6X10	3	-	0386426	EDS1,EDT1,ES2,LH,LH1,LH2,LHB5,LHP1,LXE9,PX,QA2,QBE1,QEBR,QH,QH1,QHB1,QHB3,QHB5,QHBR,QHP1,QMH,QN,QP,QX,QXBR,QXE,QXEK,QXHQ,QXK,SH,SH1,SHE,SM11,SWE2,SWX2,SX,SX1,SXC,SXC1,SXE,SXE1,VMQ3,VMT3,VPXB,VPXE,VPXJ,VS4,VS6,VS4,VTE5,VX,VX1,VXE,VXK,VXU1
			3	-	0001867	0386426 VPX4,VSP



E-11

RECOIL STARTER(1)

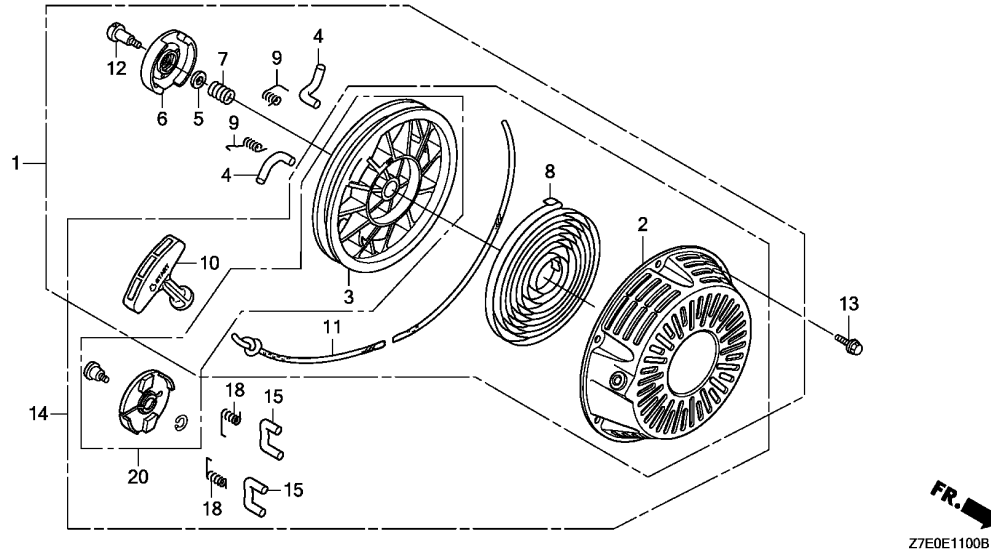

Z7E0E1100B

Ref. No.	Part No.	Description	Reqd. QTY		Serial No.	Parts catalogue code
			GX 390 H1	GX 390 H2		
14	28400-Z7E-701ZA	STARTER ASSY., RECOIL *R280*.....POWER RED	1	-	-----	0386426 QEBR,QHBR,QXBR,VPXJ
			1	-	0281239	0386426 EDS1,EDT1,ES2,LH,LH1,LH2,LHB5,LHP1,LXE9,PX,QA2,QBE1,QH,QH1,QHB1,QHB3,QHB5,QHP1,QMH,QN,QP,QX,QXE,QXEK,QXHQ,QXK,SH,SH1,SHE,SM11,SWE2,SWX2,SX,SX1,SXC,SXC1,SXE,SXE1,VMQ3,VMT3,VPX4,VPXB,VPXE,VS4,VS6,VS4,VS6,VS4,VSP,VTE5,VX,VX1,VXE,VXK,VXU1
	28400-Z7E-701ZB	*NH1*.....BLACK	1	-	0281239	0386426 EDS1,EDT1,QXHQ,SX,VSP
15	28422-Z7E-701	RATCHET, STARTER	2	-	-----	0386426 QEBR,QHBR,QXBR,VPXJ
			2	-	0281239	0386426 EDS1,EDT1,ES2,LH,LH1,LH2,LHB5,LHP1,LXE9,PX,QA2,QBE1,QH,QH1,QHB1,QHB3,QHB5,QHP1,QMH,QN,QP,QX,QXE,QXEK,QXHQ,QXK,SH,SH1,SHE,SM11,SWE2,SWX2,SX,SX1,SXC,SXC1,SXE,SXE1,VMQ3,VMT3,VPX4,VPXB,VPXE,VS4,VS6,VS4,VS6,VS4,VSP,VTE5,VX,VX1,VXE,VXK,VXU1
18	28443-Z1T-701	SPRING, RETURN	2	-	-----	0386426 QEBR,QHBR,QXBR,VPXJ
			2	-	0281239	0386426 EDS1,EDT1,ES2,LH,LH1,LH2,LHB5,LHP1,LXE9,PX,QA2,QBE1,QH,QH1,QHB1,QHB3,QHB5,QHP1,QMH,QN,QP,QX,QXE,QXEK,QXHQ,QXK,SH,SH1,SHE,SM11,SWE2,SWX2,SX,SX1,SXC,SXC1,SXE,SXE1,VMQ3,VMT3,VPX4,VPXB,VPXE,VS4,VS6,VS4,VS6,VS4,VSP,VTE5,VX,VX1,VXE,VXK,VXU1
20	06280-Z7E-305	STARTER SET, RECOIL	1	-	-----	0386426 QEBR,QHBR,QXBR,VPXJ
			1	-	0281239	0386426 EDS1,EDT1,ES2,LH,LH1,LH2,LHB5,LHP1,LXE9,PX,QA2,QBE1,QH,QH1,QHB1,QHB3,QHB5,QHP1,QMH,QN,QP,QX,QXE,QXEK,QXHQ,QXK,SH,SH1,SHE,SM11,SWE2,SWX2,SX,SX1,SXC,SXC1,SXE,SXE1,VMQ3,VMT3,VPX4,VPXB,VPXE,VS4,VS6,VS4,VS6,VS4,VSP,VTE5,VX,VX1,VXE,VXK,VXU1

E-11-1

RECOIL STARTER(2)

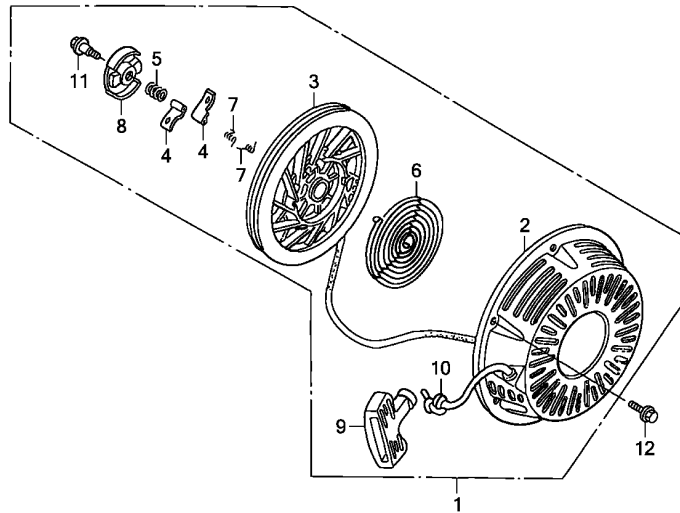

Z7E0E1101

Ref. No.	L.O.N.	(Relative ref. Number) Description	F.R.T.
1	1121B9	STARTER, RECOIL	0.1
3	1121B1	REEL, RECOIL STARTER	0.3
4	1121B0	STARTER RATCHET AND/OR SPRING .NOTE: Same time for two units	0.2
6	1121B7	SPRING, RECOIL STARTER RETURN (5)	0.3
8	1121B2	RETAINER, SPRING	0.2
9	1121A3	GRIP, RECOIL STARTER	0.1
10	1121B3	ROPE, RECOIL STARTER	0.3

Ref. No.	Part No.	Description	Reqd. QTY		Serial No.	Parts catalogue code
			GX 390 H1	GX 390 H2		
1	28400-ZE3-W01ZB	STARTER ASSY., RECOIL	1	-	----- ES3S,ES4S	
	NH1.....	BLACK	1	-	----- 0001866 VPX4,VSP	
	28400-ZE3-W01ZP	*R280*.....POWER RED	1	-	----- 0001866 VPX4,VSP	
2	28410-ZE3-W01ZB	CASE COMP., RECOIL STARTER	1	-	----- ES3S,ES4S	
	NH1.....	BLACK	1	-	----- 0001866 VPX4,VSP	
	28410-ZE3-W01ZP	*R280*.....POWER RED	1	-	----- 0001866 VPX4,VSP	
3	28421-ZE3-W01	PULLEY, RECOIL STARTER	1	-	----- ES3S,ES4S	
			1	-	----- 0001866 VPX4,VSP	
4	28422-ZE2-W01	RATCHET, STARTER	2	-	----- ES3S,ES4S	
			2	-	----- 0001866 VPX4,VSP	
5	28441-ZE2-W01	SPRING, FRICTION	1	-	----- ES3S,ES4S	
			1	-	----- 0001866 VPX4,VSP	
6	28442-ZE2-W01	SPRING, STARTER RETURN	1	-	----- ES3S,ES4S	
			1	-	----- 0001866 VPX4,VSP	
7	28443-ZE2-W01	SPRING, RATCHET	2	-	----- ES3S,ES4S	
			2	-	----- 0001866 VPX4,VSP	
8	28444-ZE2-W01	RETAINER, SPRING	1	-	----- ES3S,ES4S	
			1	-	----- 0001866 VPX4,VSP	
9	28461-ZE2-W02	GRIP, STARTER	1	-	----- ES3S,ES4S	
			1	-	----- 0001866 VPX4,VSP	
10	28462-ZE3-W01	ROPE, RECOIL STARTER	1	-	----- ES3S,ES4S	
			1	-	----- 0001866 VPX4,VSP	
11	90004-ZE2-W01	SCREW, CENTER	1	-	----- ES3S,ES4S	
			1	-	----- 0001866 VPX4,VSP	
12	90008-Z1T-000	BOLT, FLANGE, 6X10	3	-	----- ES3S,ES4S	
	90008-ZE2-003	3	-	----- 0001866 VPX4,VSP	

E-11-2

RECOIL STARTER(3)

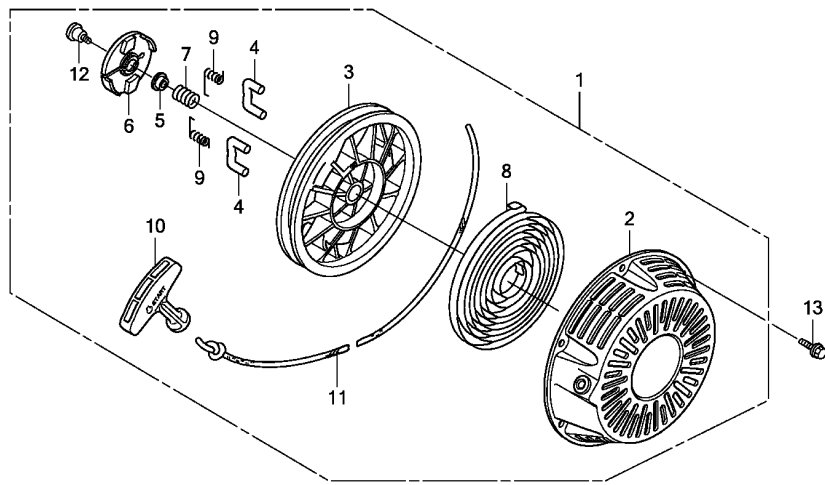

FR. →
Z7E0E1102

Ref. No.	L.O.N.	(Relative ref. Number) Description	F.R.T.
1	1121B9	STARTER, RECOIL	0.1
3	1121B1	REEL, RECOIL STARTER	0.3
4		(9)	
4	1121B0	STARTER RATCHET AND/OR SPRING	0.2
6		(7)	
6	1121A4	GUIDE, RATCHET	0.2
8	1121B7	SPRING, RECOIL STARTER RETURN	0.3
10	1121A3	GRIP, RECOIL STARTER	0.1
11	1121B3	ROPE, RECOIL STARTER	0.3

Ref. No.	Part No.	Description	Reqd. QTY		Serial No.	Parts catalogue code
			GX 390 H1	GX 390 H2		
1	28400-Z7E-702ZB	STARTER ASSY., RECOIL	1	-		EDF6,EDS2,VPKK,VPXK,VPXX
		NH1.....BLACK	1	-		QHE,VPKK,VPXK,VPXX,VX1M,VXEK,VXEM,VXKS
	28400-Z7E-702ZA	*R280*.....POWER RED	1	-	0386427	EDS1,EDT1,ES2,LH,LH1,LH2,LHB5,LHP1,LXE9,PX,QA2,QBE1,QEBR,QH,QH1,QHB1
						QHB3,QHB5,QHBR,QHP1,QMH,QN,QP,QX,QXBR,QXE,QXEK,QXHQ,QXK,SH,SH1,SHE
						SM11,SWE2,SWX2,SX,SX1,SXC,SXC1,SXE,SXE1,VMQ3,VMT3,VPX4,VPXB,VPXE,VPXJ
						VS4,VS6,VS4,VSP,VTE5,VX,VX1,VXE,VXK,VXU1
	28400-Z7E-702ZB	*NH1*.....BLACK	1	-	0386427	EDS1,EDT1,QXHQ,SX,VSP
	28400-Z7E-702ZA	*R280*.....POWER RED	-	1		
	28400-Z7E-702ZB	*NH1*.....BLACK	-	1		
2	28410-Z7E-701ZB	CASE COMP., RECOIL STARTER	1	-		EDF6,EDS2,VPKK,VPXK,VPXX
		NH1.....BLACK	1	-		QHE,VPKK,VPXK,VPXX,VX1M,VXEK,VXEM,VXKS
	28410-Z7E-701ZA	*R280*.....POWER RED	1	-	0386427	EDS1,EDT1,ES2,LH,LH1,LH2,LHB5,LHP1,LXE9,PX,QA2,QBE1,QEBR,QH,QH1,QHB1
						QHB3,QHB5,QHBR,QHP1,QMH,QN,QP,QX,QXBR,QXE,QXEK,QXHQ,QXK,SH,SH1,SHE
						SM11,SWE2,SWX2,SX,SX1,SXC,SXC1,SXE,SXE1,VMQ3,VMT3,VPX4,VPXB,VPXE,VPXJ
						VS4,VS6,VS4,VSP,VTE5,VX,VX1,VXE,VXK,VXU1
	28410-Z7E-701ZB	*NH1*.....BLACK	1	-	0386427	EDS1,EDT1,QXHQ,SX,VSP
	28410-Z7E-701ZA	*R280*.....POWER RED	-	1		
	28410-Z7E-701ZB	*NH1*.....BLACK	-	1		
3	28420-Z7E-702	REEL, RECOIL STARTER(BLACK)	1	-		EDF6,EDS2,QHE,VPKK,VPXK,VPXX,VX1M,VXEK,VXEM,VXKS
			1	-	0386427	EDS1,EDT1,ES2,LH,LH1,LH2,LHB5,LHP1,LXE9,PX,QA2,QBE1,QEBR,QH,QH1,QHB1
						QHB3,QHB5,QHBR,QHP1,QMH,QN,QP,QX,QXBR,QXE,QXEK,QXHQ,QXK,SH,SH1,SHE
						SM11,SWE2,SWX2,SX,SX1,SXC,SXC1,SXE,SXE1,VMQ3,VMT3,VPX4,VPXB,VPXE,VPXJ
						VS4,VS6,VS4,VSP,VTE5,VX,VX1,VXE,VXK,VXU1
			-	1		

E-11-2

RECOIL STARTER(3)

Ref. No.	Part No.	Description	Reqd. QTY		Serial No.	Parts catalogue code
			GX 390 H1	GX 390 H2		
4	28422-Z7E-701	RATCHET, STARTER	2	-	-----	EDF6,EDS2,QHE,VPKK,VPXK,VPXX,VX1M,VXEK,VXEM,VXKS
			2	-	0386427	----- EDS1,EDT1,ES2,LH,LH1,LH2,LHB5,LHP1,LXE9,PX,QA2,QBE1,QEBR,QH,QH1,QHB1 QHB3,QHB5,QHBR,QHP1,QMH,QN,QP,QX,QXBR,QXE,QXEK,QXHQ,QXK,SH,SH1,SHE SM11,SWE2,SWX2,SX,SX1,SXC,SXC1,SXE,SXE1,VMQ3,VMT3,VPX4,VPXB,VPXE,VPXJ VS4,VS6,VS4,VSP,VTE5,VX,VX1,VXE,VXK,VXU1
5	28431-Z2E-003	PLATE, FRICTION	-	2	-----	EDF6,EDS2,QHE,VPKK,VPXK,VPXX,VX1M,VXEK,VXEM,VXKS
			1	-	0386427	----- EDS1,EDT1,ES2,LH,LH1,LH2,LHB5,LHP1,LXE9,PX,QA2,QBE1,QEBR,QH,QH1,QHB1 QHB3,QHB5,QHBR,QHP1,QMH,QN,QP,QX,QXBR,QXE,QXEK,QXHQ,QXK,SH,SH1,SHE SM11,SWE2,SWX2,SX,SX1,SXC,SXC1,SXE,SXE1,VMQ3,VMT3,VPX4,VPXB,VPXE,VPXJ VS4,VS6,VS4,VSP,VTE5,VX,VX1,VXE,VXK,VXU1
6	28433-Z7E-702	GUIDE, RATCHET	1	-	-----	EDF6,EDS2,QHE,VPKK,VPXK,VPXX,VX1M,VXEK,VXEM,VXKS
			1	-	0386427	----- EDS1,EDT1,ES2,LH,LH1,LH2,LHB5,LHP1,LXE9,PX,QA2,QBE1,QEBR,QH,QH1,QHB1 QHB3,QHB5,QHBR,QHP1,QMH,QN,QP,QX,QXBR,QXE,QXEK,QXHQ,QXK,SH,SH1,SHE SM11,SWE2,SWX2,SX,SX1,SXC,SXC1,SXE,SXE1,VMQ3,VMT3,VPX4,VPXB,VPXE,VPXJ VS4,VS6,VS4,VSP,VTE5,VX,VX1,VXE,VXK,VXU1
7	28441-Z2E-003	SPRING, FRICTION	-	1	-----	EDF6,EDS2,QHE,VPKK,VPXK,VPXX,VX1M,VXEK,VXEM,VXKS
			1	-	0386427	----- EDS1,EDT1,ES2,LH,LH1,LH2,LHB5,LHP1,LXE9,PX,QA2,QBE1,QEBR,QH,QH1,QHB1 QHB3,QHB5,QHBR,QHP1,QMH,QN,QP,QX,QXBR,QXE,QXEK,QXHQ,QXK,SH,SH1,SHE SM11,SWE2,SWX2,SX,SX1,SXC,SXC1,SXE,SXE1,VMQ3,VMT3,VPX4,VPXB,VPXE,VPXJ VS4,VS6,VS4,VSP,VTE5,VX,VX1,VXE,VXK,VXU1
8	28442-Z7E-003	SPRING, RECOIL STARTER	-	1	-----	EDF6,EDS2,QHE,VPKK,VPXK,VPXX,VX1M,VXEK,VXEM,VXKS
			1	-	0386427	----- EDS1,EDT1,ES2,LH,LH1,LH2,LHB5,LHP1,LXE9,PX,QA2,QBE1,QEBR,QH,QH1,QHB1 QHB3,QHB5,QHBR,QHP1,QMH,QN,QP,QX,QXBR,QXE,QXEK,QXHQ,QXK,SH,SH1,SHE SM11,SWE2,SWX2,SX,SX1,SXC,SXC1,SXE,SXE1,VMQ3,VMT3,VPX4,VPXB,VPXE,VPXJ VS4,VS6,VS4,VSP,VTE5,VX,VX1,VXE,VXK,VXU1
9	28443-Z1T-701	SPRING, RETURN	-	1	-----	EDF6,EDS2,QHE,VPKK,VPXK,VPXX,VX1M,VXEK,VXEM,VXKS
			2	-	0386427	----- EDS1,EDT1,ES2,LH,LH1,LH2,LHB5,LHP1,LXE9,PX,QA2,QBE1,QEBR,QH,QH1,QHB1 QHB3,QHB5,QHBR,QHP1,QMH,QN,QP,QX,QXBR,QXE,QXEK,QXHQ,QXK,SH,SH1,SHE SM11,SWE2,SWX2,SX,SX1,SXC,SXC1,SXE,SXE1,VMQ3,VMT3,VPX4,VPXB,VPXE,VPXJ VS4,VS6,VS4,VSP,VTE5,VX,VX1,VXE,VXK,VXU1
10	28461-Z2E-003	GRIP, STARTER	-	2	-----	EDF6,EDS2,QHE,VPKK,VPXK,VPXX,VX1M,VXEK,VXEM,VXKS
			1	-	0386427	----- EDS1,EDT1,ES2,LH,LH1,LH2,LHB5,LHP1,LXE9,PX,QA2,QBE1,QEBR,QH,QH1,QHB1 QHB3,QHB5,QHBR,QHP1,QMH,QN,QP,QX,QXBR,QXE,QXEK,QXHQ,QXK,SH,SH1,SHE SM11,SWE2,SWX2,SX,SX1,SXC,SXC1,SXE,SXE1,VMQ3,VMT3,VPX4,VPXB,VPXE,VPXJ VS4,VS6,VS4,VSP,VTE5,VX,VX1,VXE,VXK,VXU1
11	28462-Z7E-701	ROPE, RECOIL STARTER	-	1	-----	EDF6,EDS2,QHE,VPKK,VPXK,VPXX,VX1M,VXEK,VXEM,VXKS
			1	-	0386427	----- EDS1,EDT1,ES2,LH,LH1,LH2,LHB5,LHP1,LXE9,PX,QA2,QBE1,QEBR,QH,QH1,QHB1 QHB3,QHB5,QHBR,QHP1,QMH,QN,QP,QX,QXBR,QXE,QXEK,QXHQ,QXK,SH,SH1,SHE SM11,SWE2,SWX2,SX,SX1,SXC,SXC1,SXE,SXE1,VMQ3,VMT3,VPX4,VPXB,VPXE,VPXJ VS4,VS6,VS4,VSP,VTE5,VX,VX1,VXE,VXK,VXU1
12	90003-ZH8-801	SCREW, SETTING	-	1	-----	EDF6,EDS2,QHE,VPKK,VPXK,VPXX,VX1M,VXEK,VXEM,VXKS
			1	-	0386427	----- EDS1,EDT1,ES2,LH,LH1,LH2,LHB5,LHP1,LXE9,PX,QA2,QBE1,QEBR,QH,QH1,QHB1 QHB3,QHB5,QHBR,QHP1,QMH,QN,QP,QX,QXBR,QXE,QXEK,QXHQ,QXK,SH,SH1,SHE SM11,SWE2,SWX2,SX,SX1,SXC,SXC1,SXE,SXE1,VMQ3,VMT3,VPX4,VPXB,VPXE,VPXJ VS4,VS6,VS4,VSP,VTE5,VX,VX1,VXE,VXK,VXU1
			-	1	-----	EDF6,EDS2,QHE,VPKK,VPXK,VPXX,VX1M,VXEK,VXEM,VXKS

E-11-2

RECOIL STARTER(3)

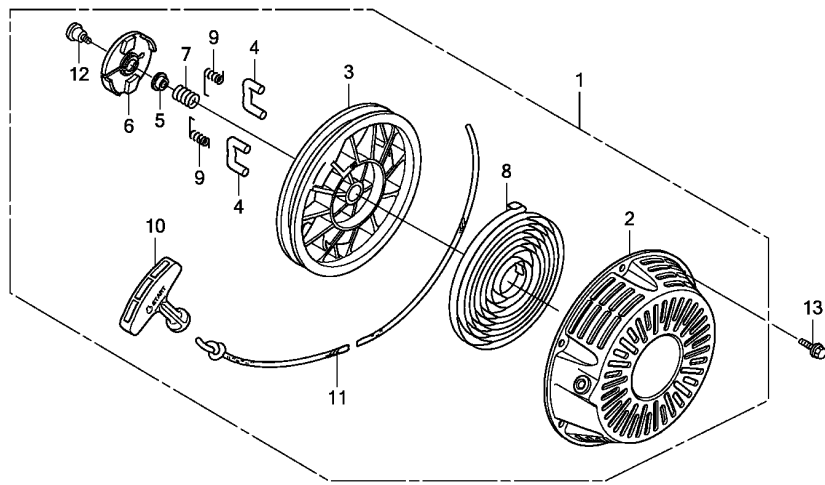

FR. Z7E0E1102

Ref. No.	Part No.	Description	Reqd. QTY		Serial No.	Parts catalogue code
			GX 390 H1	GX 390 H2		
13	90008-Z1T-000	BOLT, FLANGE, 6X10	3	-	-----	EDF6,EDS2,QHE,VPKK,VPXK,VPXX,VX1M,VXEK,VXEM,VXKS
			3	-	0386427 -----	EDS1,EDT1,ES2,LH,LH1,LH2,LHB5,LHP1,LXE9,PX,QA2,QBE1,QEBR,QH,QH1,QHB1,QHB3,QHB5,QHBR,QHP1,QMH,QN,QP,QX,QXBR,QXE,QXEK,QXHQ,QXK,SH,SH1,SHE,SM11,SWE2,SWX2,SX,SX1,SXC,SXC1,SXE,SXE1,VMQ3,VMT3,VPX4,VPXB,VPXE,VPXJ,VS4,VS6,VS84,VSP,VTE5,VX,VX1,VXE,VXK,VXU1
	95701-06010-00	-	3		

2

E-12

FAN COVER

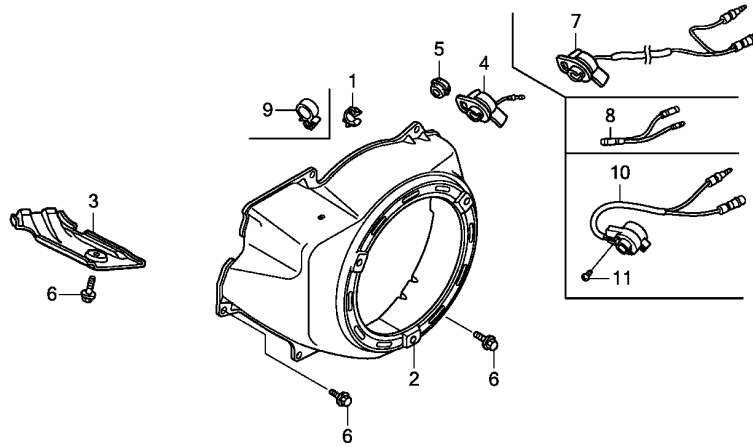

Ref. No.	L.O.N.	(Relative ref. Number) Description	F.R.T.
2	1141G8	COVER, ENGINE COOLING FAN ---- (7,10)	0.2
4	6151D9	SWITCH, ENGINE STOP	0.1
8	6111E5	SUB HARNESS, OIL LEVEL SWITCH	0.1

Ref. No.	Part No.	Description	Reqd. QTY		Serial No.	Parts catalogue code
			GX 390 H1	GX 390 H2		
1	16731-Z7E-000	CLIP, TUBE	1	1	-----	LH, LH1, LH2, LHB5, LHP1, LXE9, PX, QA2, QBE1, QEBR, QH, QH1, QHB1, QHB3, QHB5, QHBR, QHE, QHP1, QMH, QN, QP, QX, QXBR, QXE, QXEK, QXHQ, QXK, SH, SH1, SHE, SM11, SWE2, SWX2, SX, SX1, SXC, SXC1, SXE, SXE1, VPKK, VPXB, VPXE, VPXJ, VPXK, VPXX, VTE5, VX, VX1, VX1M, VXE, VXEK, VDEM, VVK, VVKS, VXU1
	16731-ZE2-003	1	-	0012811	VPX4, VSP
	16731-Z7E-000	1	-	0012812	VPX4, VSP
2	19610-Z7E-800ZA	COVER COMP., FAN *NH1*.....BLACK	1	-	-----	EDF6, EDS1, EDS2, EDT1, ES3S, ES4S
	19610-Z7E-800ZB	*R280*.....POWER RED	1	-	-----	EDS1, EDT1, ES2, VMQ3, VMT3, VS4, VS6, VSB4
	19610-Z7E-000ZB	*R280*.....POWER RED	1	-	-----	LH, LH1, LH2, LHB5, LHP1, LXE9, PX, QA2, QBE1, QEBR, QH, QH1, QHB1, QHB3, QHB5, QHBR, QHE, QHP1, QMH, QN, QP, QX, QXBR, QXE, QXEK, QXHQ, QXK, SH, SH1, SHE, SM11, SWE2, SWX2, SX, SX1, SXC, SXC1, SXE, SXE1, VPKK, VPXB, VPXE, VPXJ, VPXK, VPXX, VTE5, VX, VX1, VX1M, VXE, VXEK, VDEM, VVK, VVKS, VXU1
	19610-Z7E-000ZA	*NH1*.....BLACK	1	-	-----	QXHQ, SX, VPKK, VPXK, VPXX
	19610-ZE3-010ZL	*R280*.....POWER RED	1	-	-----	VSP
	19610-ZE3-W02ZF	*R280*.....POWER RED	1	-	0003244	VPX4
	19610-Z7E-000ZB	*R280*.....POWER RED	1	-	0003245	VPX4
	19610-Z5T-800ZA	*R280*.....POWER RED	-	1	-----	EDS1, EDS2, EDT1, ES2
	19610-Z5T-800ZC	*NH1*.....BLACK	-	1	-----	EDS1, EDS2, EDT1, ES2
	19610-Z5T-000ZA	*R280*.....POWER RED	-	1	-----	LH, LH1, PX, QH, QH1, QHE, QMH, QN, QX, QXE, QXHQ, SH, SH1, SHE, SM11, SWX2, SX, SX1, SXC, SXC1, VPKK, VPXB, VPXE, VPXK, VPXX, VTE5, VX, VX1, VX1M, VXE, VXEK, VDEM, VVKS
	19610-Z5T-000ZB	*NH1*.....BLACK	-	1	-----	LH, LH1, PX, QH, QH1, QHE, QMH, QN, QX, QXE, QXHQ, SH, SH1, SHE, SM11, SWX2, SX, SX1, SXC, SXC1, VPKK, VPXB, VPXE, VPXK, VPXX, VTE5, VX, VX1, VX1M, VXE, VXEK, VDEM, VVKS
3	19631-ZE3-W00	SHROUD	1	-	-----	
	19631-Z5T-000	-	1	-----	
4	35120-Z0D-V81	SWITCH ASSY., ENGINE STOP ...	1	-	-----	LH, LH1, LH2, LHB5, LHP1, QH, QH1, QHB3, QHB5, QHBR, QHP1, QMH, QN, QP, SH, SH1, SM11
	35120-Z0T-801	1	-	-----	LH1, LH2, LHB5, LHP1, QH1, QHB3, QHB5, QHBR, QHP1, QMH, QN, QP, SH1

E-12

FAN COVER

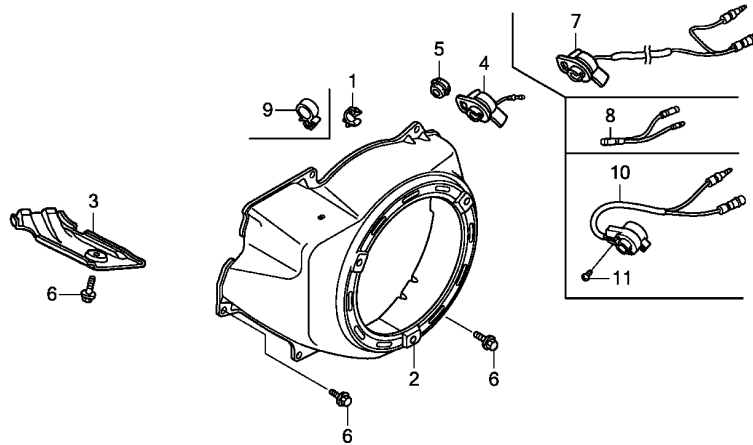

FR. →
Z7E0E1200C

Ref. No.	Part No.	Description	Reqd. QTY		Serial No.	Parts catalogue code
			GX 390 H1	GX 390 H2		
5	81329-567-020	GROMMET, DRAIN HOLE	1	1	-----	EDF6,EDS1,EDS2,EDT1,ES2,ES3S,ES4S,LXE9,QBE1,QEBR,QHB1,QHE,QXE,QXEK SHE,SWE2,SXE,SXE1,VMQ3,VMT3,VPKK,VPX4,VPXB,VPXE,VPXJ,VPXK,VPXX,VS4 VS6,VS4, VTE5, VXE, VXEK, VXEM, VXX, VXXS, VXU1
6	90013-883-000	BOLT, FLANGE, 6X12(CT200) ...	6	6	-----	PX,QA2,QX,QXBR,QXHQ,QXK,SWX2,SX,SX1,SXC,SXC1,VSP,VX,VX1,VX1M
7	36100-ZF6-P82 35120-Z0T-851	SWITCH ASSY., ENGINE STOP ...	1	-	-----	PX,QX,QXBR,QXK,SWX2,SX1,SXC1,VX1,VX1M
8	32197-ZH8-003 32197-Z1T-000	SUB HARNESS	1	-	-----	EDF6,EDS1,EDS2,EDT1
9	90654-SA4-003	CLIP, WIRE HARNESS, 6MM(WHITE)	2	2	-----	EDF6,EDS1,EDS2,EDT1,ES2,ES3S,ES4S,VMQ3,VMT3,VS4,VS6,VS4
10	35120-Z7E-931	SWITCH ASSY., ENGINE STOP ...	-	1	-----	LH,LH1,PX,QH,QH1,QMH,QN,QX,QXHQ,SH,SH1,SM11,SWX2,SX,SX1,SXC,SXC1,VX VX1,VX1M
11	90004-Z5T-000	SCREW, TAPPING, 3X6(P0)	-	2	-----	LH,LH1,PX,QH,QH1,QMH,QN,QX,QXHQ,SH,SH1,SM11,SWX2,SX,SX1,SXC,SXC1,VX VX1,VX1M

E-14

CARBURETOR(1)

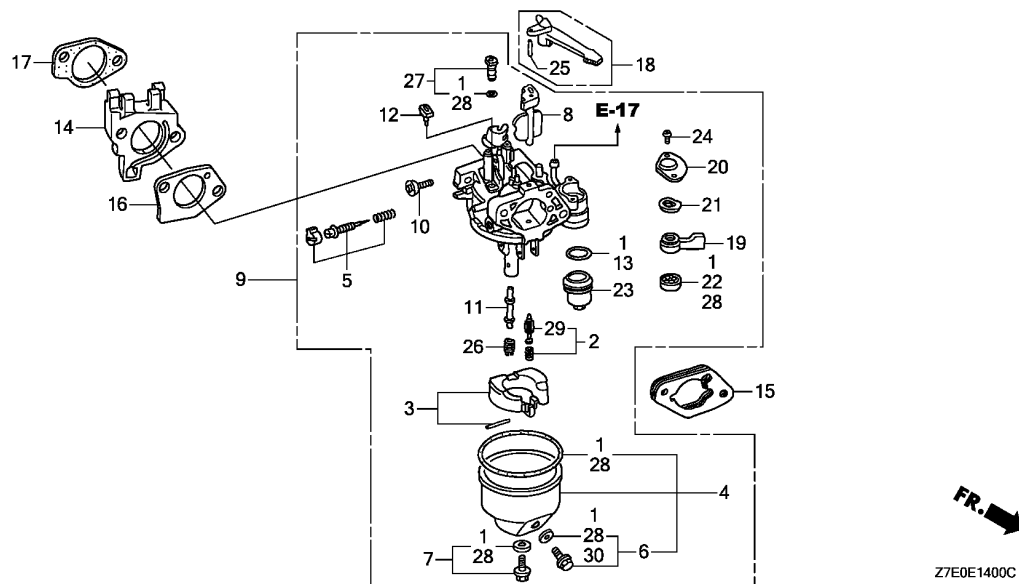

Ref. No.	L.O.N.	(Relative ref. Number) Description	F.R.T.
1		(28)	
1	3111B1	GASKET SET, CARBURETOR	0.3
2		(3,29)	
2	3111E1	FLOAT VALVE SET AND/OR FLOAT SET	0.3
4	3111A3	FLOAT CHAMBER SET AND/OR GASKET	0.2
5	3111D7	SCREW SET, PILOT	0.2
8	8101C5	CHOKE SET, CARBURETOR	0.2
9	3111F3	CARBURETOR	0.2
13		(23)	
13	3101L6	PACKING, FUEL STRAINER CUP ...	0.2
14		(17)	
14	3111C0	CARBURETOR INSULATOR AND/OR PACKING	0.2
15	3111D9	SPACER, CARBURETOR	0.2
16	3111C8	PACKING, CARBURETOR	0.2
18	8101F9	LEVER, CARBURETOR CHOKE	0.2
22		(19,20,21)	
26	3101C5	PACKING, FUEL COCK	0.2
26		(11)	
26	3111C3	JET, MAIN	0.3

Ref. No.	Part No.	Description	Reqd. QTY		Serial No.	Parts catalogue code
			GX 390 H1	GX 390 H2		
1	16010-ZE2-812	GASKET SET	1	-	-----	LH,LH1,LH2,LHB5,LHP1,LXE9,PX,QA2,QEBR,QH,QH1,QHB3,QHB5,QHBR,QHE,QHP1,QMH,QN,QX,QXBR,QXE,QXEK,QXHQ,QXK,SH,SH1,SHE,SM11,SX,SX1,SXC,SXC1,SXE,SXE1,VSP,VX,VX1,VX1M,VXE,VXEM,VXK,VXU1
	16010-Z7E-971	-	1	-----	LH,LH1,PX,QH,QH1,QHE,QMH,QN,QX,QXE,QXHQ,SH,SH1,SHE,SM11,SWX2,SX,SX1,SXC,SXC1,VTE5,VX,VX1,VX1M,VXE,VXEM
2	16011-ZA0-931	VALVE SET, FLOAT	1	-	-----	QBE1,QHB1,QP,SWE2,SWX2,VSP,VTE5
		(CARBURETOR NO.)	1	-	-----	BE85T A LH,LH1,LH2,LHB5,LHP1,LXE9,PX,QA2,QH,QH1,QHB3,QHB5,QHP1,QMH,QX,QXE,QXEK,QXHQ,QXK,SH,SH1,SHE,SM11,SX,SX1,SXC,SXC1,SXE,SXE1
		//	1	-	-----	BE85U A QN,VX,VX1,VXE,VXK,VXU1
		//	1	-	-----	BE6AC A ----- QEBR,QHBR,QXBR
3	16013-Z1C-003	FLOAT SET	1	-	-----	QBE1,QHB1,QP,SWE2,SWX2,VSP,VTE5
	16013-Z7E-701	1	-	-----	QHE,VX1M,VXEM
	16013-Z1C-003	(CARBURETOR NO.)	1	-	-----	BE85T A LH,LH1,LH2,LHB5,LHP1,LXE9,PX,QA2,QH,QH1,QHB3,QHB5,QHP1,QMH,QX,QXE,QXEK,QXHQ,QXK,SH,SH1,SHE,SM11,SX,SX1,SXC,SXC1,SXE,SXE1
	16013-Z7E-701	(CARBURETOR NO.)	1	-	-----	BE85T B QEBR,QHBR,QXBR
	16013-Z1C-003	(CARBURETOR NO.)	1	-	-----	BE85U A QN,VX,VX1,VXE,VXK,VXU1
	16013-Z7E-701	//	1	-	-----	BE6AC A ----- QEBR,QHBR,QXBR
	16013-Z7E-701	(CARBURETOR NO.)	1	-	-----	BE85T B ----- LH,LH1,LH2,LHB5,LHP1,LXE9,PX,QA2,QH,QH1,QHB3,QHB5,QHP1,QMH,QX,QXE,QXEK,QXHQ,QXK,SH,SH1,SHE,SM11,SX,SX1,SXC,SXC1,SXE,SXE1
		//	1	-	-----	BE88Q A ----- QN,VX,VX1,VXE,VXK,VXU1
		//	-	1	-----	LH,LH1,PX,QH,QH1,QHE,QMH,QN,QX,QXE,QXHQ,SH,SH1,SHE,SM11,SWX2,SX,SX1,SXC,SXC1,VTE5,VX,VX1,VX1M,VXE,VXEM
4	16015-ZE8-005	CHAMBER SET, FLOAT	1	-	-----	LH,LH1,LH2,LHB5,LHP1,LXE9,PX,QA2,QBE1,QEBR,QH,QH1,QHB1,QHB3,QHB5,QHBR,QHE,QHP1,QMH,QN,QP,QX,QXBR,QXE,QXEK,QXHQ,QXK,SH,SH1,SHE,SM11,SWE2,SWX2,SX,SX1,SXC,SXC1,SXE,SXE1,VSP,VTE5,VX,VX1,VX1M,VXE,VXEM,VXK,VXU1



E-14

CARBURETOR(1)

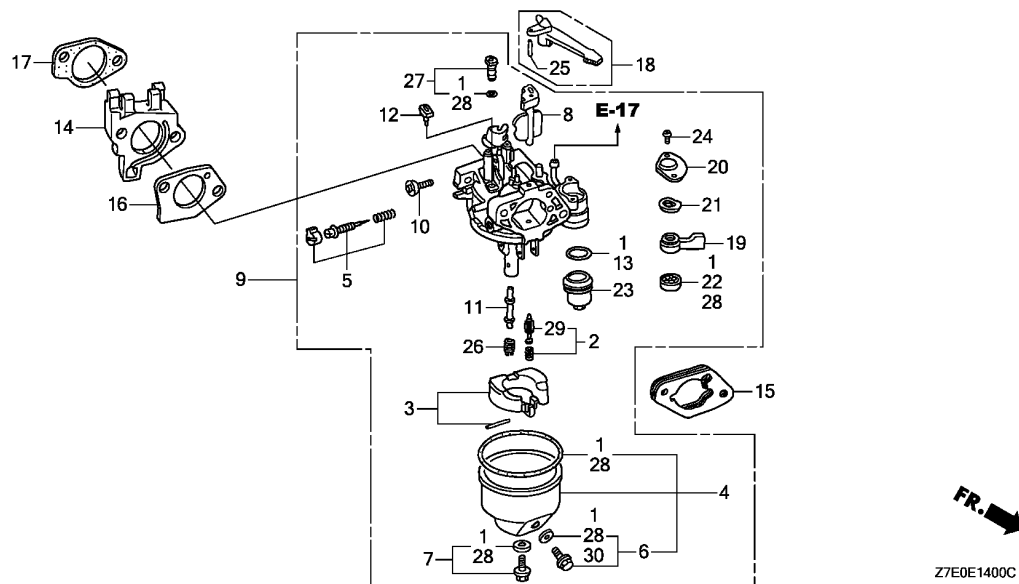

Ref. No.	Part No.	Description	Reqd. QTY		Serial No.	Parts catalogue code
			GX 390 H1	GX 390 H2		
(4)	16015-Z7E-971	CHAMBER SET, FLOAT	-	1	-----	LH,LH1,PX,QH,QH1,QHE,QMH,QN,QX,QXE,QXHQ,SH,SH1,SHE,SM11,SWX2,SX,SX1 SXC,SXC1,VTE5,VX,VX1,VX1M,VXE,VXEM
5	16016-ZH7-W01	SCREW SET, PILOT	1	-	-----	LH,LH1,LH2,LHB5,LHP1,LXE9,PX,QA2,QBE1,QH,QH1,QHB1,QHB3,QHB5,QHE,QHP1 QMH,QN,QP,QX,QXE,QXEK,QXHQ,QXK,SH,SH1,SHE,SM11,SWE2,SWX2,SX,SX1,SXC SXC1,SXE,SXE1,VSP,VTE5,VX,VX1,VX1M,VXE,VXEM,VXK,VXU1
	16016-ZF6-005	(CARBURETOR NO.)	1	-	BE85T B	QEBR,QHBR,QXBR
	16016-Z1E-V21	(CARBURETOR NO.)	1	-	BE6AC A	QEBR,QHBR,QXBR
	16016-Z1E-V21	SCREW SET	-	1	-----	LH,LH1,PX,QH,QH1,QHE,QMH,QN,QX,QXE,QXHQ,SH,SH1,SHE,SM11,SWX2,SX,SX1 SXC,SXC1,VTE5,VX,VX1,VX1M,VXE,VXEM
6	16024-ZE1-811	SCREW SET, DRAIN	1	-	-----	LH,LH1,LH2,LHB5,LHP1,LXE9,PX,QA2,QBE1,QEBR,QH,QH1,QHB1,QHB3,QHB5,QHBR QHE,QHP1,QMH,QN,QP,QX,QXBR,QXE,QXEK,QXHQ,QXK,SH,SH1,SHE,SM11,SWE2 SWX2,SX,SX1,SXC,SXC1,SXE,SXE1,VSP,VTE5,VX,VX1,VX1M,VXE,VXEM,VXK,VXU1
	16024-Z5T-901	-	1	-----	LH,LH1,PX,QH,QH1,QHE,QMH,QN,QX,QXE,QXHQ,SH,SH1,SHE,SM11,SWX2,SX,SX1 SXC,SXC1,VTE5,VX,VX1,VX1M,VXE,VXEM
7	16028-ZE0-005	SCREW SET	1	-	-----	LH,LH1,LH2,LHB5,LHP1,LXE9,PX,QA2,QBE1,QEBR,QH,QH1,QHB1,QHB3,QHB5,QHBR QHE,QHP1,QMH,QN,QP,QX,QXBR,QXE,QXEK,QXHQ,QXK,SH,SH1,SHE,SM11,SWE2 SWX2,SX,SX1,SXC,SXC1,SXE,SXE1,VSP,VTE5,VX,VX1,VX1M,VXE,VXEM,VXK,VXU1
	16028-Z1T-WA1	-	1	-----	LH,LH1,PX,QH,QH1,QHE,QMH,QN,QX,QXE,QXHQ,SH,SH1,SHE,SM11,SWX2,SX,SX1 SXC,SXC1,VTE5,VX,VX1,VX1M,VXE,VXEM
8	16044-ZE3-W20	CHOKE SET	1	-	-----	LH,LH1,LH2,LHB5,LHP1,LXE9,PX,QA2,QBE1,QEBR,QH,QH1,QHB1,QHB3,QHB5,QHBR QHE,QHP1,QMH,QN,QP,QX,QXBR,QXE,QXEK,QXHQ,QXK,SH,SH1,SHE,SM11,SWE2 SWX2,SX,SX1,SXC,SXC1,SXE,SXE1,VSP,VTE5,VX,VX1,VX1M,VXE,VXEM,VXK,VXU1
	16044-Z5T-901	-	1	-----	LH,LH1,PX,QH,QH1,QHE,QMH,QN,QX,QXE,QXHQ,SH,SH1,SHE,SM11,SWX2,SX,SX1 SXC,SXC1,VTE5,VX,VX1,VX1M,VXE,VXEM
9	16100-Z7E-801	CARBURETOR ASSY.(BE85T A/B) ..	1	-	-----	LH,LH1,LH2,LHB5,LHP1,LXE9,PX,QA2,QH,QH1,QHB3,QHB5,QHE,QHP1,QMH,QX,QXE QXEK,QXHQ,QXK,SH,SH1,SHE,SM11,SX,SX1,SXC,SXC1,SXE,SXE1
	16100-Z7E-W31	CARBURETOR ASSY.(BE88P A) ...	1	-	-----	QBE1,QHB1,QP,SWE2,SWX2,VTE5

E-14

CARBURETOR(1)

Ref. No.	Part No.	Description	Reqd. QTY		Serial No.	Parts catalogue code
			GX 390 H1	GX 390 H2		
(9)	16100-Z7E-701	CARBURETOR ASSY.(BE88Q A) ...	1	-	-----	VX1M,VXEM
	16100-Z1C-V51	CARBURETOR ASSY.(BE85L A) ...	1	-	0002573	VSP
	16100-Z7E-811	CARBURETOR ASSY.(BE85U A) ...	1	-	0298099	QN,VX,VX1,VXE,VXK,VXU1
	16100-Z7E-801	CARBURETOR ASSY.(BE85T A/B) ...	1	-	0501806	QEBR,QHBR,QXBR
	16100-Z7E-811	CARBURETOR ASSY.(BE85U A) ...	1	-	0002574	VSP
	16100-Z7E-701	CARBURETOR ASSY.(BE88Q A) ...	1	-	0298100	QN,VX,VX1,VXE,VXK,VXU1
	16100-Z7E-821	CARBURETOR ASSY.(BEA6C A) ...	1	-	0501807	QEBR,QHBR,QXBR
	16100-Z7E-931	CARBURETOR ASSY.(BEA6J A) ...	-	1	-----	LH,LH1,PX,QH,QH1,QHE,QMH,QN,QX,QXE,QXHQ,SH,SH1,SHE,SM11,SWX2,SX,SX1 SXC,SXC1,VTE5,VX,VX1,VX1M,VXE,VXEM
10	16124-ZE0-005	SCREW, THROTTLE STOP	1	1	-----	LH,LH1,LH2,LHB5,LHP1,LXE9,PX,QA2,QBE1,QEBR,QH,QH1,QHB1,QHB3,QHB5,QHBR QHE,QHP1,QMH,QN,QP,QX,QXBR,QXE,QXEK,QXHQ,QXK,SH,SH1,SHE,SM11,SWE2 SWX2,SX,SX1,SXC,SXC1,SXE,SXE1,VSP,VTE5,VX,VX1,VX1M,VXE,VXEM,VXK,VXU1
11	16166-ZF6-V00	NOZZLE, MAIN	1	-	-----	LH,LH1,LH2,LHB5,LHP1,LXE9,PX,QA2,QEBR,QH,QH1,QHB3,QHB5,QHBR,QHE,QHP1 QMH,QN,QX,QXBR,QXE,QXEK,QXHQ,QXK,SH,SH1,SHE,SM11,SX,SX1,SXC,SXC1,SXE SXE1,VSP,VX,VX1,VX1M,VXE,VXEM,VXK,VXU1
	16166-ZF6-W20	1	-	-----	QBE1,QHB1,QP,SWE2,SWX2,VTE5
	16166-Z5T-901	-	1	-----	LH,LH1,PX,QH,QH1,QHE,QMH,QN,QX,QXE,QXHQ,SH,SH1,SHE,SM11,SWX2,SX,SX1 SXC,SXC1,VTE5,VX,VX1,VX1M,VXE,VXEM
12	16172-ZE3-W10	COLLAR, SETTING	1	1	-----	LH,LH1,LH2,LHB5,LHP1,LXE9,PX,QA2,QBE1,QEBR,QH,QH1,QHB1,QHB3,QHB5,QHBR QHE,QHP1,QMH,QN,QP,QX,QXBR,QXE,QXEK,QXHQ,QXK,SH,SH1,SHE,SM11,SWE2 SWX2,SX,SX1,SXC,SXC1,SXE,SXE1,VSP,VTE5,VX,VX1,VX1M,VXE,VXEM,VXK,VXU1
13	16173-001-004	O-RING	1	1	-----	LH,LH1,LH2,LHB5,LHP1,LXE9,PX,QA2,QBE1,QEBR,QH,QH1,QHB1,QHB3,QHB5,QHBR QHE,QHP1,QMH,QN,QP,QX,QXBR,QXE,QXEK,QXHQ,QXK,SH,SH1,SHE,SM11,SWE2 SWX2,SX,SX1,SXC,SXC1,SXE,SXE1,VSP,VTE5,VX,VX1,VX1M,VXE,VXEM,VXK,VXU1
14	16211-Z7E-000	INSULATOR, CARBURETOR	1	-	-----	LH,LH1,LH2,LHB5,LHP1,LXE9,PX,QA2,QBE1,QEBR,QH,QH1,QHB1,QHB3,QHB5,QHBR QHE,QHP1,QMH,QN,QP,QX,QXBR,QXE,QXEK,QXHQ,QXK,SH,SH1,SHE,SM11,SWE2 SWX2,SX,SX1,SXC,SXC1,SXE,SXE1,VTE5,VX,VX1,VX1M,VXE,VXEM,VXK,VXU1
	16211-ZF6-000	1	-	-----	VSP
	16211-Z5T-000	-	1	-----	LH,LH1,PX,QH,QH1,QHE,QMH,QN,QX,QXE,QXHQ,SH,SH1,SHE,SM11,SWX2,SX,SX1 SXC,SXC1,VTE5,VX,VX1,VX1M,VXE,VXEM
15	16220-ZA0-702	SPACER COMP., CARBURETOR	1	1	-----	LH,LH1,LH2,LHB5,LHP1,LXE9,PX,QA2,QBE1,QEBR,QH,QH1,QHB1,QHB3,QHB5,QHBR QHE,QHP1,QMH,QN,QP,QX,QXBR,QXE,QXEK,QXHQ,QXK,SH,SH1,SHE,SM11,SWE2 SWX2,SX,SX1,SXC,SXC1,SXE,SXE1,VSP,VTE5,VX,VX1,VX1M,VXE,VXEM,VXK,VXU1
16	16221-Z7E-701	PACKING, CARBURETOR (NINGBO SIL GASKET)	1	1	-----	LH,LH1,LH2,LHB5,LHP1,LXE9,PX,QA2,QBE1,QEBR,QH,QH1,QHB1,QHB3,QHB5,QHBR QHE,QHP1,QMH,QN,QP,QX,QXBR,QXE,QXEK,QXHQ,QXK,SH,SH1,SHE,SM11,SWE2 SWX2,SX,SX1,SXC,SXC1,SXE,SXE1,VSP,VTE5,VX,VX1,VX1M,VXE,VXEM,VXK,VXU1
	16221-ZF6-800	PACKING, CARBURETOR	1	-	-----	LH,LH1,LH2,LHB5,LHP1,LXE9,PX,QA2,QBE1,QEBR,QH,QH1,QHB1,QHB3,QHB5,QHBR QHE,QHP1,QMH,QN,QP,QX,QXBR,QXE,QXEK,QXHQ,QXK,SH,SH1,SHE,SM11,SWE2 SWX2,SX,SX1,SXC,SXC1,SXE,SXE1,VSP,VTE5,VX,VX1,VX1M,VXE,VXEM,VXK,VXU1
	16221-Z5T-000	-	1	-----	LH,LH1,PX,QH,QH1,QHE,QMH,QN,QX,QXE,QXHQ,SH,SH1,SHE,SM11,SWX2,SX,SX1 SXC,SXC1,VTE5,VX,VX1,VX1M,VXE,VXEM
17	16212-Z7E-701	PACKING, INSULATOR (NINGBO SIL GASKET)	1	-	-----	LH,LH1,LH2,LHB5,LHP1,LXE9,PX,QA2,QBE1,QEBR,QH,QH1,QHB1,QHB3,QHB5,QHBR QHE,QHP1,QMH,QN,QP,QX,QXBR,QXE,QXEK,QXHQ,QXK,SH,SH1,SHE,SM11,SWE2 SWX2,SX,SX1,SXC,SXC1,SXE,SXE1,VSP,VTE5,VX,VX1,VX1M,VXE,VXEM,VXK,VXU1
	16223-ZE3-W00	PACKING, INSULATOR	1	-	-----	LH,LH1,LH2,LHB5,LHP1,LXE9,PX,QA2,QBE1,QEBR,QH,QH1,QHB1,QHB3,QHB5,QHBR QHE,QHP1,QMH,QN,QP,QX,QXBR,QXE,QXEK,QXHQ,QXK,SH,SH1,SHE,SM11,SWE2 SWX2,SX,SX1,SXC,SXC1,SXE,SXE1,VSP,VTE5,VX,VX1,VX1M,VXE,VXEM,VXK,VXU1
	16212-Z5T-000	PACKING, CARBURETOR INSULATOR	-	1	-----	LH,LH1,PX,QH,QH1,QHE,QMH,QN,QX,QXE,QXHQ,SH,SH1,SHE,SM11,SWX2,SX,SX1 SXC,SXC1,VTE5,VX,VX1,VX1M,VXE,VXEM
18	16610-Z1T-000	LEVER COMP., CHOKE(STD.)	1	1	-----	LH,LH1,LH2,LHB5,LHP1,LXE9,PX,QA2,QBE1,QEBR,QH,QH1,QHB1,QHB3,QHB5,QHBR QHE,QHP1,QMH,QN,QP,QX,QXBR,QXE,QXEK,QXHQ,QXK,SH,SH1,SHE,SM11,SWE2 SWX2,SX,SX1,SXC,SXC1,SXE,SXE1,VSP,VTE5,VX,VX1,VX1M,VXE,VXEM,VXK,VXU1

E-14

CARBURETOR(1)

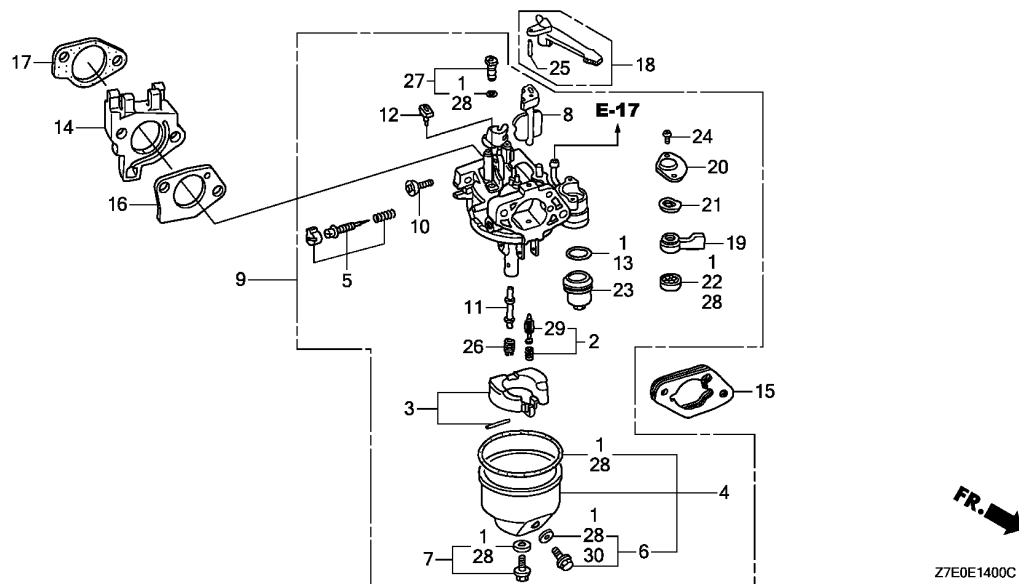

Ref. No.	Part No.	Description	Reqd. QTY		Serial No.	Parts catalogue code
			GX 390 H1	GX 390 H2		
19	16953-ZE1-812	LEVER, COCK	1	-	-----	LH, LH1, LH2, LHB5, LHP1, LXE9, PX, QA2, QBE1, QEBR, QH, QH1, QHB1, QHB3, QHB5, QHBR, QHE, QHP1, QMH, QN, QP, QX, QXBR, QXE, QXEK, QXHQ, QXK, SH, SH1, SHE, SM11, SWE2, SWX2, SX, SX1, SXC, SXC1, SXE, SXE1, VSP, VTE5, VX, VX1, VX1M, VXE, VXEM, VVK, VXU1
	16953-ZDK-003	-----	-	1	-----	LH, LH1, PX, QH, QH1, QHE, QMH, QN, QX, QXE, QXHQ, SH, SH1, SHE, SM11, SWX2, SX, SX1, SXC, SXC1, VTE5, VX, VX1, VX1M, VXE, VXEM
20	16954-ZE1-812	PLATE, LEVER SETTING	1	1	-----	LH, LH1, LH2, LHB5, LHP1, LXE9, PX, QA2, QBE1, QEBR, QH, QH1, QHB1, QHB3, QHB5, QHBR, QHE, QHP1, QMH, QN, QP, QX, QXBR, QXE, QXEK, QXHQ, QXK, SH, SH1, SHE, SM11, SWE2, SWX2, SX, SX1, SXC, SXC1, SXE, SXE1, VSP, VTE5, VX, VX1, VX1M, VXE, VXEM, VVK, VXU1
21	16956-ZE1-811	SPRING, COCK LEVER	1	1	-----	LH, LH1, LH2, LHB5, LHP1, LXE9, PX, QA2, QBE1, QEBR, QH, QH1, QHB1, QHB3, QHB5, QHBR, QHE, QHP1, QMH, QN, QP, QX, QXBR, QXE, QXEK, QXHQ, QXK, SH, SH1, SHE, SM11, SWE2, SWX2, SX, SX1, SXC, SXC1, SXE, SXE1, VSP, VTE5, VX, VX1, VX1M, VXE, VXEM, VVK, VXU1
22	16957-ZE1-812	PACKING, FUEL COCK	1	1	-----	LH, LH1, LH2, LHB5, LHP1, LXE9, PX, QA2, QBE1, QEBR, QH, QH1, QHB1, QHB3, QHB5, QHBR, QHE, QHP1, QMH, QN, QP, QX, QXBR, QXE, QXEK, QXHQ, QXK, SH, SH1, SHE, SM11, SWE2, SWX2, SX, SX1, SXC, SXC1, SXE, SXE1, VSP, VTE5, VX, VX1, VX1M, VXE, VXEM, VVK, VXU1
23	16967-ZE0-811	CUP, FUEL STRAINER	1	1	-----	LH, LH1, LH2, LHB5, LHP1, LXE9, PX, QA2, QBE1, QEBR, QH, QH1, QHB1, QHB3, QHB5, QHBR, QHE, QHP1, QMH, QN, QP, QX, QXBR, QXE, QXEK, QXHQ, QXK, SH, SH1, SHE, SM11, SWE2, SWX2, SX, SX1, SXC, SXC1, SXE, SXE1, VSP, VTE5, VX, VX1, VX1M, VXE, VXEM, VVK, VXU1
24	93500-03006-1H	SCREW, PAN, 3X6	2	2	-----	LH, LH1, LH2, LHB5, LHP1, LXE9, PX, QA2, QBE1, QEBR, QH, QH1, QHB1, QHB3, QHB5, QHBR, QHE, QHP1, QMH, QN, QP, QX, QXBR, QXE, QXEK, QXHQ, QXK, SH, SH1, SHE, SM11, SWE2, SWX2, SX, SX1, SXC, SXC1, SXE, SXE1, VSP, VTE5, VX, VX1, VX1M, VXE, VXEM, VVK, VXU1
25	94305-20122	PIN, SPRING, 2X12	1	1	-----	LH, LH1, LH2, LHB5, LHP1, LXE9, PX, QA2, QBE1, QEBR, QH, QH1, QHB1, QHB3, QHB5, QHBR, QHE, QHP1, QMH, QN, QP, QX, QXBR, QXE, QXEK, QXHQ, QXK, SH, SH1, SHE, SM11, SWE2, SWX2, SX, SX1, SXC, SXC1, SXE, SXE1, VSP, VTE5, VX, VX1, VX1M, VXE, VXEM, VVK, VXU1
26	99101-ZH8-0900	JET, MAIN, #90	(1)	-	-----	LH, LH1, LH2, LHB5, LHP1, LXE9, PX, QA2, QEBR, QH, QH1, QHB3, QHB5, QHBR, QHE, QHP1, QMH, QN, QX, QXBR, QXE, QXEK, QXHQ, QXK, SH, SH1, SHE, SM11, SX, SX1, SXC, SXC1, SXE, SXE1, VSP, VX, VX1, VX1M, VXE, VXEM, VVK, VXU1

E-14

CARBURETOR(1)

Ref. No.	Part No.	Description	Reqd. QTY		Serial No.	Parts catalogue code
			GX 390 H1	GX 390 H2		
26)	99101-ZH8-0880	JET, MAIN, #88	(1)	-		LH,LH1,LH2,LHB5,LHP1,LXE9,PX,QA2,QEBR,QH,QH1,QHB3,QHB5,QHBR,QHE,QHP1,QMH,QX,QXBR,QXE,QXEK,QXHQ,QXK,SH,SH1,SHE,SM11,SX,SX1,SXC,SXC1,SXE,SXE1
	99101-ZH8-0920	JET, MAIN, #92	1	-		LH,LH1,LH2,LHB5,LHP1,LXE9,PX,QA2,QEBR,QH,QH1,QHB3,QHB5,QHBR,QHE,QHP1,QMH,QX,QXBR,QXE,QXEK,QXHQ,QXK,SH,SH1,SHE,SM11,SX,SX1,SXC,SXC1,SXE,SXE1
	99101-ZH8-1000	JET, MAIN, #100	(1)	-		QBE1,QHB1,QP,SWE2,SWX2,VTE5
	99101-ZH8-1020	JET, MAIN, #102	(1)	-		QBE1,QHB1,QP,SWE2,SWX2,VTE5
	99101-ZH8-1050	JET, MAIN, #105	1	-		QBE1,QHB1,QP,SWE2,SWX2,VTE5
	99101-ZH8-0920	JET, MAIN, #92	(1)	-		QN,VSP,VX,VX1,VX1M,VXE,VXEM,VXK,VXU1
	99101-ZH8-0950	JET, MAIN, #95	1	-		QN,VSP,VX,VX1,VX1M,VXE,VXEM,VXK,VXU1
	99101-ZDK-1000	JET, MAIN, #100	-	(1)		LH,LH1,PX,QH,QH1,QHE,QMH,QN,QX,QXE,QXHQ,SH,SH1,SHE,SM11,SWX2,SX,SX1,SXC,SXC1,VTE5,VX,VX1,VX1M,VXE,VXEM
	99101-ZDK-1050	JET, MAIN, #105	-	(1)		LH,LH1,PX,QH,QH1,QHE,QMH,QN,QX,QXE,QXHQ,SH,SH1,SHE,SM11,SWX2,SX,SX1,SXC,SXC1,VTE5,VX,VX1,VX1M,VXE,VXEM
	99101-ZDK-1080	JET, MAIN, #108	-	1		LH,LH1,PX,QH,QH1,QHE,QMH,QN,QX,QXE,QXHQ,SH,SH1,SHE,SM11,SWX2,SX,SX1,SXC,SXC1,VTE5,VX,VX1,VX1M,VXE,VXEM
27	99204-ZA0-0450	JET SET, PILOT, #45	1	-		LH,LH1,LH2,LHB5,LHP1,LXE9,PX,QA2,QEBR,QH,QH1,QHB3,QHB5,QHBR,QHE,QHP1,QMH,QN,QX,QXBR,QXE,QXEK,QXHQ,QXK,SH,SH1,SHE,SM11,SX,SX1,SXC,SXC1,SXE,SXE1,VSP,VX,VX1,VX1M,VXE,VXEM,VXK,VXU1
	99204-ZA0-0400	JET SET, PILOT, #40	1	-		QBE1,QHB1,QP,SWE2,SWX2,VTE5
	99204-ZE0-0380	JET SET, PILOT, #38	-	1		LH,LH1,PX,QH,QH1,QHE,QMH,QN,QX,QXE,QXHQ,SH,SH1,SHE,SM11,SWX2,SX,SX1,SXC,SXC1,VTE5,VX,VX1,VX1M,VXE,VXEM
28	16010-ZE2-015	GASKET SET	1	-		QBE1,QHB1,QP,SWE2,SWX2,VTE5
29	16011-Z7E-701	VALVE SET, FLOAT (CARBURETOR NO.)	1	-		QHE,VX1M,VXEM
	“	“	1	-	BE85T B	QEBR,QHBR,QXBR
	“	“	1	-	BE88Q A	LH,LH1,LH2,LHB5,LHP1,LXE9,PX,QA2,QH,QH1,QHB3,QHB5,QHP1,QMH,QX,QXE,QXEK,QXHQ,QXK,SH,SH1,SHE,SM11,SX,SX1,SXC,SXC1,SXE,SXE1
	“	“	1	-		QN,VX,VX1,VXE,VXK,VXU1
	“	“	-	1		LH,LH1,PX,QH,QH1,QHE,QMH,QN,QX,QXE,QXHQ,SH,SH1,SHE,SM11,SWX2,SX,SX1,SXC,SXC1,VTE5,VX,VX1,VX1M,VXE,VXEM
30	16141-Z0S-003	WASHER, PLAIN(6.2X10.7 DRAIN)	1	-		LH,LH1,LH2,LHB5,LHP1,LXE9,PX,QA2,QBE1,QEBR,QH,QH1,QHB1,QHB3,QHB5,QHBR,QHE,QHP1,QMH,QN,QP,QX,QXBR,QXE,QXEK,QXHQ,QXK,SH,SH1,SHE,SM11,SWE2,SWX2,SX,SX1,SXC,SXC1,SXE,SXE1,VSP,VTE5,VX,VX1,VX1M,VXK,VXU1
			-	1		LH,LH1,PX,QH,QH1,QHE,QMH,QN,QX,QXE,QXHQ,SH,SH1,SHE,SM11,SWX2,SX,SX1,SXC,SXC1,VTE5,VX,VX1,VX1M,VXE,VXEM



E-14-1

CARBURETOR(2)

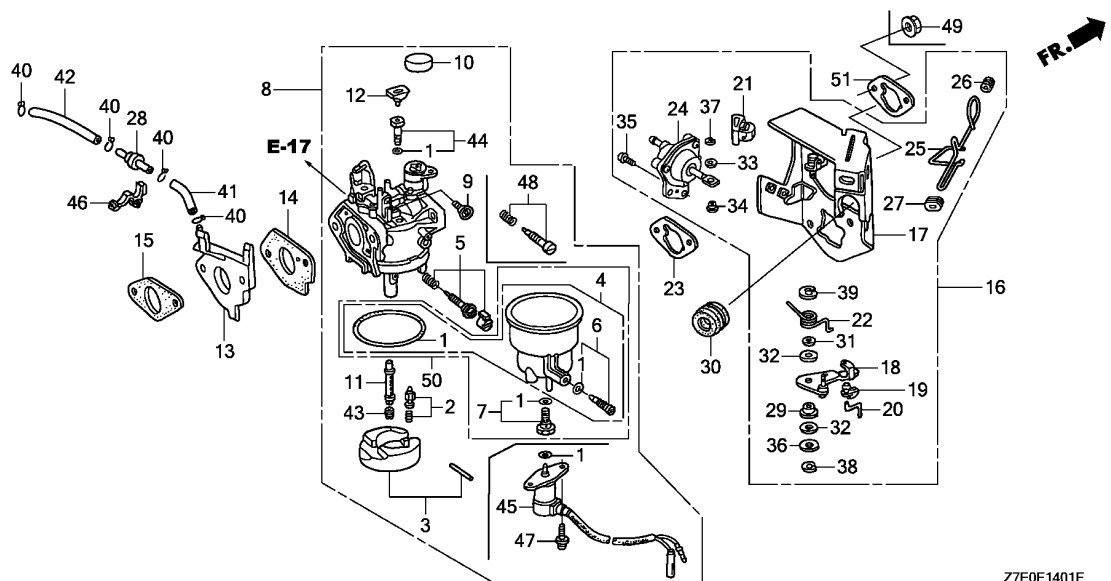

Ref. No.	L.O.N.	(Relative ref. Number) Description	F.R.T.
1	3111G1	GASKET SET, CARBURETOR(A) (3)	0.4
2	3111G6	FLOAT VALVE SET AND/OR FLOAT SET(A) (50)	0.4
4	3111M2	FLOAT CHAMBER SET AND/OR GASKET(A) (48)	0.4
5	3111D7	SCREW SET, PILOT	0.2
8	3111G7	CARBURETOR(A) (15)	0.3
13	3111G2	CARBURETOR INSULATOR AND/OR PACKING(A)	0.3
14	3111G5	PACKING, CARBURETOR(A)	0.3
16	8101R1	STAY, MANUAL CHOKE (51)	0.3
23	3121D9	PACKING, AIR CLEANER	0.2
	3121D9A	.Replace carburetor side add	0.1
24	3111A7	DIAPHRAGM, CARBURETOR	0.3
25	8101Q2	ROD, CHOKE CONTROL (41,42)	0.2
28	311175	VALVE, DASHPOT CHECK (11)	0.1
43	3111G4	JET, MAIN(A)	0.4
45	6211C0	VALVE, CARBURETOR SOLENOID	0.2

Z7E0E1401E

Ref. No.	Part No.	Description	Reqd. QTY		Serial No.	Parts catalogue code
			GX 390 H1	GX 390 H2		
1	16010-ZE3-701	GASKET SET	1	1	EDF6,EDS1,EDS2,EDT1,ES2,ES3S,ES4S,VMQ3,VMT3,VS4,VS6,VS4,VS6,VSB4,VXEK,VXKS	
	16010-ZA0-921	1	1	VPKK,VPX4,VPXB,VPXE,VPXJ,VPXK,VPXX	
2	16011-ZA0-931	VALVE SET, FLOAT	1	1	EDF6,EDS1,EDS2,EDT1,ES2,ES3S,ES4S,VMQ3,VMT3,VPKK,VPX4,VPXB,VPXE,VPXJ,VPXK,VPXX,VS4,VS6,VSB4,VXEK,VXKS	
3	16013-ZA0-931	FLOAT SET	1	-	EDF6,EDS1,EDS2,EDT1,ES3S,ES4S	
	16013-Z1C-003	1	-	ES2,VMQ3,VMT3,VPKK,VPX4,VPXB,VPXE,VPXJ,VPXK,VPXX,VS4,VS6,VSB4,VXEK,VXKS	
4	16015-ZA0-931	CHAMBER SET, FLOAT	1	-	EDS1,EDS2,EDT1,ES2,VPKK,VPXB,VPXE,VPXK,VPXX,VXEK,VXKS	
	16015-Z7B-D11	-	1	EDF6,EDS1,EDS2,EDT1,ES2,VXEK,VXKS	
5	16016-ZH8-W01	SCREW SET	1	-	EDF6,EDS1,EDS2,EDT1,ES2,ES3S,ES4S,VPKK,VPX4,VPXB,VPXE,VPXJ,VPXK,VPXX,VS4,VS6,VXEK,VXKS	
	16016-Z1E-V21	-	1	EDS1,EDS2,EDT1,ES2,VXEK,VXKS	
	16016-ZH8-W01	-	1	VPKK,VPXB,VPXE,VPXK,VPXX	
6	16024-124-760	SCREW SET, DRAIN	1	-	EDF6,ES2,ES3S,ES4S,VMQ3,VMT3,VPKK,VPX4,VPXB,VPXE,VPXJ,VPXK,VPXX,VS4,VS6,VSB4,VXEK,VXKS	
	16024-124-761	1	-	EDS1,EDS2,EDT1	
	16024-124-760	-	1	EDS1,EDS2,EDT1,ES2,VPKK,VPXB,VPXE,VPXK,VPXX,VXEK,VXKS	
7	16028-Z7E-E61	SCREW SET	1	-	EDF6	
	16028-ZA0-931	1	-	EDS1,EDS2,EDT1,ES2,ES3S,ES4S,VMQ3,VMT3,VS4,VS6,VSB4,VXEK,VXKS	
	16028-Z7E-E61	-	1	EDS1,EDS2,EDT1,ES2,VXEK,VXKS	
8	16100-ZF6-V42	CARBURETOR ASSY. (BE87G B)	1	-	EDF6	
	16100-ZF6-V41	CARBURETOR ASSY. (BE87G A)	1	-	EDS1,EDS2,EDT1	
	16100-Z7E-D11	CARBURETOR ASSY. (BE89J A)	1	-	ES2,VS4,VS6,VXEK,VXKS	
	16100-ZF6-743	CARBURETOR ASSY. (BE87A C)	1	-	ES3S,ES4S	
	16100-Z7E-D21	CARBURETOR ASSY. (BE89K A)	1	-	VMQ3,VMT3,VS4	
	16100-Z7F-814	CARBURETOR ASSY. (BE89L C)	1	-	VPKK,VPX4,VPXB,VPXE,VPXJ,VPXK,VPXX	
	16100-Z7E-961	CARBURETOR ASSY. (BE96E A)	-	1	EDS1,EDS2,EDT1	

E-14-1

CARBURETOR(2)

Ref. No.	Part No.	Description	Reqd. QTY		Serial No.	Parts catalogue code
			GX 390 H1	GX 390 H2		
(8)	16100-Z7E-951	CARBURETOR ASSY.(BE96F A) ...	-	1	-----	ES2,VXEK,VXKS
	16100-Z7E-941	CARBURETOR ASSY.(BE96D A) ...	-	1	-----	VPKK,VPXB,VPXE,VPXK,VPXX
9	16124-ZE0-005	SCREW, THROTTLE STOP	1	1	-----	EDF6,EDS1,EDS2,EDT1,ES2,ES3S,ES4S,VMQ3,VMT3,VPKK,VPX4,VPXB,VPXE,VPXJ VPXK,VPXX,VS4,VS6,VS4,VS6,VS4,VXEK,VXKS
10	16148-141-881	CAP, CHOKE DUST	1	1	-----	EDF6,EDS1,EDS2,EDT1,ES2,ES3S,ES4S,VMQ3,VMT3,VPKK,VPX4,VPXB,VPXE,VPXJ VPXK,VPXX,VS4,VS6,VS4,VXEK,VXKS
11	16166-ZF6-005	NOZZLE, MAIN	1	-	-----	EDF6,EDS1,EDS2,EDT1,ES2,ES3S,ES4S,VMQ3,VMT3,VPKK,VPX4,VPXB,VPXE,VPXJ VPXK,VPXX,VS4,VS6,VS4,VXEK,VXKS
	16166-Z7E-951	-	1	-----	EDS1,EDS2,EDT1,ES2,VXEK,VXKS
	16166-Z7E-941	-	1	-----	VPKK,VPXB,VPXE,VPXK,VPXX
12	16172-ZE3-W10	COLLAR, SETTING	1	1	-----	EDF6,EDS1,EDS2,EDT1,ES2,ES3S,ES4S,VMQ3,VMT3,VPKK,VPX4,VPXB,VPXE,VPXJ VPXK,VPXX,VS4,VS6,VS4,VXEK,VXKS
13	16211-Z7E-700	INSULATOR, CARBURETOR	1	-	-----	EDF6,EDS2,ES2,ES3S,ES4S,VMQ3,VMT3,VPKK,VPXB,VPXE,VPXJ,VPXK,VPXX,VS4 VS6,VS4,VXEK,VXKS
	16211-ZF6-D40	1	-	0002756	EDS1,EDT1
			1	-	0009628	VPX4
	16211-Z7E-700	1	-	0002757	EDS1,EDT1
			1	-	0009629	VPX4
	16211-ZBH-700	-	1	-----	EDS1,EDS2,EDT1,ES2,VPKK,VPXB,VPXE,VPXK,VPXX,VXEK,VXKS
14	16221-Z7E-701	PACKING, CARBURETOR (NINGBO SIL GASKET)	1	1	-----	EDF6,EDS1,EDS2,EDT1,ES2,ES3S,ES4S,VMQ3,VMT3,VPKK,VPX4,VPXB,VPXE,VPXJ VPXK,VPXX,VS4,VS6,VS4,VXEK,VXKS
	16221-ZF6-800	PACKING, CARBURETOR	1	-	-----	EDF6,EDS1,EDS2,EDT1,ES2,ES3S,ES4S,VMQ3,VMT3,VPKK,VPX4,VPXB,VPXE,VPXJ VPXK,VPXX,VS4,VS6,VS4,VXEK,VXKS
	16221-Z5T-000	-	1	-----	EDS1,EDS2,EDT1,ES2,VPKK,VPXB,VPXE,VPXK,VPXX,VXEK,VXKS
15	16212-Z7E-701	PACKING, INSULATOR (NINGBO SIL GASKET)	1	-	-----	EDF6,EDS1,EDS2,EDT1,ES2,ES3S,ES4S,VMQ3,VMT3,VPKK,VPX4,VPXB,VPXE,VPXJ VPXK,VPXX,VS4,VS6,VS4,VXEK,VXKS
	16223-ZE3-W00	PACKING, INSULATOR	1	-	-----	EDF6,EDS1,EDS2,EDT1,ES2,ES3S,ES4S,VMQ3,VMT3,VPKK,VPX4,VPXB,VPXE,VPXJ VPXK,VPXX,VS4,VS6,VS4,VXEK,VXKS
	16212-Z5T-000	PACKING, CARBURETOR INSULATOR	-	1	-----	EDS1,EDS2,EDT1,ES2,VPKK,VPXB,VPXE,VPXK,VPXX,VXEK,VXKS
16	16260-Z7E-000	STAY ASSY., MANUAL CHOKE	1	-	-----	EDF6,EDS2,VPKK,VPXB,VPXE,VPXJ,VPXK,VPXX,VXEK,VXKS
	16260-Z7E-800	1	-	-----	ES2,ES3S,ES4S,VMQ3,VMT3,VS4,VS6,VS4
	16260-ZE3-D22	1	-	-----	VPX4
	16260-ZE2-723	1	-	0000670	EDS1
	16260-ZE3-D22	1	-	0002756	EDT1
	16260-Z7E-800	1	-	0000671	EDS1
	16260-Z7E-000	1	-	0002757	EDT1
	16260-Z7E-800	-	1	-----	EDS1,ES2
	16260-Z7E-000	-	1	-----	EDS2,EDT1,VPKK,VPXB,VPXE,VPXK,VPXX,VXEK,VXKS
17	16261-ZE2-702	STAY COMP., SOLENOID	1	1	-----	EDF6,EDS1,EDS2,EDT1,ES2,ES3S,ES4S,VMQ3,VMT3,VPKK,VPX4,VPXB,VPXE,VPXJ VPXK,VPXX,VS4,VS6,VS4,VXEK,VXKS
18	16262-ZE2-711	LEVER, CHOKE	1	1	-----	EDF6,EDS1,EDS2,EDT1,ES2,ES3S,ES4S,VMQ3,VMT3,VPKK,VPX4,VPXB,VPXE,VPXJ VPXK,VPXX,VS4,VS6,VS4,VXEK,VXKS
19	16263-Z7B-000	JOINT, ROD	1	-	-----	EDF6,EDS2,ES2,ES3S,ES4S,VMQ3,VMT3,VPKK,VPXB,VPXE,VPXJ,VPXK,VPXX,VS4 VS6,VS4,VXEK,VXKS
	16263-ZA0-000	1	-	-----	VPX4
			1	-	0002756	EDS1,EDT1
	16263-Z7B-000	1	-	0002757	EDS1,EDT1
			-	1	-----	EDS1,EDS2,EDT1,ES2,VPKK,VPXB,VPXE,VPXK,VPXX,VXEK,VXKS
20	16264-ZE2-701	ROD, CHOKE	1	1	-----	EDF6,EDS1,EDS2,EDT1,ES2,ES3S,ES4S,VMQ3,VMT3,VPKK,VPX4,VPXB,VPXE,VPXJ VPXK,VPXX,VS4,VS6,VS4,VXEK,VXKS
21	16265-Z7E-000	STOPPER, CHOKE ROD	1	-	-----	EDF6,EDS2,ES2,ES3S,ES4S,VMQ3,VMT3,VPKK,VPXB,VPXE,VPXJ,VPXK,VPXX,VS4 VS6,VS4,VXEK,VXKS

2

E-14-1

CARBURETOR(2)

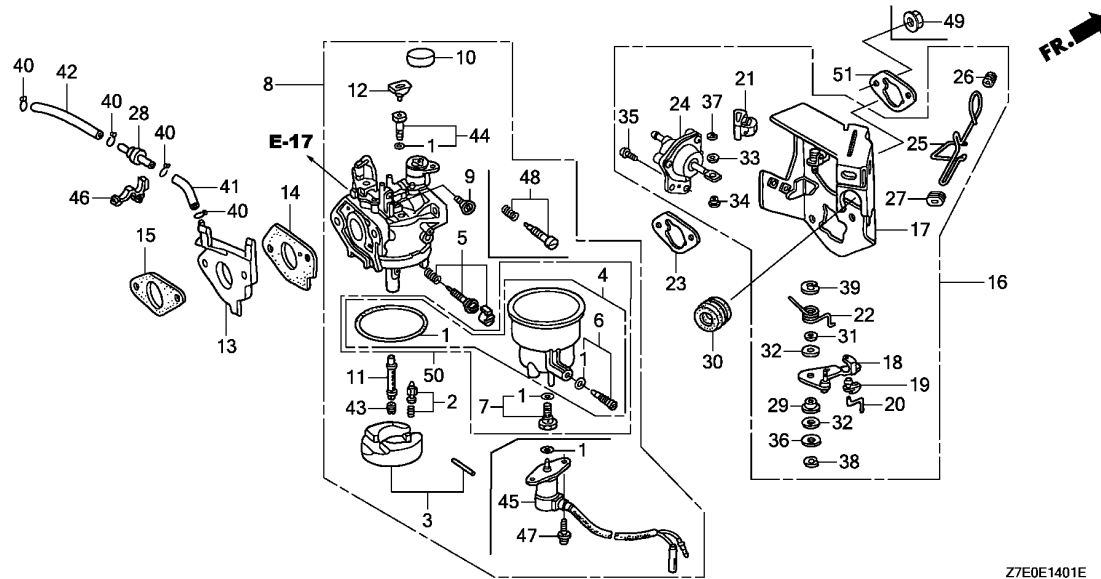

Z7E0E1401E

Ref. No.	Part No.	Description	Reqd. QTY		Serial No.	Parts catalogue code
			GX 390 H1	GX 390 H2		
21)	16265-ZE2-721	STOPPER, CHOKE ROD	1	-	-----	VPX4
	16265-Z7E-000	-----	1	-	0002756	EDS1,EDT1
		-----	1	-	0002757	EDS1,EDT1
		-----	-	1	-----	EDS1,EDS2,EDT1,ES2,VPKK,VPXB,VPXE,VPXK,VPXX,VXEK,VXKS
22	16268-ZE2-721	SPRING, MANUAL CHOKE	1	1	-----	EDF6,EDS1,EDS2,EDT1,ES2,ES3S,ES4S,VMQ3,VMT3,VPKK,VPX4,VPXB,VPXE,VPXJ
23	17228-Z5T-000	PACKING, AIR CLEANER	1	1	-----	VPXK,VPXX,VS4,VS6,VS4,VS6,VS4,VS6,VXEK,VXKS
24	16400-ZE2-704	DIAPHRAGM ASSY.	1	1	-----	EDF6,EDS1,EDS2,EDT1,ES2,ES3S,ES4S,VMQ3,VMT3,VPKK,VPX4,VPXB,VPXE,VPXJ
25	16611-ZE3-D21	ROD, CHOKE CONTROL	1	1	-----	VPXK,VPXX,VS4,VS6,VS4,VS6,VXEK,VXKS
	16611-ZE2-711	-----	1	1	-----	EDF6,EDS2,EDT1,VPKK,VPX4,VPXB,VPXE,VPXJ,VPXK,VPXX,VXEK,VXKS
		-----	1	1	-----	EDS1,ES2,ES3S,ES4S,VMQ3,VMT3,VS4,VS6,VS4
26	16613-893-000	GROMMET, CHOKE ROD	1	1	-----	EDF6,EDS1,EDS2,EDT1,ES2,ES3S,ES4S,VMQ3,VMT3,VPKK,VPX4,VPXB,VPXE,VPXJ
		-----	1	1	-----	VPXK,VPXX,VS4,VS6,VS4,VS6,VXEK,VXKS
27	16615-893-000	GUIDE, CHOKE ROD	1	1	-----	EDF6,EDS1,EDS2,EDT1,ES2,ES3S,ES4S,VMQ3,VMT3,VPKK,VPX4,VPXB,VPXE,VPXJ
		-----	1	1	-----	VPXK,VPXX,VS4,VS6,VS4,VS6,VXEK,VXKS
28	36135-ZF6-D41	VALVE, DASHPOT CHECK	1	1	-----	EDF6,EDS1,EDS2,EDT1,ES2,ES3S,ES4S,VMQ3,VMT3,VPKK,VPX4,VPXB,VPXE,VPXJ
		-----	1	1	-----	VPXK,VPXX,VS4,VS6,VS4,VS6,VXEK,VXKS
29	53149-964-003	BUSH, ARM PIVOT	1	1	-----	EDF6,EDS1,EDS2,EDT1,ES2,ES3S,ES4S,VMQ3,VMT3,VPKK,VPX4,VPXB,VPXE,VPXJ
		-----	1	1	-----	VPXK,VPXX,VS4,VS6,VS4,VS6,VXEK,VXKS
30	88911-MJ3-000	GROMMET, FENDER	1	1	-----	EDF6,EDS1,EDS2,EDT1,ES2,ES3S,ES4S,VMQ3,VMT3,VPKK,VPX4,VPXB,VPXE,VPXJ
		-----	1	1	-----	VPXK,VPXX,VS4,VS6,VS4,VS6,VXEK,VXKS
31	90431-ZE2-700	WASHER, CHOKE LEVER	1	1	-----	EDF6,EDS1,EDS2,EDT1,ES2,ES3S,ES4S,VMQ3,VMT3,VPKK,VPX4,VPXB,VPXE,VPXJ
		-----	1	1	-----	VPXK,VPXX,VS4,VS6,VS4,VS6,VXEK,VXKS
32	90432-ZE2-700	SEAL, CHOKE LEVER	2	2	-----	EDF6,EDS1,EDS2,EDT1,ES2,ES3S,ES4S,VMQ3,VMT3,VPKK,VPX4,VPXB,VPXE,VPXJ
		-----	2	2	-----	VPXK,VPXX,VS4,VS6,VS4,VS6,VXEK,VXKS

E-14-1

CARBURETOR(2)

Ref. No.	Part No.	Description	Reqd. QTY		Serial No.	Parts catalogue code
			GX 390 H1	GX 390 H2		
33	90433-ZE2-700	WASHER, THRUST, 2.7X8	1	1	-----	EDF6,EDS1,EDS2,EDT1,ES2,ES3S,ES4S,VMQ3,VMT3,VPKK,VPX4,VPXB,VPXE,VPXJ VPXK,VPXX,VS4,VS6,VS4,VS6,VS4,VS6,VXEK,VXKS
34	90434-ZE2-700	COLLAR, LEVER	1	1	-----	EDF6,EDS1,EDS2,EDT1,ES2,ES3S,ES4S,VMQ3,VMT3,VPKK,VPX4,VPXB,VPXE,VPXJ VPXK,VPXX,VS4,VS6,VS4,VS6,VXEK,VXKS
35	93500-05012-0A	SCREW, PAN, 5X12	2	2	-----	EDF6,EDS1,EDS2,EDT1,ES2,ES3S,ES4S,VMQ3,VMT3,VPKK,VPX4,VPXB,VPXE,VPXJ VPXK,VPXX,VS4,VS6,VS4,VS6,VXEK,VXKS
36	94103-05000	WASHER, PLAIN, 5MM	1	1	-----	EDF6,EDS1,EDS2,EDT1,ES2,ES3S,ES4S,VMQ3,VMT3,VPKK,VPX4,VPXB,VPXE,VPXJ VPXK,VPXX,VS4,VS6,VS4,VS6,VXEK,VXKS
37	90601-27E-000	E-RING, 2MM	1	-	-----	EDF6,EDS2,ES2,ES3S,ES4S,VMQ3,VMT3,VPKK,VPXB,VPXE,VPXJ,VPXK,VPXX,VS4 VS6,VS4,VXEK,VXKS
	94540-02010	1	-	-----	VPX4
	90601-27E-000	1	-	0000669	EDS1,EDT1
		-	1	-----	EDS1,EDT1
38	90602-27E-000	E-RING, 4MM	1	-	-----	EDS1,EDS2,EDT1,ES2,VPKK,VPXB,VPXE,VPXK,VPXX,VXEK,VXKS
	94540-04010	1	-	-----	EDF6,EDS2,ES2,ES3S,ES4S,VMQ3,VMT3,VPKK,VPXB,VPXE,VPXJ,VPXK,VPXX,VS4 VS6,VS4,VXEK,VXKS
	90602-27E-000	1	-	0000669	EDS1,EDT1
		-	1	-----	EDS1,EDT1
		-	1	-----	EDS1,EDS2,EDT1,ES2,VPKK,VPXB,VPXE,VPXK,VPXX,VXEK,VXKS
39	90603-27E-000	E-RING, 7MM	1	-	-----	EDF6,EDS2,ES2,ES3S,ES4S,VMQ3,VMT3,VPKK,VPXB,VPXE,VPXJ,VPXK,VPXX,VS4 VS6,VS4,VXEK,VXKS
	94540-07010	1	-	-----	VPX4
	90603-27E-000	1	-	0000669	EDS1,EDT1
		-	1	-----	EDS1,EDT1
		-	1	-----	EDS1,EDS2,EDT1,ES2,VPKK,VPXB,VPXE,VPXK,VPXX,VXEK,VXKS
40	95002-02070	CLIP, TUBE(B7)	4	4	-----	EDF6,EDS1,EDS2,EDT1,ES2,ES3S,ES4S,VMQ3,VMT3,VPKK,VPX4,VPXB,VPXE,VPXJ VPXK,VPXX,VS4,VS6,VS4,VS6,VXEK,VXKS
41	95005-35075-10	TUBE, 3.5X75(95005-35001-10M)	1	1	-----	EDF6,EDS1,EDS2,EDT1,ES2,ES3S,ES4S,VMQ3,VMT3,VPKK,VPX4,VPXB,VPXE,VPXJ VPXK,VPXX,VS4,VS6,VS4,VS6,VXEK,VXKS
42	95005-35130-10	TUBE, 3.5X130(95005-35001-10M)	1	1	-----	EDF6,EDS1,EDS2,EDT1,ES2,ES3S,ES4S,VMQ3,VMT3,VPKK,VPX4,VPXB,VPXE,VPXJ VPXK,VPXX,VS4,VS6,VS4,VS6,VXEK,VXKS
43	99101-ZH8-0980	JET, MAIN, #98	(1)	-	-----	EDF6,EDS1,EDS2,EDT1,ES2,ES3S,ES4S,VMQ3,VMT3,VS4,VS6,VS4,VS6,VXEK,VXKS
	99101-ZH8-1000	JET, MAIN, #100	(1)	-	-----	EDF6,EDS1,EDS2,EDT1,ES2,ES3S,ES4S,VMQ3,VMT3,VS4,VS6,VS4,VS6,VXEK,VXKS
	99101-ZH8-1020	JET, MAIN, #102	(1)	-	-----	EDF6,EDS1,EDS2,EDT1,ES2,ES3S,ES4S,VMQ3,VMT3,VS4,VS6,VS4,VS6,VXEK,VXKS
	99101-ZH8-1050	JET, MAIN, #105	(1)	-	-----	EDF6,EDS1,EDS2,EDT1,VPKK,VPX4,VPXB,VPXE,VPXJ,VPXK,VPXX
	99101-ZH8-1020	JET, MAIN, #102	(1)	-	-----	VPKK,VPX4,VPXB,VPXE,VPXJ,VPXK,VPXX
	99101-ZH8-1080	JET, MAIN, #108	1	-	-----	VPKK,VPX4,VPXB,VPXE,VPXJ,VPXK,VPXX
	99101-ZDK-0920	JET, MAIN, #92	-	(1)	-----	EDS1,EDS2,EDT1,ES2,VXEK,VXKS
	99101-ZDK-0980	JET, MAIN, #98	-	(1)	-----	EDS1,EDS2,EDT1,ES2,VXEK,VXKS
	99101-ZDK-1000	JET, MAIN, #100	-	1	-----	EDS1,EDS2,EDT1,ES2,VXEK,VXKS
		-	(1)	-----	VPKK,VPXB,VPXE,VPXK,VPXX
	99101-ZDK-1050	JET, MAIN, #105	-	(1)	-----	VPKK,VPXB,VPXE,VPXK,VPXX
	99101-ZDK-1080	JET, MAIN, #108	-	1	-----	VPKK,VPXB,VPXE,VPXK,VPXX
44	99204-ZA0-0450	JET SET, PILOT, #45	1	-	-----	EDF6,EDS1,EDS2,EDT1,ES2,ES3S,ES4S,VMQ3,VMT3,VPKK,VPX4,VPXB,VPXE,VPXJ VPXK,VPXX,VS4,VS6,VS4,VS6,VXEK,VXKS
	99204-ZE0-0450	-	1	-----	EDS1,EDS2,EDT1,ES2,VPKK,VPXB,VPXE,VPXK,VPXX,VXEK,VXKS
45	16230-ZE3-702	VALVE ASSY., SOLENOID	1	1	-----	EDF6,EDS1,EDS2,EDT1,ES2,ES3S,ES4S,VMQ3,VMT3,VS4,VS6,VS4,VS6,VXEK,VXKS
46	90650-SD9-003	CLIP, WIRE HARNESS	1	1	-----	EDF6,EDS1,EDS2,EDT1,ES2,ES3S,ES4S,VMQ3,VMT3,VS4,VS6,VS4,VS6,VXEK,VXKS
47	93892-05012-18	SCREW-WASHER, 5X12	2	2	-----	EDF6,EDS1,EDS2,EDT1,ES2,ES3S,ES4S,VMQ3,VMT3,VS4,VS6,VS4,VS6,VXEK,VXKS
48	16016-ZF6-D40	SCREW SET	1	-	-----	VMQ3,VMT3,VS4
49	94050-06000	NUT, FLANGE, 6MM	2	-	-----	ES2,VMQ3,VMT3,VS4,VS6,VS4
50	06160-Z7F-315	BOLT KIT, FUEL CHAMBER	1	-	-----	VPKK,VPX4,VPXB,VPXE,VPXJ,VPXX,VXEK,VXKS
	06160-Z7F-305	1	-	-----	VPXK
51	17228-Z5T-000	PACKING, AIR CLEANER	1	-	-----	EDF6,EDS1,EDS2,EDT1,ES2,ES3S,ES4S,VMQ3,VMT3,VPKK,VPX4,VPXB,VPXE,VPXJ VPXK,VPXX,VS4,VS6,VS4,VS6,VXEK,VXKS
	16220-ZA0-702	SPACER COMP., CARBURETOR	-	1	-----	EDS1,EDS2,EDT1,ES2,VPKK,VPXB,VPXE,VPXK,VPXX,VXEK,VXKS



E-15

AIR CLEANER(1)

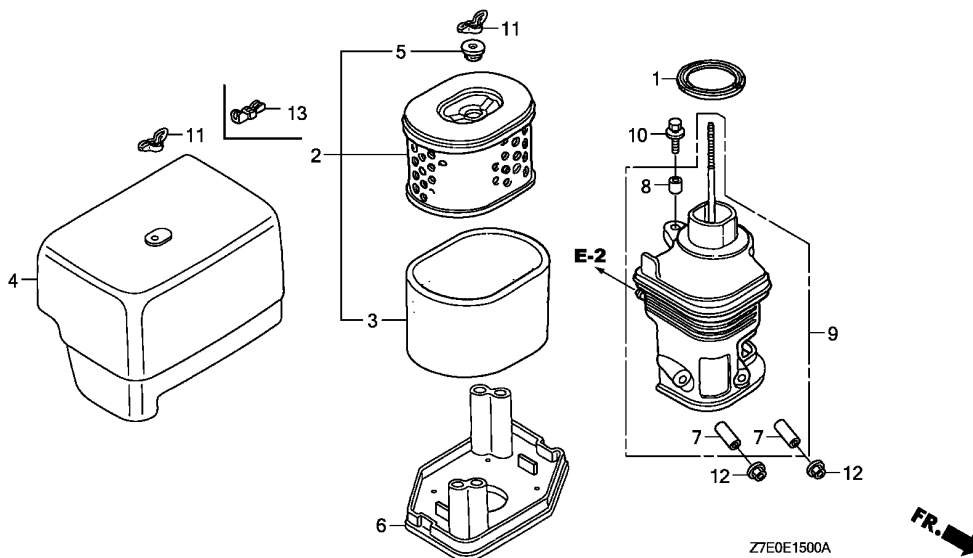

Ref. No.	L.O.N.	(Relative ref. Number) Description	F.R.T.
1	3121E1	PACKING, ELBOW	0.1
2	3121B8	ELEMENT, AIR CLEANER	0.1
		.INCLUDES: Air cleaner element -inspection	
3	3121C1	FILTER, OUTER	0.1
		.INCLUDES: Outer filter-inspection	
6	3121D6	NOSE, SILENCER	0.1
9	3121B4	ELBOW, AIR CLEANER	0.1

Ref. No.	Part No.	Description	Reqd. QTY		Serial No.	Parts catalogue code
			GX 390 H1	GX 390 H2		
1	17417-Z7E-003	PACKING, AIR CLEANER ELBOW ..	1	-	-----	LH1, LH2, LHB5, LHP1, LXE9, PX, QEBR, QH1, QHB3, QHB5, QHBR, QHE, QHP1, QMH, QN, QX QXBR, QXE, QXEK, QXK, SH1, SX1, SXC1, SXE1, VTE5, VX1, VX1M, VXE, VXEM, VXX, VXU1
	16271-ZE2-010	PACKING, ELBOW	1	-	-----	QA2, QH, QXHQ, SH, SM11, SX, VSP, VX
	17417-Z7E-003	PACKING, AIR CLEANER ELBOW ..	1	-	0146692	LH, SHE, SXC, SXE
2	17210-Z7E-003	ELEMENT COMP., AIR CLEANER ..	1	-	-----	LH1, LH2, LHB5, LHP1, LXE9, PX, QEBR, QH1, QHB3, QHB5, QHBR, QHE, QHP1, QMH, QN, QX QXBR, QXE, QXEK, QXK, SH1, SX1, SXC1, SXE1, VTE5, VX1, VX1M, VXE, VXEM, VXX, VXU1
	17210-ZE3-010	ELEMENT, AIR CLEANER	1	-	-----	QA2, QH, QXHQ, SH, SM11, SX, VSP, VX
	17210-Z7E-003	ELEMENT COMP., AIR CLEANER ..	1	-	0146692	LH, SHE, SXC, SXE
	17218-ZE3-000	FILTER, OUTER	1	-	-----	LH, QA2, QH, QXHQ, SH, SHE, SM11, SX, SXC, SXE, VSP, VX
4	17231-Z7E-003	COVER, AIR CLEANER	1	-	-----	LH1, LH2, LHB5, LHP1, LXE9, PX, QEBR, QH1, QHB3, QHB5, QHBR, QHE, QHP1, QMH, QN, QX QXBR, QXE, QXEK, QXK, SH1, SX1, SXC1, SXE1, VTE5, VX1, VX1M, VXE, VXEM, VXX, VXU1
	17231-ZE3-W01	1	-	-----	QA2, QH, QXHQ, SH, SM11, SX, VSP, VX
	17231-Z7E-003	1	-	0146692	LH, SHE, SXC, SXE
5	17232-Z1V-601	GROMMET, AIR CLEANER	1	-	-----	LH1, LH2, LHB5, LHP1, LXE9, PX, QEBR, QH1, QHB3, QHB5, QHBR, QHE, QHP1, QMH, QN, QX QXBR, QXE, QXEK, QXK, SH1, SX1, SXC1, SXE1, VTE5, VX1, VX1M, VXE, VXEM, VXX, VXU1
	17232-891-000	1	-	-----	QA2, QH, QXHQ, SH, SM11, SX, VSP, VX
	17232-Z1V-601	1	-	0146692	LH, SHE, SXC, SXE
6	17235-Z7E-003	NOSE, SILENCER	1	-	-----	LH1, LH2, LHB5, LHP1, LXE9, PX, QEBR, QH1, QHB3, QHB5, QHBR, QHE, QHP1, QMH, QN, QX QXBR, QXE, QXEK, QXK, SH1, SX1, SXC1, SXE1, VTE5, VX1, VX1M, VXE, VXEM, VXX, VXU1
	17235-ZH9-N01	1	-	-----	QA2, QH, QXHQ, SH, SM11, SX, VSP, VX
	17235-Z7E-003	1	-	0146692	LH, SHE, SXC, SXE
7	17238-Z7B-003	COLLAR, AIR CLEANER	2	-	-----	LH1, LH2, LHB5, LHP1, LXE9, PX, QEBR, QH1, QHB3, QHB5, QHBR, QHE, QHP1, QMH, QN, QX QXBR, QXE, QXEK, QXK, SH1, SX1, SXC1, SXE1, VTE5, VX1, VX1M, VXE, VXEM, VXX, VXU1

E-15

AIR CLEANER(1)

Ref. No.	Part No.	Description	Reqd. QTY		Serial No.	Parts catalogue code
			GX 390 H1	GX 390 H2		
(7)	17238-ZE2-310	COLLAR, AIR CLEANER	2	-	-----	QA2,QH,QXHQ,SH,SM11,SX,VSP,VX
	17238-Z7B-003	2	-	0146691	LH,SHE,SXC,SXE
8	17239-Z1T-601	COLLAR B, AIR CLEANER (ZHEJIANG HENGB0)	1	-	-----	LH,SHE,SXC,SXE
	17239-ZE1-000	COLLAR B, AIR CLEANER	1	-	-----	LH1,LH2,LHB5,LHP1,LXE9,PX,QEBR,QH1,QHB3,QHB5,QHBR,QHE,QHP1,QMH,QN,QX,QXBR,QXE,QXEK,QXK,SH1,SX1,SXC1,SXE1,VTE5,VX1,VX1M,VXE,VXEM,VXK,VXU1
	17239-Z1T-601	COLLAR B, AIR CLEANER (ZHEJIANG HENGB0)	1	-	0146691	QA2,QH,QXHQ,SH,SM11,SX,VSP,VX
	17239-Z1T-601	COLLAR B, AIR CLEANER (ZHEJIANG HENGB0)	1	-	0146692	LH,SHE,SXC,SXE
9	17410-ZH9-N01	ELBOW COMP., AIR CLEANER	1	-	-----	QA2
	17410-Z7E-013	1	-	-----	QHE,VX1M,VXEM
	17410-ZH9-N00	1	-	0146691	LH,SHE,SXC,SXE
	17410-Z7E-003	1	-	0325786	QH,QXHQ,SH,SM11,SX,VSP,VX
	17410-Z7E-003	1	-	0351329	LH1,LH2,LHB5,LHP1,LXE9,PX,QEBR,QH1,QHB3,QHB5,QHBR,QHP1,QMH,QN,QX,QXBR,QXE,QXEK,QXK,SH1,SX1,SXC1,SXE1,VTE5,VX1,VXE,VXK,VXU1
	17410-ZH9-N01	1	-	0146692	0351329 LH,SHE,SXC,SXE
	17410-Z7E-013	1	-	0325787	QH,QXHQ,SH,SM11,SX,VSP,VX
	17410-Z7E-013	1	-	0351330	LH,LH1,LH2,LHB5,LHP1,LXE9,PX,QEBR,QH1,QHB3,QHB5,QHBR,QHP1,QMH,QN,QX,QXBR,QXE,QXEK,QXK,SH1,SHE,SX1,SXC,SXC1,SXE,SXE1,VTE5,VX1,VXE,VXK,VXU1
10	90009-ZE2-003	BOLT-WASHER, 6X22	1	-	-----	LH,QA2,QH,QHE,QXHQ,SH,SHE,SM11,SX,SXC,SXE,VX
	90009-Z1C-000	1	-	-----	LH1,LH2,LHB5,LHP1,LXE9,PX,QEBR,QH1,QHB3,QHB5,QHBR,QHP1,QMH,QN,QX,QXBR,QXE,QXEK,QXK,SH1,SX1,SXC1,SXE1,VTE5,VX1,VX1M,VXE,VXEM,VXK,VXU1
	90009-ZE2-003	1	-	0000517	VSP
	90009-ZE2-003	1	-	0000518	VSP
11	90201-Z1T-601	NUT, TOOL BOX SETTING (ZHEJIANG HENGB0)	2	-	-----	LH1,LH2,LHB5,LHP1,LXE9,PX,QEBR,QH1,QHB3,QHB5,QHBR,QHE,QHP1,QMH,QN,QX,QXBR,QXE,QXEK,QXK,SH1,SX1,SXC1,SXE1,VTE5,VX1,VX1M,VXE,VXEM,VXK,VXU1
	90325-044-000	NUT, TOOL BOX SETTING	1	-	-----	QA2
	90325-044-000	NUT, TOOL BOX SETTING	2	-	-----	QH,QXHQ,SH,SM11,SX,VSP,VX
	90201-Z1T-601	NUT, TOOL BOX SETTING (ZHEJIANG HENGB0)	2	-	0146691	LH,SHE,SXC,SXE
	90201-Z1T-601	NUT, TOOL BOX SETTING (ZHEJIANG HENGB0)	2	-	0146692	LH,SHE,SXC,SXE
12	94050-06000	NUT, FLANGE, 6MM	2	-	-----	LH,LH1,LH2,LHB5,LHP1,LXE9,PX,QA2,QEBR,QH,QH1,QHB3,QHB5,QHBR,QHE,QHP1,QMH,QN,QX,QXBR,QXE,QXEK,QXHQ,QXK,SH,SH1,SHE,SM11,SX,SX1,SXC,SXC1,SXE,SXE1,VSP,VTE5,VX,VX1,VX1M,VXE,VXEM,VXK,VXU1
13	90203-ZA0-800	NUT, WING, 6MM(BLACK)	1	-	-----	QA2

2

E-15-1

AIR CLEANER(2)

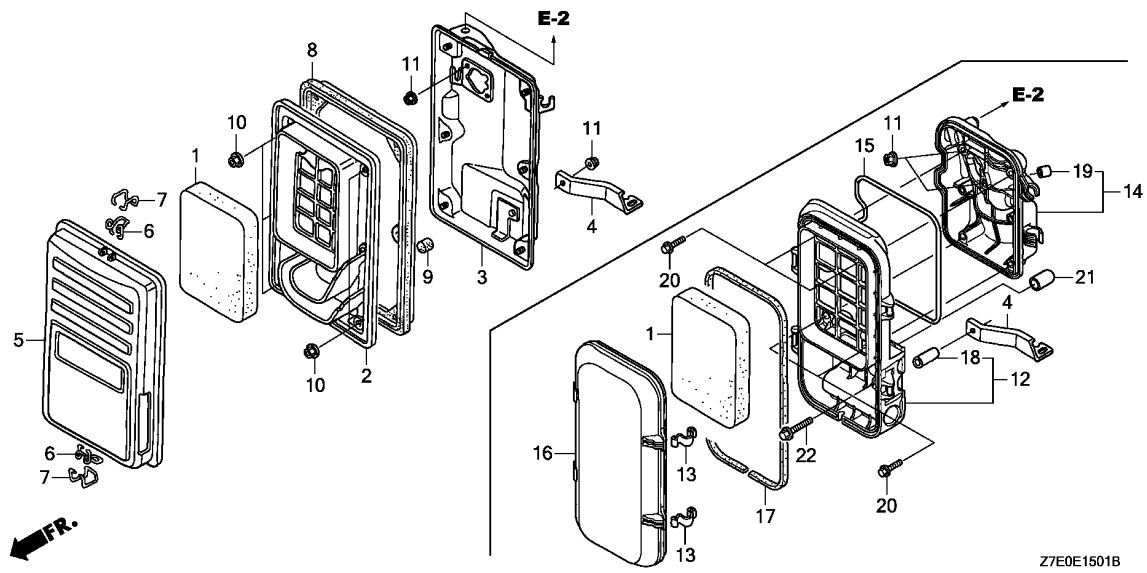

Ref. No.	L.O.N.	(Relative ref. Number) Description	F.R.T.
1	3121B8	ELEMENT, AIR CLEANERINCLUDES: Air cleaner element -inspection	0.1
2	3121F0	SEPARATOR, AIR CLEANER (12)	0.1
3	3121A5	CASE, AIR CLEANER	0.2
8	3121E8	SEAL, AIR CLEANER CASE	0.1
14	3121Q0	BASE, AIR CLEANER	0.2
15	3121R4	SEAL, AIR CLEANER CASE(A)	0.2
17	3121E9	SEAL, AIR CLEANER COVER	0.1

Ref. No.	Part No.	Description	Reqd. QTY		Serial No.	Parts catalogue code
			GX 390 H1	GX 390 H2		
1	17211-899-000	ELEMENT, AIR CLEANER	1	-	-----	EDF6,EDS1,EDS2,EDT1,ES3S,ES4S,VPKK,VPX4,VPXB,VPXE,VPXJ,VPXK,VPXX,VXEK VXKS
2	17212-ZB4-003	SEPARATOR, AIR CLEANER	1	-	-----	EDS1,EDS2,EDT1,ES2,VPKK,VPXB,VPXE,VPXK,VPXX,VXEK,VXKS
3	17220-ZB4-013	CASE COMP., AIR CLEANER	1	-	-----	EDF6,EDS2,VPKK,VPXJ,VPXK,VPXX,VXEK,VXKS
	17220-ZB4-003	1	-	0361369	EDS1,EDT1,ES3S,ES4S,VPX4,VPXB,VPXE
	17220-ZB4-013	1	-	0361370	EDS1,EDT1,ES3S,ES4S,VPX4,VPXB,VPXE
4	17222-ZC2-000	STAY, AIR CLEANER	1	-	-----	EDF6,EDS1,EDS2,EDT1,ES3S,ES4S,VPKK,VPX4,VPXB,VPXE,VPXJ,VPXK,VPXX,VXEK VXKS
	17222-Z23-H60	-	1	-----	EDS1,EDS2,EDT1,ES2,VPKK,VPXB,VPXE,VPXK,VPXX,VXEK,VXKS
	17222-ZC2-000	-	1	-----	EDS1,EDS2,EDT1,ES2,VPKK,VPXB,VPXE,VPXK,VPXX,VXEK,VXKS
5	17231-899-000	COVER COMP., AIR CLEANER	1	-	-----	EDF6,EDS1,EDS2,EDT1,ES3S,ES4S,VPKK,VPX4,VPXB,VPXE,VPXJ,VPXK,VPXX,VXEK VXKS
6	17235-899-000	CLIP A, AIR CLEANER WIRE	2	-	-----	EDF6,EDS1,EDS2,EDT1,ES3S,ES4S,VPKK,VPX4,VPXB,VPXE,VPXJ,VPXK,VPXX,VXEK VXKS
7	17236-899-000	CLIP B, AIR CLEANER WIRE	2	-	-----	EDF6,EDS1,EDS2,EDT1,ES3S,ES4S,VPKK,VPX4,VPXB,VPXE,VPXJ,VPXK,VPXX,VXEK VXKS
8	17252-899-000	SEAL, AIR CLEANER	1	-	-----	EDF6,EDS1,EDS2,EDT1,ES3S,ES4S,VPKK,VPX4,VPXB,VPXE,VPXJ,VPXK,VPXX,VXEK VXKS
9	17367-413-690	FILTER, DRAIN TUBE	1	-	-----	EDF6,EDS1,EDS2,EDT1,ES3S,ES4S,VPKK,VPX4,VPXB,VPXE,VPXJ,VPXK,VPXX,VXEK VXKS
10	94050-05000	NUT, FLANGE, 5MM	6	-	-----	EDF6,EDS1,EDS2,EDT1,ES3S,ES4S,VPKK,VPX4,VPXB,VPXE,VPXJ,VPXK,VPXX,VXEK VXKS
11	94050-06000	NUT, FLANGE, 6MM	3	-	-----	EDF6,EDS1,EDS2,EDT1,ES3S,ES4S,VPKK,VPX4,VPXB,VPXE,VPXJ,VPXK,VPXX,VXEK VXKS
			-	2	-----	EDS1,EDS2,EDT1,ES2,VPKK,VPXB,VPXE,VPXK,VPXX,VXEK,VXKS

2

E-15-1

AIR CLEANER(2)

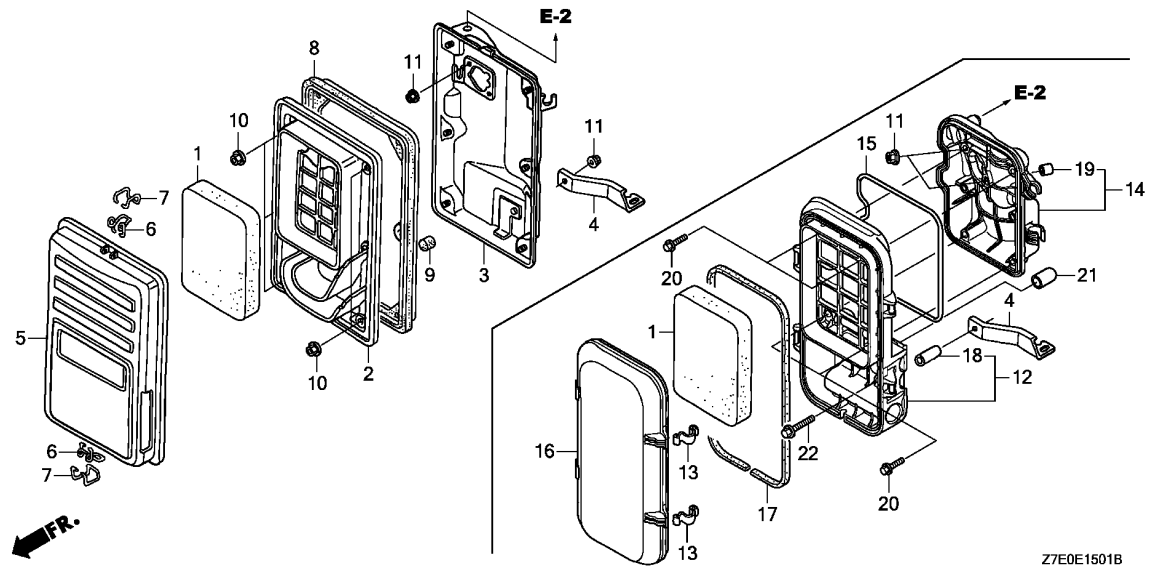

Ref. No.	Part No.	Description	Reqd. QTY		Serial No.	Parts catalogue code
			GX 390 H1	GX 390 H2		
12	17220-Z23-S30	CASE COMP., AIR CLEANER	-	1	-----	EDS1,EDS2,EDT1,ES2,VPKK,VPXB,VPXE,VPXK,VPXX,VXEK,VXKS
13	17223-Z23-000	SPRING, AIR CLEANER CASE LID	-	2	-----	EDS1,EDS2,EDT1,ES2,VPKK,VPXB,VPXE,VPXK,VPXX,VXEK,VXKS
14	17223-ZBH-000	BASE COMP., AIR CLEANER	-	1	-----	EDS1,EDS2,EDT1,ES2,VPKK,VPXB,VPXE,VPXK,VPXX,VXEK,VXKS
15	17229-Z23-H60	SEAL, AIR CLEANER CASE	-	1	-----	EDS1,EDS2,EDT1,ES2,VPKK,VPXB,VPXE,VPXK,VPXX,VXEK,VXKS
16	17231-ZBH-000	COVER, AIR CLEANER	-	1	-----	EDS1,EDS2,EDT1,ES2,VPKK,VPXB,VPXE,VPXK,VPXX,VXEK,VXKS
17	17233-Z23-H60	SEAL, AIR CLEANER COVER	-	1	-----	EDS1,EDS2,EDT1,ES2,VPKK,VPXB,VPXE,VPXK,VPXX,VXEK,VXKS
18	17238-ZE7-710	COLLAR, AIR CLEANER	-	1	-----	EDS1,EDS2,EDT1,ES2,VPKK,VPXB,VPXE,VPXK,VPXX,VXEK,VXKS
19	17238-ZG9-M00	COLLAR, AIR CLEANER	-	2	-----	EDS1,EDS2,EDT1,ES2,VPKK,VPXB,VPXE,VPXK,VPXX,VXEK,VXKS
20	90005-ZM3-000	BOLT, FLANGE, 5X18	-	4	-----	EDS1,EDS2,EDT1,ES2,VPKK,VPXB,VPXE,VPXK,VPXX,VXEK,VXKS
21	90802-Z6L-000	CAP, SEALING	-	1	-----	EDS1,EDS2,EDT1,ES2,VPKK,VPXB,VPXE,VPXK,VPXX,VXEK,VXKS
22	95701-06032-08	BOLT, FLANGE, 6X32	-	1	-----	EDS1,EDS2,EDT1,ES2,VPKK,VPXB,VPXE,VPXK,VPXX,VXEK,VXKS

E-15-2

AIR CLEANER(3)

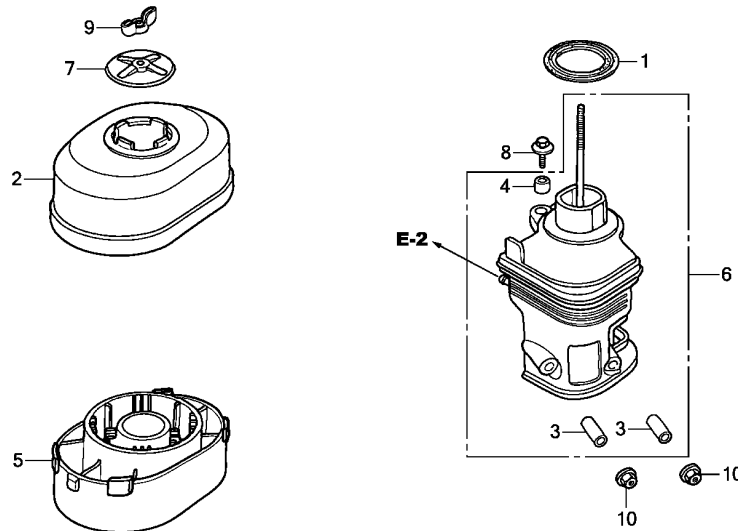

Ref. No.	L.O.N.	(Relative ref. Number) Description	F.R.T.
1	3121E1	PACKING, ELBOW	0.1
5	3121E5	PAN, AIR CLEANER OIL	0.1
6	3121B4	ELBOW, AIR CLEANER	0.1

Ref. No.	Part No.	Description	Reqd. QTY		Serial No.	Parts catalogue code
			GX 390 H1	GX 390 H2		
1	16271-ZE2-010	PACKING, ELBOW	1	-	-----	QBE1,QHB1,QP,SWE2,SWX2
2	17230-ZE3-811	COVER COMP., AIR CLEANER (OIL BATH)	1	-	-----	QBE1,QHB1,QP,SWE2,SWX2
3	17238-ZE2-310	COLLAR, AIR CLEANER	2	-	-----	QBE1,QHB1,QP,SWE2,SWX2
4	17239-ZE1-000	COLLAR B, AIR CLEANER	1	-	-----	QBE1,QHB1,QP,SWE2,SWX2
5	17402-ZE3-810	PAN, CLEANER OIL(OIL BATH) ..	1	-	-----	QBE1,QHB1,QP,SWE2,SWX2
6	17410-ZE3-010	ELBOW COMP., AIR CLEANER	1	-	-----	0415003 QBE1,QHB1,QP,SWE2,SWX2
	17410-ZE3-020	1	-	0415004	----- QBE1,QHB1,QP,SWE2,SWX2
7	17420-ZE3-810	CAP COMP., AIR CLEANER	1	-	-----	QBE1,QHB1,QP,SWE2,SWX2
8	90009-Z1C-000	BOLT-WASHER, 6X22	1	-	-----	QBE1,QHB1,QP,SWE2,SWX2
9	90325-044-000	NUT, TOOL BOX SETTING	1	-	-----	QBE1,QHB1,QP,SWE2,SWX2
10	94050-06000	NUT, FLANGE, 6MM	2	-	-----	QBE1,QHB1,QP,SWE2,SWX2

2

E-15-3

AIR CLEANER(4)

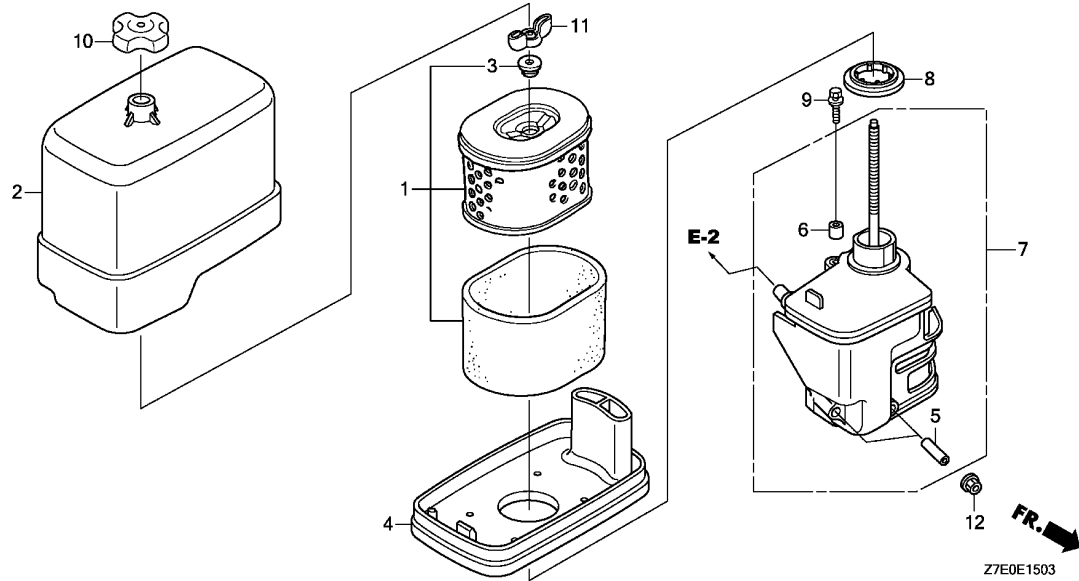

Ref. No.	L.O.N.	(Relative ref. Number) Description	F.R.T.
1	3121B8	ELEMENT, AIR CLEANERINCLUDES: Air cleaner element -inspection	0.1
4	3121D6	NOSE, SILENCER	0.1
7	3121B4	ELBOW, AIR CLEANER	0.1
8	3121R3	PACKING, AIR CLEANER CASE	0.1

Ref. No.	Part No.	Description	Reqd. QTY		Serial No.	Parts catalogue code
			GX 390 H1	GX 390 H2		
1	17210-Z7E-003	ELEMENT COMP., AIR CLEANER ..	-	1	-----	LH, LH1, PX, QH, QH1, QHE, QMH, QN, QX, QXE, QXHQ, SH, SH1, SHE, SM11, SWX2, SX, SX1 SXC, SXC1, VTE5, VX, VX1, VX1M, VXE, VXEM
2	17231-Z7E-930	COVER, AIR CLEANER	-	1	-----	LH, LH1, PX, QH, QH1, QHE, QMH, QN, QX, QXE, QXHQ, SH, SH1, SHE, SM11, SWX2, SX, SX1 SXC, SXC1, VTE5, VX, VX1, VX1M, VXE, VXEM
3	17232-Z1V-601	GROMMET, AIR CLEANER	-	1	-----	LH, LH1, PX, QH, QH1, QHE, QMH, QN, QX, QXE, QXHQ, SH, SH1, SHE, SM11, SWX2, SX, SX1 SXC, SXC1, VTE5, VX, VX1, VX1M, VXE, VXEM
4	17235-Z7E-930	NOSE, SILENCER	-	1	-----	LH, LH1, PX, QH, QH1, QHE, QMH, QN, QX, QXE, QXHQ, SH, SH1, SHE, SM11, SWX2, SX, SX1 SXC, SXC1, VTE5, VX, VX1, VX1M, VXE, VXEM
5	17238-Z7B-003	COLLAR, AIR CLEANER	-	2	-----	LH, LH1, PX, QH, QH1, QHE, QMH, QN, QX, QXE, QXHQ, SH, SH1, SHE, SM11, SWX2, SX, SX1 SXC, SXC1, VTE5, VX, VX1, VX1M, VXE, VXEM
6	17239-Z1T-601	COLLAR B, AIR CLEANER (ZHEJIANG HENGBO)	-	1	-----	LH, LH1, PX, QH, QH1, QHE, QMH, QN, QX, QXE, QXHQ, SH, SH1, SHE, SM11, SWX2, SX, SX1 SXC, SXC1, VTE5, VX, VX1, VX1M, VXE, VXEM
7	17410-Z7E-930	ELBOW COMP., AIR CLEANER	-	1	-----	LH, LH1, PX, QH, QH1, QHE, QMH, QN, QX, QXE, QXHQ, SH, SH1, SHE, SM11, SWX2, SX, SX1 SXC, SXC1, VTE5, VX, VX1, VX1M, VXE, VXEM
8	17417-Z5T-000	PACKING, AIR CLEANER CASE ...	-	1	-----	LH, LH1, PX, QH, QH1, QHE, QMH, QN, QX, QXE, QXHQ, SH, SH1, SHE, SM11, SWX2, SX, SX1 SXC, SXC1, VTE5, VX, VX1, VX1M, VXE, VXEM
9	90009-Z1C-000	BOLT-WASHER, 6X22	-	1	-----	LH, LH1, PX, QH, QH1, QHE, QMH, QN, QX, QXE, QXHQ, SH, SH1, SHE, SM11, SWX2, SX, SX1 SXC, SXC1, VTE5, VX, VX1, VX1M, VXE, VXEM
10	90202-Z2E-000	NUT, AIR CLEANER COVER	-	1	-----	LH, LH1, PX, QH, QH1, QHE, QMH, QN, QX, QXE, QXHQ, SH, SH1, SHE, SM11, SWX2, SX, SX1 SXC, SXC1, VTE5, VX, VX1, VX1M, VXE, VXEM
11	90325-044-000	NUT, TOOL BOX SETTING	-	1	-----	LH, LH1, PX, QH, QH1, QHE, QMH, QN, QX, QXE, QXHQ, SH, SH1, SHE, SM11, SWX2, SX, SX1 SXC, SXC1, VTE5, VX, VX1, VX1M, VXE, VXEM
12	94050-06000	NUT, FLANGE, 6MM	-	2	-----	LH, LH1, PX, QH, QH1, QHE, QMH, QN, QX, QXE, QXHQ, SH, SH1, SHE, SM11, SWX2, SX, SX1 SXC, SXC1, VTE5, VX, VX1, VX1M, VXE, VXEM



E-16

MUFFLER

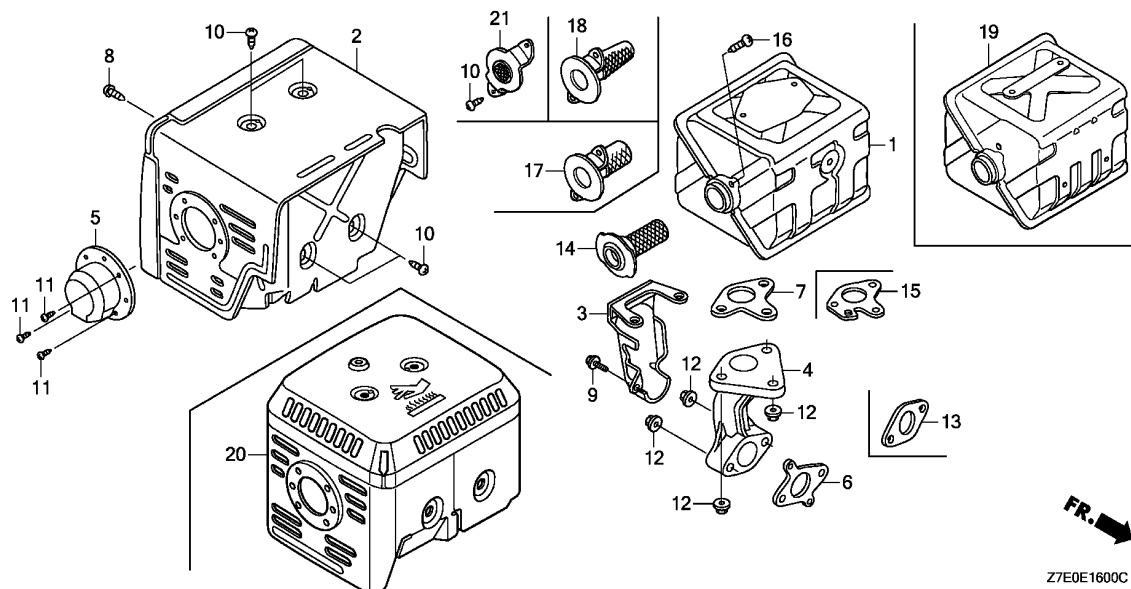

Ref. No.	L.O.N.	(Relative ref. Number) Description	F.R.T.
1	3131C5	(19) MUFFLER, EXHAUST	0.2
2	3131D6	(20) PROTECTOR, EXHAUST MUFFLER ...	0.2
4	3131C9	PIPE, EXHAUST	0.2
6	3131B5	(13) GASKET, EXHAUST PIPE	0.2
7	3131B4	(15) GASKET, EXHAUST MUFFLER	0.2
14	3131A1	(17,18) ARRESTER, SPARK	0.2
		.INCLUDES: Spark arrester check	
21	3131G5	FLANGE, EXHAUST BAFFLE	0.2

FR. →
Z7E0E1600C

Ref. No.	Part No.	Description	Reqd. QTY		Serial No.	Parts catalogue code
			GX 390 H1	GX 390 H2		
1	18310-ZE2-W62	MUFFLER COMP.(100dB)	1	-	-----	QA2,QHE,VPXJ,VPXK,VX1M,VXEM
	18310-ZE2-W61	1	-	0325786	LH,LH1,LH2,LHB5,LHP1,LXE9,PX,QBE1,QEBR,QH,QH1,QHB1,QHB3,QHB5,QHBR
						QHP1,QMH,QN,QP,QX,QXBR,QXE,QXEK,QXHQ,QXK,SH,SH1,SHE,SWE2,SWX2,SX,SX1
						SXC,SXC1,SXE,SXE1,VSP,VTE5,VX,VX1,VXE,VXK,VXU1
			1	-	0350668	SM11
			1	-	0374066	VPX4,VPXE
	18310-ZE2-W62	1	-	0325787	LH,LH1,LH2,LHB5,LHP1,LXE9,PX,QBE1,QEBR,QH,QH1,QHB1,QHB3,QHB5,QHBR
						QHP1,QMH,QN,QP,QX,QXBR,QXE,QXEK,QXHQ,QXK,SH,SH1,SHE,SWE2,SWX2,SX,SX1
						SXC,SXC1,SXE,SXE1,VSP,VTE5,VX,VX1,VXE,VXK,VXU1
			1	-	0350669	SM11
			1	-	0374067	VPX4,VPXE
2	18320-ZE2-W62	PROTECTOR COMP., MUFFLER	1	-	-----	LH1,LH2,LHB5,LHP1,LXE9,PX,QA2,QBE1,QEBR,QH1,QHB1,QHB3,QHB5,QHBR,QHE
						QHP1,QMH,QN,QP,QX,QXBR,QXE,QXEK,QXHQ,QXK,SH1,SWE2,SWX2,SX1,SXC1,SXE1
						VTE5,VX1,VX1M,VXE,VXEM,VXK,VXU1
	18320-ZE2-W61	1	-	0059856	LH,QA2,QH,SH,SHE,SM11,SX,SXC,SXE,VSP,VX
	18320-ZE2-W62	1	-	0059857	LH,QH,SH,SHE,SM11,SX,SXC,SXE,VSP,VX
3	18323-ZE3-W40	PROTECTOR, EX. PIPE	1	-	-----	QA2,SM11
	18323-Z5T-W41	1	-	-----	SM11
4	18330-ZE2-W00	PIPE, EX.	1	-	-----	LH,LH1,LH2,LHB5,LHP1,LXE9,PX,QA2,QBE1,QEBR,QH,QH1,QHB1,QHB3,QHB5,QHBR
						QHE,QHP1,QMH,QN,QP,QX,QXBR,QXE,QXEK,QXHQ,QXK,SH,SH1,SHE,SM11,SWE2
						SWX2,SX,SX1,SXC,SXC1,SXE,SXE1,VSP,VTE5,VX,VX1,VX1M,VXE,VXEM,VXK,VXU1
	18331-Z5T-000	-	1	-----	LH,LH1,PX,QH,QH1,QHE,QMH,QN,QX,QXE,QXHQ,SH,SH1,SHE,SM11,SWX2,SX,SX1
						SXC,SXC1,VTE5,VX,VX1,VX1M,VXE,VXEM
5	18331-ZE3-811	CAP, MUFFLER	1	1	-----	LHP1,QHP1,QMH,QN,QP,SM11,SWX2
6	18333-ZF6-W01	GASKET, EX. PIPE	1	1	-----	LH,LH1,LH2,LHB5,LHP1,LXE9,PX,QA2,QBE1,QEBR,QH,QH1,QHB1,QHB3,QHB5,QHBR
						QHE,QHP1,QMH,QN,QP,QX,QXBR,QXE,QXEK,QXHQ,QXK,SH,SH1,SHE,SM11,SWE2
						SWX2,SX,SX1,SXC,SXC1,SXE,SXE1,VSP,VTE5,VX,VX1,VX1M,VXE,VXEM,VXK,VXU1

2

E-16

MUFFLER

Ref. No.	Part No.	Description	Reqd. QTY		Serial No.	Parts catalogue code
			GX 390 H1	GX 390 H2		
7	18381-ZE2-801	GASKET, MUFFLER (NIPPON LEAKLESS)	1	1	-----	LH, LH1, LH2, LHB5, LHP1, LXE9, PX, QBE1, QEBR, QH, QH1, QHB1, QHB3, QHB5, QHBR, QHE, QHP1, QMH, QN, QP, QX, QXBR, QXE, QXEK, QXHQ, QXK, SH, SH1, SHE, SM11, SWE2, SWX2, SX, SX1, SXC, SXC1, SXE, SXE1, VSP, VTE5, VX, VX1, VX1M, VXE, VXEM, VVK, VXU1
	18381-Z1C-801	GASKET, MUFFLER (THAI LEAKLESS)	-	1	-----	LH, LH1, PX, QH, QH1, QHE, QMH, QN, QX, QXE, QXHQ, SH, SH1, SHE, SM11, SWX2, SX, SX1, SXC, SXC1, VTE5, VX, VX1, VX1M, VXE, VXEM
8	90006-ZE2-000	SCREW, TAPPING, 6X10	1	1	-----	LH, LH1, LH2, LHB5, LHP1, LXE9, PX, QA2, QBE1, QEBR, QH, QH1, QHB1, QHB3, QHB5, QHBR, QHE, QHP1, QMH, QN, QP, QX, QXBR, QXE, QXEK, QXHQ, QXK, SH, SH1, SHE, SM11, SWE2, SWX2, SX, SX1, SXC, SXC1, SXE, SXE1, VSP, VTE5, VX, VX1, VX1M, VXE, VXEM, VVK, VXU1, QA2, SM11
9	90013-883-000	BOLT, FLANGE, 6X12(CT200) ...	1	1	-----	
10	90050-ZE1-000	SCREW, TAPPING, 5X8	4	6	-----	LH, LH1, LH2, LHB5, LHP1, LXE9, PX, QA2, QBE1, QEBR, QH, QH1, QHB1, QHB3, QHB5, QHBR, QHE, QHP1, QMH, QN, QP, QX, QXBR, QXE, QXEK, QXHQ, QXK, SH, SH1, SHE, SM11, SWE2, SWX2, SX, SX1, SXC, SXC1, SXE, SXE1, VSP, VTE5, VX, VX1, VX1M, VXE, VXEM, VVK, VXU1
11	90055-ZE1-000	SCREW, TAPPING, 4X6	3	3	-----	LHP1, QHP1, QMH, QN, QP, SM11, SWX2
12	94050-08000	NUT, FLANGE, 8MM	5	-	-----	LH, LH1, LH2, LHB5, LHP1, LXE9, PX, QA2, QBE1, QEBR, QH, QH1, QHB1, QHB3, QHB5, QHBR, QHE, QHP1, QMH, QN, QP, QX, QXBR, QXE, QXEK, QXHQ, QXK, SH, SH1, SHE, SM11, SWE2, SWX2, SX, SX1, SXC, SXC1, SXE, SXE1, VPX4, VSP, VTE5, VX, VX1, VX1M, VXE, VXEM, VVK, VXU1
				2	-----	VPXB
				-	-----	LH, LH1, PX, QH, QH1, QHE, QMH, QN, QX, QXE, QXHQ, SH, SH1, SHE, SM11, SWX2, SX, SX1, SXC, SXC1, VTE5, VX, VX1, VX1M, VXE, VXEM
13	18333-ZE3-801	GASKET, EX. PIPE	1	-	-----	VPK, VPXE, VPXJ, VPXK, VPXX
	18333-ZE3-800	1	-	-----	VPX4
14	18355-ZE2-W00	ARRESTER, SPARK	(1)	-	-----	LXE9, QBE1, QHB1, VPXB, VXKS
			1	-	-----	QA2, VPX4, VPXE, VPXJ, VPXK
15	18381-ZE2-W10	GASKET, MUFFLER (ARRESTER) (NIPPON LEAKLESS)	(1)	-	-----	LXE9, QBE1, QHB1, VPXB, VXKS
	18381-Z8S-801	GASKET, MUFFLER (ARRESTER) (THAI LEAKLESS)	1	-	-----	QA2
	18381-ZE2-W10	GASKET, MUFFLER (ARRESTER) (NIPPON LEAKLESS)	1	-	-----	QA2, VPX4, VPXE, VPXJ, VPXK
16	90055-ZE1-000	SCREW, TAPPING, 4X6	(1)	-	-----	LXE9, QBE1, QHB1, VPXB, VXKS
	90050-ZE1-000	SCREW, TAPPING, 5X8	1	-	-----	QA2, VPX4, VPXE, VPXJ, VPXK
17	18350-Z5T-800	ARRESTER COMP., SPARK	(1)	-	-----	VPXB, VXKS
18	18355-ZE3-010	ARRESTER, SPARK	(1)	-	-----	VPXB, VXKS
19	18310-Z7E-930	MUFFLER COMP.	-	1	-----	LH, LH1, PX, QH, QH1, QHE, QMH, QN, QX, QXE, QXHQ, SH, SH1, SHE, SM11, SWX2, SX, SX1, SXC, SXC1, VTE5, VX, VX1, VX1M, VXE, VXEM
20	18320-Z5T-000	PROTECTOR COMP., MUFFLER	-	1	-----	LH, LH1, PX, QH, QH1, QHE, QMH, QN, QX, QXE, QXHQ, SH, SH1, SHE, SM11, SWX2, SX, SX1, SXC, SXC1, VTE5, VX, VX1, VX1M, VXE, VXEM
21	18336-ZE3-000	FLANGE COMP., BAFFLE	-	1	-----	LH, LH1, PX, QH, QH1, QHE, QMH, QN, QX, QXE, QXHQ, SH, SH1, SHE, SM11, SWX2, SX, SX1, SXC, SXC1, VTE5, VX, VX1, VX1M, VXE, VXEM

E-17

FUEL TANK

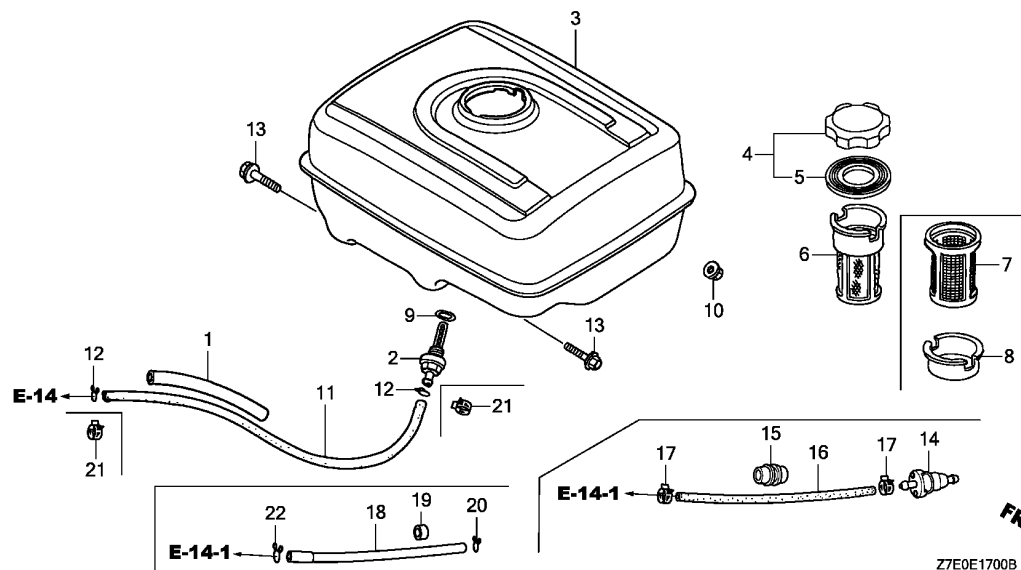

Ref. No.	L.O.N.	(Relative ref. Number) Description	F.R.T.
2		(9)	
3101H6		JOINT, FUEL STRAINER	0.2
3		TANK, FUEL	0.2
4		(5)	
3101M7		CAP, FUEL FILLER	0.1
6		(7,8)	
3101A6		FILTER, FUEL	0.1
11		TUBE, FUEL TANK	0.2
14		STRAINER, FUEL	0.2
16		(18)	
3101G0		TUBE, FUEL STRAINER	0.2

Ref. No.	Part No.	Description	Reqd. QTY		Serial No.	Parts catalogue code
			GX 390 H1	GX 390 H2		
1	16854-ZH8-000	RUBBER, SUPPORTER(107MM)	1	1	-----	LH, LH1, LH2, LHB5, LHP1, LXE9, PX, QA2, QBE1, QEBR, QH, QH1, QHB1, QHB3, QHB5, QHBR, QHE, QHP1, QMH, QN, QP, QX, QXBR, QXE, QXEK, QXHQ, QXK, SH, SH1, SHE, SM11, SWE2, SWX2, SX, SX1, SXC, SXC1, SXE, SXE1, VSP, VX, VX1, VXE, VXK, VXU1
2	16955-Z1T-010	JOINT, FUEL TANK	1	1	-----	LH, LH1, LH2, LHB5, LHP1, LXE9, PX, QA2, QBE1, QEBR, QH, QH1, QHB1, QHB3, QHB5, QHBR, QHE, QHP1, QMH, QN, QP, QX, QXBR, QXE, QXEK, QXHQ, QXK, SH, SH1, SHE, SM11, SWE2, SWX2, SX, SX1, SXC, SXC1, SXE, SXE1, VSP, VX, VX1, VXE, VXK, VXU1
3	17510-ZE3-801ZC	TANK COMP., FUEL *NH31*.....MCKINLEY WHITE	1	-	-----	LH, LH1, LH2, LHB5, LHP1, LXE9, PX, QA2, QBE1, QEBR, QH, QH1, QHB1, QHB3, QHB5, QHBR, QHE, QHP1, QMH, QN, QP, QX, QXBR, QXE, QXEK, QXHQ, QXK, SH, SH1, SHE, SM11, SWE2, SWX2, SX, SX1, SXC, SXC1, SXE, SXE1, VX, VX1, VXE, VXK, VXU1
	17510-ZE3-801ZA	*NH1*.....BLACK	1	-	-----	QXHQ, SX
	17510-ZE3-030ZA	*NH31*.....MCKINLEY WHITE	1	-	-----	VSP
	17510-ZE3-030ZB	*NH1*.....BLACK	1	-	-----	VSP
	17510-Z5T-000ZA	*NH1*.....BLACK	-	1	-----	LH, LH1, PX, QH, QH1, QHE, QMH, QN, QX, QXE, QXHQ, SH, SH1, SHE, SM11, SWX2, SX, SX1, SXC, SXC1, VX, VX1, VXE
	17510-Z5T-000ZB	*NH31*.....MCKINLEY WHITE	-	1	-----	LH, LH1, PX, QH, QH1, QHE, QMH, QN, QX, QXE, QXHQ, SH, SH1, SHE, SM11, SWX2, SX, SX1, SXC, SXC1, VX, VX1, VXE
4	17620-Z1T-800	CAP COMP., FUEL FILLER (CHROME PLATED) (TOYOSHA)	1	1	-----	LH, LH1, LH2, LHB5, LHP1, LXE9, PX, QA2, QBE1, QEBR, QH, QH1, QHB1, QHB3, QHB5, QHBR, QHE, QHP1, QMH, QN, QP, QX, QXBR, QXE, QXEK, QXHQ, QXK, SH, SH1, SHE, SM11, SWE2, SWX2, SX, SX1, SXC, SXC1, SXE, SXE1, VSP, VX, VX1, VXE, VXK, VXU1
5	17631-Z1T-800	PACKING, FUEL FILLER CAP (39X62X3) (TOYOSHA)	1	1	-----	LH, LH1, LH2, LHB5, LHP1, LXE9, PX, QA2, QBE1, QEBR, QH, QH1, QHB1, QHB3, QHB5, QHBR, QHE, QHP1, QMH, QN, QP, QX, QXBR, QXE, QXEK, QXHQ, QXK, SH, SH1, SHE, SM11, SWE2, SWX2, SX, SX1, SXC, SXC1, SXE, SXE1, VSP, VX, VX1, VXE, VXK, VXU1
6	17672-Z1T-000	FILTER, FUEL	1	1	-----	LHB5, QHB3, QHB5, QN, QP, SM11, SWX2, SXC1
7	17672-880-000	FILTER, FUEL	1	1	-----	SXC
8	17673-893-000	HOLDER, FUEL FILTER	1	1	-----	SXC

E-17

FUEL TANK

Ref. No.	Part No.	Description	Reqd. QTY		Serial No.	Parts catalogue code
			GX 390 H1	GX 390 H2		
9	91353-Z7E-003 91353-671-004	O-RING, 14MM O-RING, 14MM(NOK)	1 1	- -	- -	LH,QH,SH,SHE,SM11,SX,SXC,SXE,VSP,VX LH1,LH2,LHB5,LHP1,LXE9,PX,QA2,QBE1,QEBR,QH1,QHB1,QHB3,QHB5,QHBR,QHE QHP1,QMH,QN,QP,QX,QXBR,QXE,QXEK,QXHQ,QXK,SH1,SWE2,SWX2,SX1,SXC1,SXE1 VX1,VXE,VXK,VXU1
			-	1	-	LH,LH1,PX,QH,QH1,QHE,QMH,QN,QX,QXE,QXHQ,SH,SH1,SHE,SM11,SWX2,SX,SX1 SXC,SXC1,VX,VX1,VXE
10	94050-08000	NUT, FLANGE, 8MM	2	2	-	LH,LH1,LH2,LHB5,LHP1,LXE9,PX,QA2,QBE1,QEBR,QH,QH1,QHB1,QHB3,QHB5,QHBR QHE,QHP1,QMH,QN,QP,QX,QXBR,QXE,QXEK,QXHQ,QXK,SH,SH1,SHE,SM11,SWE2 SWX2,SX,SX1,SXC,SXC1,SXE,SXE1,VSP,VX,VX1,VXE,VXK,VXU1
11	95001-45235-40 (95001-45001-60M)	TUBE, FUEL, 4.5X235	1	1	-	LH,LH1,LH2,LHB5,LHP1,LXE9,PX,QA2,QEBR,QH,QH1,QHB3,QHB5,QHBR,QHE,QHP1 QMH,QN,QP,QX,QXBR,QXE,QXEK,QXHQ,QXK,SH,SH1,SHE,SM11,SWE2,SWX2,SX,SX1 SXC,SXC1,SXE,SXE1,VSP,VX,VX1,VXE,VXK,VXU1
	91424-Z5L-802	TUBE, FUEL, 4.5X235(FKM)	1	-	-	QBE1,QHB1
12	95002-02080	CLIP, TUBE(B8)	2	2	-	LH,LH1,LH2,LHB5,LHP1,LXE9,PX,QA2,QEBR,QH,QH1,QHB3,QHB5,QHBR,QHE,QHP1 QMH,QN,QP,QX,QXBR,QXE,QXEK,QXHQ,QXK,SH,SH1,SHE,SM11,SWE2,SWX2,SX,SX1 SXC,SXC1,SXE,SXE1,VSP,VX,VX1,VXE,VXK,VXU1
13	95701-08025-00	BOLT, FLANGE, 8X25	2	2	-	LH,LH1,LH2,LHB5,LHP1,LXE9,PX,QA2,QBE1,QEBR,QH,QH1,QHB1,QHB3,QHB5,QHBR QHE,QHP1,QMH,QN,QP,QX,QXBR,QXE,QXEK,QXHQ,QXK,SH,SH1,SHE,SM11,SWE2 SWX2,SX,SX1,SXC,SXC1,SXE,SXE1,VSP,VX,VX1,VXE,VXK,VXU1
14	16910-GB2-005	STRAINER COMP., FUEL	1	1	-	VPX4,VPXB,VPXE,VPXJ,VPXK
15	90854-ZB3-000	RUBBER, FUEL(9X15X20)	1	1	-	VPKK,VPX4,VPXB,VPXE,VPXJ,VPXK,VPXX
16	91424-Z4K-802 91424-Z4K-801 91424-Z4K-803	TUBE, FUEL, 4.5X180(FKM)	1 1 -	- - 1	- - -	VPKK,VPXB,VPXE,VPXJ,VPXK,VPXX VPX4 VPKK,VPXB,VPXE,VPXK,VPXX
17	95002-40800-08	CLAMP, TUBE(D8)	1	1	-	VPKK,VPXX
			2	2	-	VPX4,VPXB,VPXE,VPXJ,VPXK
18	16851-Z7E-800 16851-Z7E-810 95001-45165-40 (95001-45001-60M)	TUBE, FUEL, 4.5X150	1	1	-	ES2,VS4,VS6,VS64
		TUBE, FUEL, 4.5X250	1	1	-	VMQ3,VMT3,VXEK,VXKS
		TUBE, FUEL, 4.5X165	1	-	-	EDF6
19	90854-ZB2-000	RUBBER, FUEL(9X15X10)	1	1	-	EDF6,ES2,VMQ3,VMT3,VS4,VS6,VS64,VXEK,VXKS
20	95002-02080	CLIP, TUBE(B8)	1	1	-	EDF6,ES2,VMQ3,VMT3,VS4,VS6,VS64,VXEK,VXKS
21	95002-40800-08	CLAMP, TUBE(D8)	2	-	-	QBE1,QHB1
22	95002-50000 95002-02080	CLIP, TUBE(C9)	1	1	-	ES2,VMQ3,VMT3,VS4,VS6,VS64,VXEK,VXKS
		CLIP, TUBE(B8)	1	-	-	EDF6



E-19

FLYWHEEL

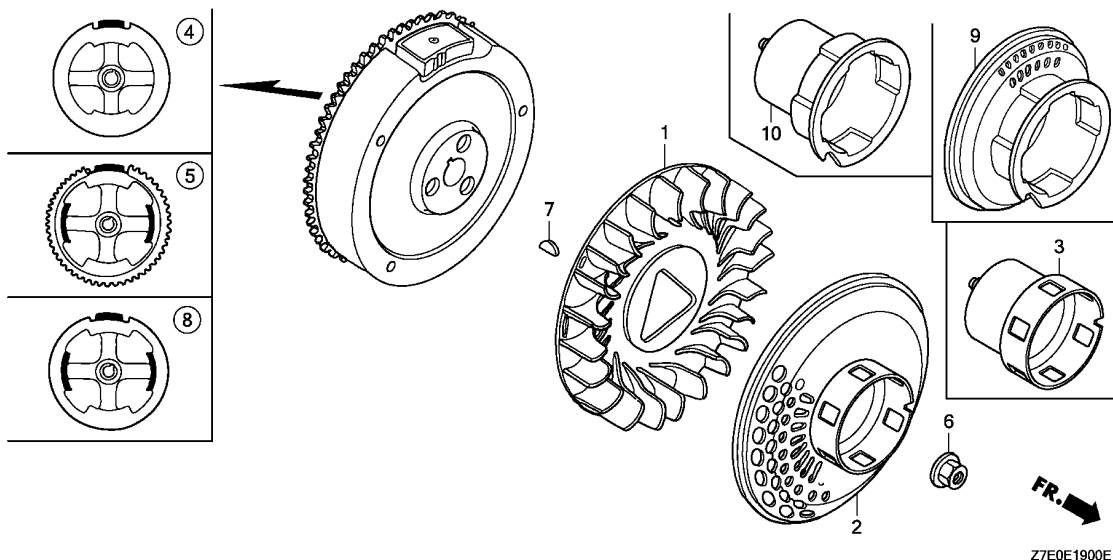

Ref. No.	L.O.N.	(Relative ref. Number) Description	F.R.T.
1	1141G7	FAN, ENGINE COOLING (3,9,10)	0.2
2	1121A9	PULLEY, RECOIL STARTER (5,8)	0.2
4	2161B5	FLYWHEEL	0.3

Ref. No.	Part No.	Description	Reqd. QTY		Serial No.	Parts catalogue code
			GX 390 H1	GX 390 H2		
1	19511-Z7E-000	FAN, COOLING	1	-	EDF6,EDS2,ES2,ES3S,ES4S,LH,LH1,LH2,LHB5,LHP1,LXE9,PX,QA2,QBE1,QEBR,QH,QH1,QHB1,QHB3,QHB5,QHBR,QHE,QHP1,QMH,QN,QP,QX,QXBR,QXE,QXEK,QXHQ,QXK,SH,SH1,SHE,SM11,SWE2,SWX2,SX,SX1,SXC,SXC1,SXE,SXE1,VMQ3,VMT3,VPKK,VPXB,VPXE,VPXJ,VPXK,VPXX,VS4,VS6,VSB4,VTE5,VX,VX1,VX1M,VXE,VXEK,VXEM,VXK,VXKS,VXU1	
	19511-ZE3-000		1	-	0007967	EDS1,EDT1,VPX4,VSP
	19511-Z7E-000		1	-	0007968	EDS1,EDT1,VPX4,VSP
2	28450-ZE3-W11	PULLEY COMP., STARTER (SCREEN GRID)	1	-	0001866	VSP
	28450-Z7E-000	PULLEY COMP., STARTER	1	-	0281238	LH,LH1,LH2,LHB5,LHP1,LXE9,PX,QBE1,QH,QH1,QHB1,QHB3,QHB5,QHP1,QMH,QP,QX,QXE,QXEK,QXHQ,QXK,SH,SH1,SHE,SWE2,SWX2,SX,SX1,SXC,SXC1,SXE,SXE1,VTE5,VX,VX1,VXE,VXK,VXU1
3	28451-ZE3-W01	PULLEY, STARTER	1	-	0001867	0281238 VSP
			1	-	0001866	VPX4
			1	-	0002756	EDS1,EDT1
	28451-Z7E-000		1	-	0281238	ES2,ES3S,ES4S,QA2,QN,SM11,VMQ3,VMT3,VPXB,VPXE,VS4,VS6,VSB4
			1	-	0001867	0281238 VPX4
			1	-	0002757	0281238 EDS1,EDT1
4	31110-Z7E-602	FLYWHEEL COMP.(YUXIN)	1	-	EDT1,ES2,ES3S,LH1,LH2,LHB5,PX,QA2,QH,QH1,QHB1,QHB3,QHB5,QHBR,QHP1,QMH,QN,QX,QXBR,QXHQ,QXK,SH,SH1,SM11,SX,SX1,SXC1,VPX4,VPXB,VS4,VS6,VS8,VSP,VX1,VXKS	
	31110-Z7E-801	FLYWHEEL COMP.	1	-	ES2,ES3S,LH1,LH2,LHB5,PX,QA2,QH,QH1,QHB1,QHB3,QHB5,QHBR,QHP1,QMH,QN,QX,QXBR,QXHQ,QXK,SH,SH1,SM11,SX,SX1,SXC1,VPXB,VS4,VS6,VS8,VX,VX1,VX1M,VXKS	
	31100-ZE3-701		1	-	0001866	EDT1,VPX4,VSP
	31110-Z7E-801		1	-	0139755	LH,SXC
			1	-	0001867	EDT1,VPX4,VSP
	31110-Z7E-602	FLYWHEEL COMP.(YUXIN)	1	-	0139756	LH,SXC

E-19

FLYWHEEL

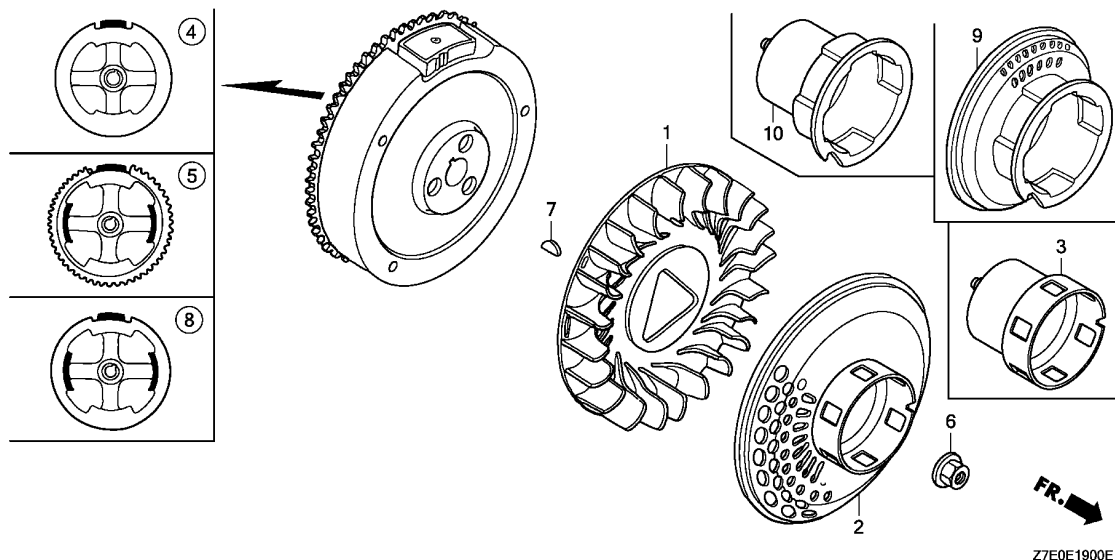

Ref. No.	Part No.	Description	Reqd. QTY		Serial No.	Parts catalogue code
			GX 390 H1	GX 390 H2		
(4)	31110-Z7E-931	FLYWHEEL COMP.	-	1	-----	EDT1,ES2,LH,LH1,PX,QH,QH1,QMH,QN,QX,QXH,Q,SH,SH1,SM11,SX,SX1,SXC,SXC1 VPXB,VX,VX1,VX1M,VXKS
5	31110-Z7E-612	FLYWHEEL COMP.(SEL-LAMP) (YUXIN)	1	-	-----	EDF6,EDS1,EDS2,ES4S,LXE9,QBE1,QEBR,QHE,QXE,QXEK,SWE2,SXE1,VMT3,VPKK VPXE,VPXJ,VPXK,VPXX,VS6,VTE5,VXE,VXEK,VXK,VXU1
	31110-Z7E-821	FLYWHEEL COMP.(SEL-LAMP)	1	-	-----	EDF6,EDS2,ES4S,LXE9,QBE1,QEBR,QXE,QXEK,SWE2,SXE1,VMT3,VPKK,VPXE,VPXJ VPXK,VPXX,VS6,VTE5,VXE,VXEK,VXEM,VXK,VXU1
	31100-ZE3-722	1	-	0002757	EDS1
	31110-Z7E-821	1	-	0132917	SHE,SXE
	31110-Z7E-612	FLYWHEEL COMP.(SEL-LAMP) (YUXIN)	1	-	0002758	EDS1
	31110-Z7E-951	FLYWHEEL COMP.(SEL-LAMP)	-	1	-----	EDS1,EDS2,QHE,QXE,SHE,VPKK,VPXE,VPXK,VPXX,VTE5,VXE,VXEK,VXEM
6	90201-ZE3-V00	NUT, SPECIAL, 16MM	1	1	-----	
7	90741-ZE2-000	KEY, SPECIAL WOODRUFF, 25X18	1	1	-----	
8	31110-Z7E-811	FLYWHEEL COMP.(LAMP)	1	-	-----	LHP1,QP,SWX2,VMQ3
	31110-Z7E-941	-	1	-----	SWX2
9	28450-Z7E-701	PULLEY COMP., STARTER	1	-	-----	QEBR,QHBR,QHE,QXBR
			1	-	0281239	LH,LH1,LH2,LHB5,LHP1,LXE9,PX,QBE1,QH,QH1,QHB1,QHB3,QHB5,QHP1,QMH,QP QX,QXE,QXEK,QXH,Q,QXK,SH,SH1,SHE,SWE2,SWX2,SX,SX1,SXC,SXC1,SXE,SXE1 VSP,VTE5,VX,VX1,VXE,VXK,VXU1
			-	1	-----	LH,LH1,PX,QH,QH1,QHE,QMH,QX,QXE,QXH,Q,SH,SH1,SHE,SWX2,SX,SX1,SXC,SXC1 VTE5,VX,VX1,VXE
10	28451-Z7E-701	PULLEY, STARTER	1	-	-----	EDF6,EDS2,VPKK,VPXJ,VPXK,VPXX,VX1M,VXEK,VXEM,VXKS
			1	-	0281239	EDS1,EDT1,ES2,ES3S,ES4S,QA2,QN,SM11,VMQ3,VMT3,VPX4,VPXB,VPXE,VS4,VS6 VSB4
			-	1	-----	EDS1,EDS2,EDT1,ES2,QN,SM11,VPKK,VPXB,VPXE,VPXK,VPXX,VX1M,VXEK,VXEM VXKS

E-20

IGNITION COIL

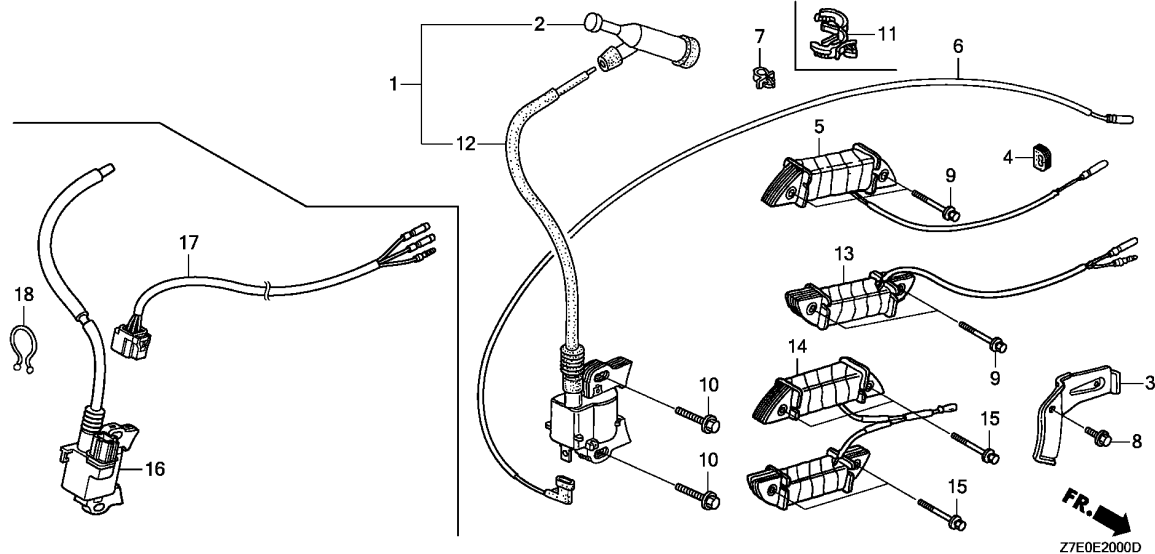

Ref. No.	L.O.N.	(Relative ref. Number) Description	F.R.T.
1		(12,16)	
6141A5		COIL, IGNITION(ONE)	0.2
2	6141B8	TERMINAL, HIGH TENSION	0.1
5	6131C3	COIL, CHARGE	0.4
6	6111B3	CORD, STOP SWITCH	0.3
13		(14)	
6141A6		COIL, LAMP	0.4
17	6111C0	HARNESS, ENGINE WIRE	0.4

Ref. No.	Part No.	Description	Reqd. QTY		Serial No.	Parts catalogue code
			GX 390 H1	GX 390 H2		
1	30500-Z7E-003	COIL ASSY., IGNITION	1	-	-----	EDS2,ES2,ES3S,ES4S,LH1,LH2,LHB5,LHP1,LXE9,PX,QA2,QBE1,QEBR,QH,QH1,QHB1,QHB3,QHB5,QHBR,QHE,QHP1,QMH,QN,QP,QX,QXBR,QXE,QXEK,QXHQ,QXK,SH,SH1,SHE,SM11,SWE2,SWX2,SX,SX1,SXC,SXC1,SXE,SXE1,VMQ3,VMT3,VPKK,VPXB,VPXE,VPXJ,VPXK,VPXX,VS4,VS6,VS4,VS6,VS4,VS6,VTE5,VX,VX1,VXE,VXEK,VXK,VXKS,VXU1
			1	-	0284342	LH
2	30700-Z1T-601	CAP ASSY., NOISE SUPPRESSOR (TOYO)	1	-	0001592	EDS1,EDT1,VPX4
	30700-Z1T-003	CAP ASSY., NOISE SUPPRESSOR (TEC)	1	-	-----	EDF6,VX1M,VXEM
	30700-Z1T-701	CAP ASSY., NOISE SUPPRESSOR (KOKUSAN)	1	-	-----	EDS2,ES2,ES3S,ES4S,LH1,LH2,LHB5,LHP1,LXE9,PX,QA2,QBE1,QEBR,QH,QH1,QHB1,QHB3,QHB5,QHBR,QHE,QHP1,QMH,QN,QP,QX,QXBR,QXE,QXEK,QXHQ,QXK,SH,SH1,SHE,SM11,SWE2,SWX2,SX,SX1,SXC,SXC1,SXE,SXE1,VMQ3,VMT3,VPKK,VPXB,VPXE,VPXJ,VPXK,VPXX,VS4,VS6,VS4,VS6,VTE5,VX,VX1,VXE,VXEK,VXK,VXKS,VXU1
	(30500-Z7E-701)		1	-	-----	EDS2,QHE,VPKK,VPXX,VXEK,VXKS
	30700-ZE1-013	CAP ASSY., NOISE SUPPRESSOR (NICHIIWA Y-EZ RTFM256)	1	-	0001591	EDS1,EDT1
	30700-Z1T-003	CAP ASSY., NOISE SUPPRESSOR (TEC)	1	-	0002904	VPX4
			1	-	0284342	LH
			1	-	0001592	EDS1,EDT1
			1	-	0002905	VPX4

2

E-20

IGNITION COIL

Ref. No.	Part No.	Description	Reqd. QTY		Serial No.	Parts catalogue code
			GX 390 H1	GX 390 H2		
(2)	30700-Z1T-701	CAP ASSY., NOISE SUPPRESSOR (KOKUSAN)	1	-	0284343	----- LH
	(30500-Z7E-701)		1	-	0650383	----- LH1, LH2, LHB5, LHP1, LXE9, PX, QA2, QBE1, QEBR, QH, QH1, QHB1, QHB3, QHB5, QHBR QHP1, QMH, QN, QP, QX, QXBR, QXE, QXEK, QXHQ, QXK, SH, SH1, SHE, SM11, SWE2, SWX2, SX SX1, SXC, SXC1, SXE, SXE1, VMQ3, VMT3, VPX4, VPXB, VPXE, VPXJ, VSP, VTE5, VX, VX1 VXE, VXX, VXU1
	//		1	-	0650519	----- EDS1, EDT1, ES2, ES3S, ES4S, VS4, VS6, VSB4
3	31511-Z7E-000	CLAMPER, CORD	1	-		----- EDF6, EDS2, ES4S, LHP1, LXE9, QBE1, QEBR, QHE, QP, QXE, QXEK, SHE, SWE2, SWX2, SXE SXE1, VMQ3, VMT3, VPKK, VPXE, VPXJ, VPKK, VPXX, VS6, VTE5, VXE, VXEK, VXEM, VXX VXU1
	31511-ZE3-000	1	-		----- EDS1
	31511-Z7E-000	-	1		----- EDS1, EDS2, QHE, QXE, SHE, SWX2, VPKK, VPXE, VPKK, VPXX, VTE5, VXE, VXEK, VXEM
4	31512-ZE2-000	GROMMET, CORD	1	1		
5	31630-ZE1-013	COIL ASSY., CHARGE(1A)	1	1		----- EDF6, EDS1, EDS2, ES4S, LXE9, QBE1, QEBR, QHE, QXE, QXEK, SHE, SWE2, SXE, SXE1 VMT3, VPKK, VPXE, VPXJ, VPKK, VPXX, VS6, VTE5, VXE, VXEK, VXEM, VXX, VXU1
6	36101-ZE3-800	CORD, STOP SWITCH(470MM)	1	-		----- EDF6, EDS1, EDS2, EDT1, ES2, ES3S, ES4S, VS4, VS6, VSB4
	32195-Z7E-711	1	-		----- EDS2
	(30500-Z7E-701)		1	-		----- LH1, LH2, LHB5, LHP1, LXE9, PX, QA2, QBE1, QEBR, QH, QH1, QHB1, QHB3, QHB5, QHBR QHE, QHP1, QMH, QN, QP, QX, QXBR, QXE, QXEK, QXHQ, QXK, SH, SH1, SHE, SM11, SWE2 SWX2, SX, SX1, SXC, SXC1, SXE, SXE1, VMQ3, VMT3, VPKK, VPX4, VPXB, VPXE, VPXJ, VPKK VPXX, VSP, VTE5, VX, VX1, VX1M, VXE, VXEK, VXEM, VXX, VXXS, VXU1
	36101-ZE2-701	CORD, STOP SWITCH(430MM)	1	-		
	32195-Z7E-701	1	-		----- QHE, VPKK, VPXX, VXEK, VXXS
	(30500-Z7E-701)		1	-	0284342	----- LH
	36101-ZE2-701	1	-	0284343	----- LH
	32195-Z7E-701	1	-	0650383	----- LH
	36101-ZE2-701	1	-		
	32195-Z7E-701	1	-	0650383	----- LH1, LH2, LHB5, LHP1, LXE9, PX, QA2, QBE1, QEBR, QH, QH1, QHB1, QHB3, QHB5, QHBR QHP1, QMH, QN, QP, QX, QXBR, QXE, QXEK, QXHQ, QXK, SH, SH1, SHE, SM11, SWE2, SWX2, SX SX1, SXC, SXC1, SXE, SXE1, VMQ3, VMT3, VPX4, VPXB, VPXE, VPXJ, VSP, VTE5, VX, VX1 VXE, VXX, VXU1
	32195-Z7E-711	CORD, STOP SWITCH(470MM)	1	-	0650519	----- EDS1, EDT1, ES2, ES3S, ES4S, VS4, VS6, VSB4
	(30500-Z7E-701)		1	-		----- ES2, LH, LH1, QEBR, QH, QH1, QHB1, QHBR, QHE, QHP1, QMH, QN, QXE, SH, SH1, SHE, SM11 SWE2, SXE, VTE5, VXE, VXEM
7	36103-V42-000	HOLDER, STOP SWITCH CORD	1	-		----- ES3S, LH2, LHB5, LHP1, LXE9, QBE1, QHB3, QHB5, QP, QXEK, SXE1, VMQ3, VMT3, VS4 VSB4, VXX, VXU1
	36103-ZE1-000	1	-		----- ES2, QHE, QXE, SHE, VTE5, VXE, VXEM
	36103-V42-000	-	1		
8	90013-883-000	BOLT, FLANGE, 6X12(CT200) ...	1	1		----- EDF6, EDS1, EDS2, ES4S, LHP1, LXE9, QBE1, QEBR, QHE, QP, QXE, QXEK, SHE, SWE2, SWX2 SXE, SXE1, VMQ3, VMT3, VPKK, VPXE, VPXJ, VPKK, VPXX, VS6, VTE5, VXE, VXEK, VXEM VXX, VXU1
9	90014-ZE6-000	BOLT, FLANGE, 6X35(CT200) ...	2	2		----- EDF6, EDS1, EDS2, ES4S, LXE9, QBE1, QEBR, QHE, QXE, QXEK, SHE, SWE2, SXE, SXE1 VMT3, VPKK, VPXE, VPXJ, VPKK, VPXX, VS6, VTE5, VXE, VXEK, VXEM, VXX, VXU1
	90012-888-000	BOLT, FLANGE, 6X40(CT200) ...	2	-		----- LHP1
	90017-883-000	BOLT, FLANGE, 6X32(CT200) ...	2	-		----- VMQ3, VMT3
10	90015-883-000	BOLT, FLANGE, 6X28(CT200) ...	2	2		
11	90684-Z7E-000	CLIP, HARNESS	1	-		----- PX, QA2, QX, QXBR, QXHQ, QXK, SWX2, SX, SX1, SXC, SXC1, VPXB, VX, VX1, VX1M, VXXS
	90684-ZA0-601	1	-	0011400	----- EDT1, VPX4, VSP
	90684-Z7E-000	1	-	0011401	----- EDT1, VPX4, VSP
			-	1		----- EDT1, LH, LH1, PX, QH, QH1, QX, QXHQ, SH, SH1, SWX2, SX, SX1, SXC, SXC1, VPXB, VX, VX1 VX1M, VXXS
12	30500-Z7E-601	COIL ASSY., IGNITION	1	-		----- EDF6, VX1M, VXEM
	30500-Z7E-701	1	-		----- EDS2, QHE, VPKK, VPXX, VXEK, VXXS
	30500-ZF6-W03	1	-	0001591	----- EDS1, EDT1, VPX4



E-20

IGNITION COIL

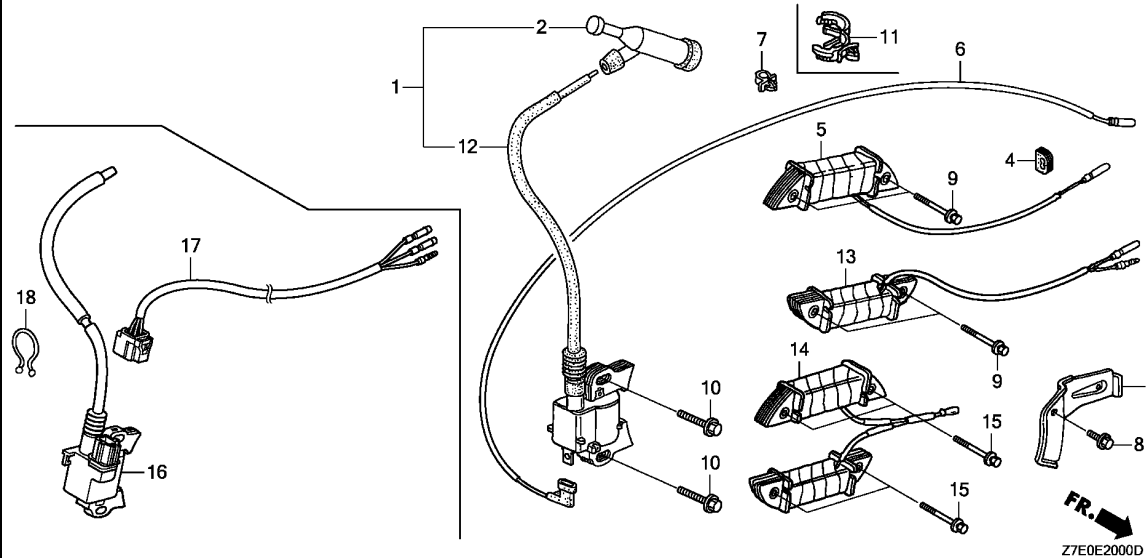

Ref. No.	Part No.	Description	Reqd. QTY		Serial No.	Parts catalogue code
			GX 390 H1	GX 390 H2		
12)	30500-Z7E-701	COIL ASSY., IGNITION	1	-	0284343	LH
			1	-	0650383	LH1, LH2, LHB5, LHP1, LXE9, PX, QA2, QBE1, QEBR, QH, QH1, QHB1, QHB3, QHB5, QHBR, QHP1, QMH, QN, QP, QX, QXBR, QXE, QXEK, QXHQ, QXK, SH, SH1, SHE, SM11, SWE2, SWX2, SX, SX1, SXC, SXC1, SXE, SXE1, VMQ3, VMT3, VPX4, VPXB, VPXE, VPXJ, VSP, VTE5, VX, VX1, VXE, VXX, VXU1
			1	-	0650519	EDS1, EDT1, ES2, ES3S, ES4S, VS4, VS6, VSB4
13	31510-ZE1-811	COIL ASSY., LAMP(12V/25W)	1	-		LHP1
	31510-ZE1-003	COIL ASSY., LAMP(12V/15W)	1	-		VMQ3, VMT3
14	31510-ZE2-811	COIL ASSY., LAMP(12V/50W)	1	1		QP, SWX2
15	90012-888-000	BOLT, FLANGE, 6X40(CT200)	4	4		QP, SWX2
16	30500-Z7E-931	COIL ASSY., IGNITION	-	1		
17	32110-Z5K-810	HARNESS ASSY., ENGINE WIRE	-	1		EDS1, EDS2, QXE, VPKK, VPXE, VPXK, VPXX, VTE5, VXE, VXEK, VXEM
	(SEL)		-	1		EDT1, ES2, PX, QX, QXHQ, SH, SWX2, SX, SX1, SXC, SXC1, VPXB, VX, VX1, VX1M, VXKS
	32110-Z5K-800	HARNESS ASSY., ENGINE WIRE	-	1		LH, LH1, QH, QH1, QMH, QN, SH1, SM11
	32110-Z5K-820	HARNESS ASSY., ENGINE WIRE	-	1		QHE, SHE
	(SEL)		-	1		EDS1, EDS2, QHE, QXE, SHE, VPKK, VPXE, VPXK, VPXX, VTE5, VXE, VXEK, VXEM
18	90630-751-000	CLIP, PURSE LOCK	-	1		

E-21

STARTER MOTOR(1)

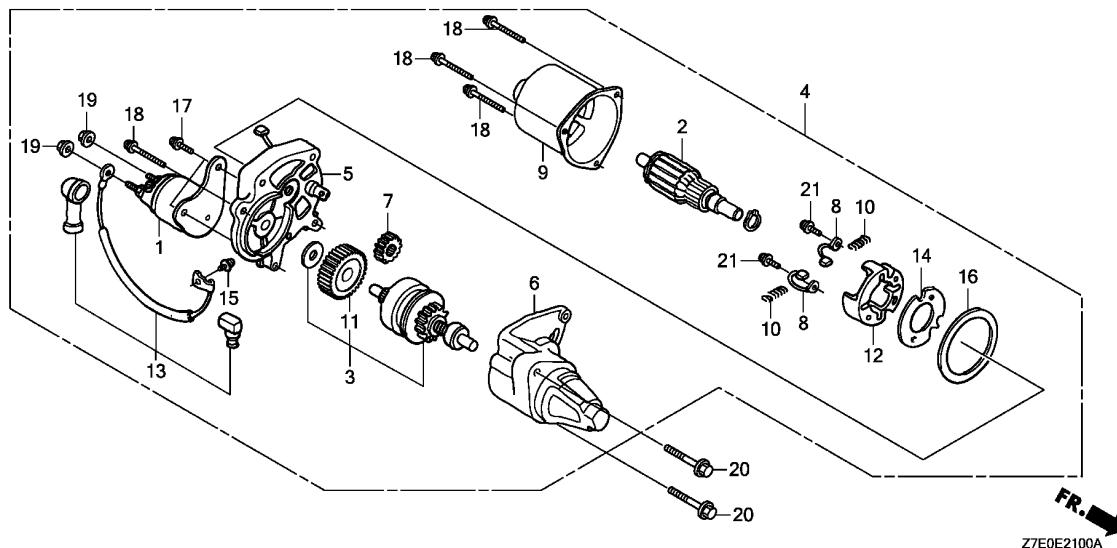

Ref. No.	L.O.N.	(Relative ref. Number) Description	F.R.T.
1	6121E5	CONTACTOR, STARTER	0.2
2	6121A0	ARMATURE, STARTER	0.4
3	6121B0	CLUTCH, OVERRUNNING	0.4
4	6121D5	MOTOR, STARTER	0.2
5	6121C3	BRACKET, STARTER :CENTER	0.4
6	6121D2	BRACKET, STARTER :FRONT	0.3
8	6121A9	BRUSH, STARTER	0.4

Ref. No.	Part No.	Description	Reqd. QTY		Serial No.	Parts catalogue code
			GX 390 H1	GX 390 H2		
1	31204-ZA0-003	CONTACTOR ASSY.	1	1	-----	ES4S,LXE9,QBE1,QEBR,QXE,QXEK,SWE2,SXE1,VMT3,VS6,VTE5,VXE,VXEM,VXK VXU1
2	31206-ZE3-003	ARMATURE COMP.	1	-	0287079	EDS1,SHE,SXE,VPXE
3	31207-ZE3-003	CLUTCH COMP., OVERRUNNING ...	1	-	0287079	ES4S,LXE9,QBE1,QEBR,QXE,QXEK,SWE2,SXE1,VMT3,VS6,VTE5,VXE,VXEM,VXK VXU1
	31208-ZE3-003	1	-	0287079	EDS1,SHE,SXE,VPXE
4	31210-ZE3-023	MOTOR UNIT, STARTER	1	-	-----	QXE,VTE5,VXE,VXEM
	31210-ZE3-033	1	-	0287079	ES4S,LXE9,QBE1,QEBR,QXE,QXEK,SWE2,SXE1,VMT3,VS6,VTE5,VXE,VXEM,VXK VXU1
5	31211-ZE2-003	BRACKET, CENTER	1	1	-----	ES4S,LXE9,QBE1,QEBR,QXE,QXEK,SWE2,SXE1,VMT3,VS6,VTE5,VXE,VXEM,VXK VXU1
		1	-	0287079	EDS1,SHE,SXE,VPXE
6	31212-ZE3-003	BRACKET, FR.	1	1	-----	ES4S,LXE9,QBE1,QEBR,QXE,QXEK,SWE2,SXE1,VMT3,VS6,VTE5,VXE,VXEM,VXK VXU1
7	31213-ZE2-003	GEAR, DRIVE PINION	1	-	0287079	EDS1,SHE,SXE,VPXE
		1	1	-----	ES4S,LXE9,QBE1,QEBR,QXE,QXEK,SWE2,SXE1,VMT3,VS6,VTE5,VXE,VXEM,VXK VXU1
8	31215-ZE2-003	BRUSH	1	-	0287079	EDS1,SHE,SXE,VPXE
		2	2	-----	ES4S,LXE9,QBE1,QEBR,QXE,QXEK,SWE2,SXE1,VMT3,VS6,VTE5,VXE,VXEM,VXK VXU1
		2	-	0287079	EDS1,SHE,SXE,VPXE



E-21

STARTER MOTOR(1)

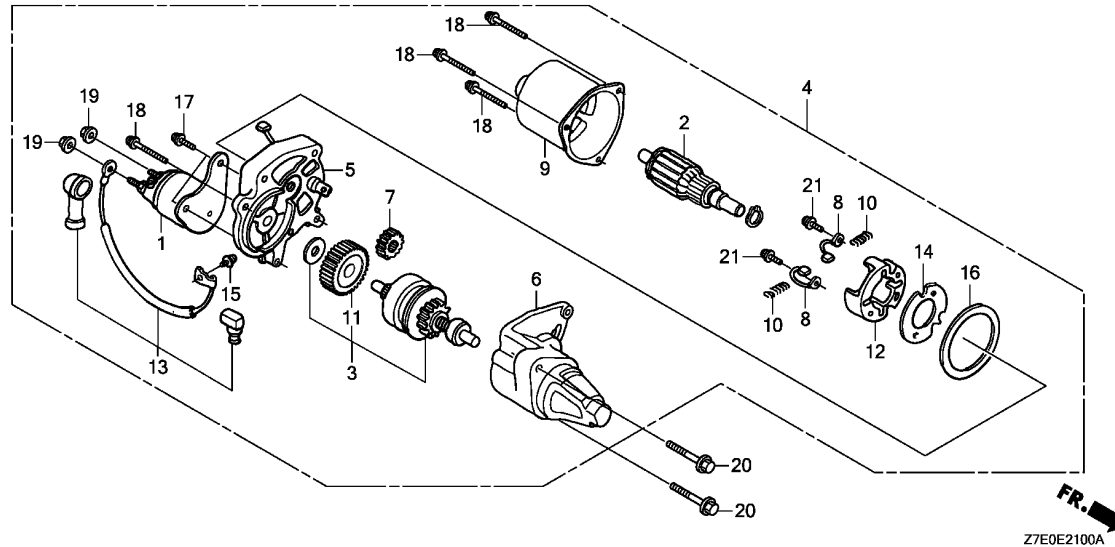

Ref. No.	Part No.	Description	Reqd. QTY		Serial No.	Parts catalogue code
			GX 390 H1	GX 390 H2		
9	31218-ZE3-003	YOKE COMP.	1	1	-----	ES4S,LXE9,QBE1,QEBR,QXE,QXEK,SWE2,SXE1,VMT3,VS6,VTE5,VXE,VXEM,VXK VXU1
10	31219-ZE2-003	SPRING, BRUSH RETURN	1	-	0287079	EDS1,SHE,SXE,VPXE
			4	4	-----	ES4S,LXE9,QBE1,QEBR,QXE,QXEK,SWE2,SXE1,VMT3,VS6,VTE5,VXE,VXEM,VXK VXU1
			4	-	0287079	EDS1,SHE,SXE,VPXE
11	31222-ZE3-791	GEAR, REDUCTION	1	1	-----	ES4S,LXE9,QBE1,QEBR,QXE,QXEK,SWE2,SXE1,VMT3,VS6,VTE5,VXE,VXEM,VXK VXU1
			1	-	0287079	EDS1,SHE,SXE,VPXE
12	31231-ZE2-003	HOLDER, BRUSH	1	1	-----	ES4S,LXE9,QBE1,QEBR,QXE,QXEK,SWE2,SXE1,VMT3,VS6,VTE5,VXE,VXEM,VXK VXU1
			1	-	0287079	EDS1,SHE,SXE,VPXE
13	31232-ZE3-003	WIRE, WATER COVER	1	1	-----	ES4S,LXE9,QBE1,QEBR,QXE,QXEK,SWE2,SXE1,VMT3,VS6,VTE5,VXE,VXEM,VXK VXU1
			1	-	0287079	EDS1,SHE,SXE,VPXE
14	31233-ZE2-003	INSULATOR	1	1	-----	ES4S,LXE9,QBE1,QEBR,QXE,QXEK,SWE2,SXE1,VMT3,VS6,VTE5,VXE,VXEM,VXK VXU1
			1	-	0287079	EDS1,SHE,SXE,VPXE
15	90110-ZE2-003	SCREW-WASHER, 4X6	1	1	-----	ES4S,LXE9,QBE1,QEBR,QXE,QXEK,SWE2,SXE1,VMT3,VS6,VTE5,VXE,VXEM,VXK VXU1
			1	-	0287079	EDS1,SHE,SXE,VPXE
16	91601-ZE2-003	PACKING	1	1	-----	ES4S,LXE9,QBE1,QEBR,QXE,QXEK,SWE2,SXE1,VMT3,VS6,VTE5,VXE,VXEM,VXK VXU1
			1	-	0287079	EDS1,SHE,SXE,VPXE
17	90007-ZE2-003	BOLT-WASHER, 5X14	2	2	-----	ES4S,LXE9,QBE1,QEBR,QXE,QXEK,SWE2,SXE1,VMT3,VS6,VTE5,VXE,VXEM,VXK VXU1
			2	-	0287079	EDS1,SHE,SXE,VPXE

E-21

STARTER MOTOR(1)

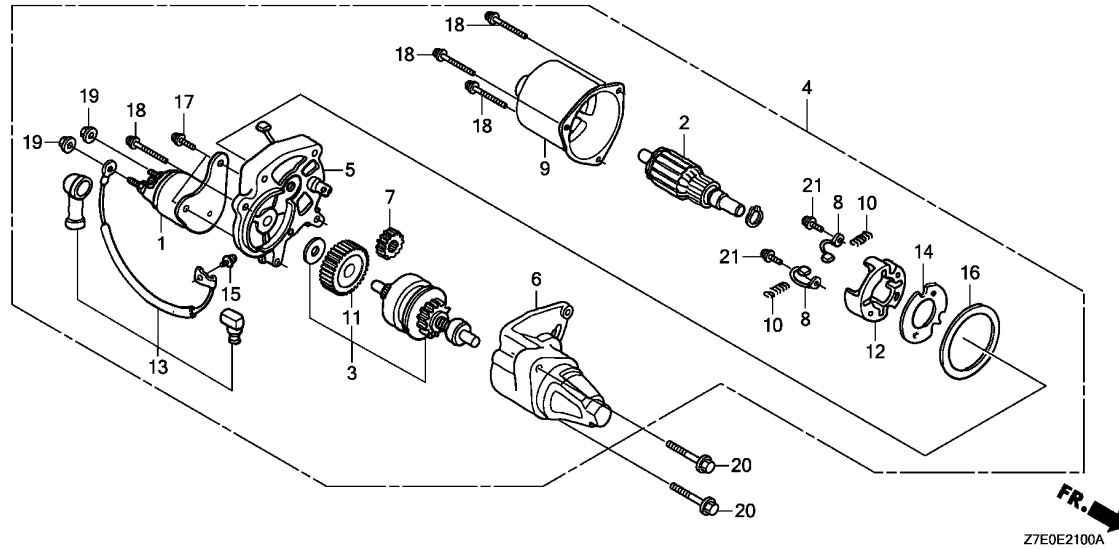

Ref. No.	Part No.	Description	Reqd. QTY		Serial No.	Parts catalogue code
			GX 390 H1	GX 390 H2		
18	93892-05032-18	SCREW-WASHER, 5X32	4	4	-----	ES4S,LXE9,QBE1,QEBR,QXE,QXEK,SWE2,SXE1,VMT3,VS6,VTE5,VXE,VXEM,VXK VXU1
19	94070-06080	NUT-WASHER, 6MM	4	-	0287079	EDS1,SHE,SXE,VPXE
20	95701-08035-08	BOLT, FLANGE, 8X35	2	-	0287079	ES4S,LXE9,QBE1,QEBR,QXE,QXEK,SWE2,SXE1,VMT3,VS6,VTE5,VXE,VXEM,VXK VXU1
			2	-	0287079	EDS1,SHE,SXE,VPXE
21	31219-ZE3-003	SCREW-WASHER, 4X14	2	2	-----	ES4S,LXE9,QBE1,QEBR,QXE,QXEK,SWE2,SXE1,VMT3,VS6,VTE5,VXE,VXEM,VXK VXU1
			2	-	0287079	EDS1,SHE,SXE,VPXE



E-21-1

STARTER MOTOR(2)

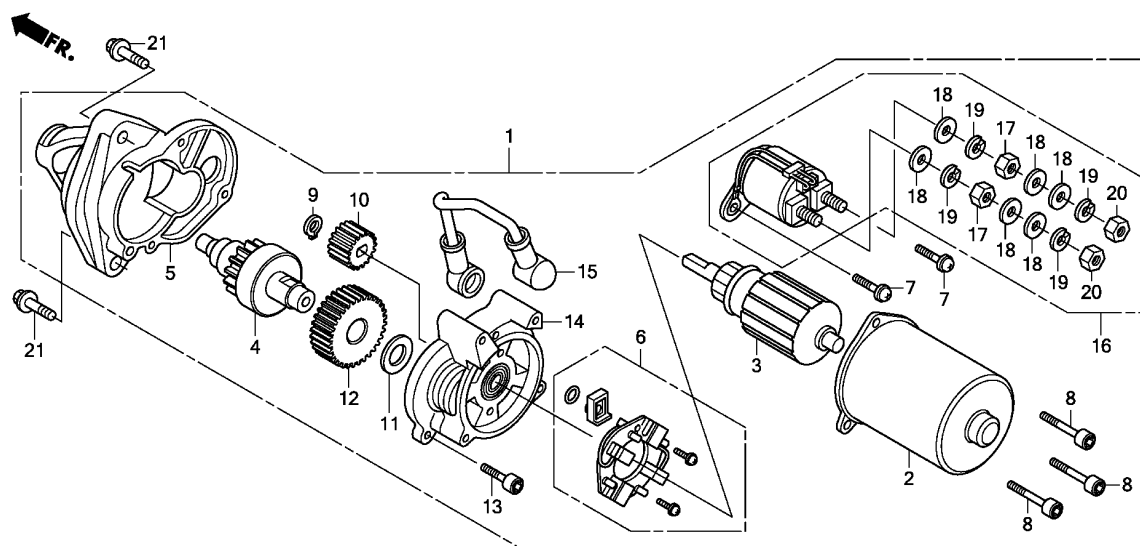

Z7E0E2101

Ref. No.	L.O.N.	(Relative ref. Number) Description	F.R.T.
1	6121D5	MOTOR, STARTER	0.2
3	6121A0	ARMATURE, STARTER	0.4
4	6121B0	CLUTCH, OVERRUNNING	0.4
5	6121D2	BRACKET, STARTER :FRONT	0.3
6	6121A9	BRUSH, STARTER	0.4
10	6121E8	GEAR, STARTER DRIVE PINION ...	0.4
12	6121B5	GEAR, STARTER REDUCTION	0.4
14	6121C3	BRACKET, STARTER :CENTER	0.4
15	610115	CABLE, BATTERY STARTER	0.2
16	6121C9	SWITCH, STARTER MAGNETIC	0.3

Ref. No.	Part No.	Description	Reqd. QTY		Serial No.	Parts catalogue code	
			GX 390 H1	GX 390 H2			
1	31200-Z7E-701	MOTOR ASSY., STARTER	1	-	-----	EDF6,EDS2,QHE,VPKK,VPXJ,VPXK,VPXX,VXEK	
	31200-Z7E-931	-	1	0287080	-----	EDS1,SHE,SXE,VPXE
2	31211-Z7E-701	HOUSING ASSY.	1	-	-----	EDF6,EDS2,QHE,VPKK,VPXJ,VPXK,VPXX,VXEK	
			1	-	0287080	-----	EDS1,SHE,SXE,VPXE
			-	1	-----	EDS1,EDS2,QHE,SHE,VPKK,VPXE,VPXK,VPXX,VXEK	
3	31212-Z7E-701	ARMATURE ASSY.	1	-	-----	EDF6,EDS2,QHE,VPKK,VPXJ,VPXK,VPXX,VXEK	
			1	-	0287080	-----	EDS1,SHE,SXE,VPXE
4	31213-Z7E-701	GEAR ASSY., DRIVE	1	-	-----	EDF6,EDS2,QHE,VPKK,VPXJ,VPXK,VPXX,VXEK	
			1	-	0287080	-----	EDS1,SHE,SXE,VPXE
			-	1	-----	EDS1,EDS2,QHE,SHE,VPKK,VPXE,VPXK,VPXX,VXEK	
5	31214-Z7E-701	CONE ASSY., NOSE	1	-	-----	EDF6,EDS2,QHE,VPKK,VPXJ,VPXK,VPXX,VXEK	
			1	-	0287080	-----	EDS1,SHE,SXE,VPXE
			-	1	-----	EDS1,EDS2,QHE,SHE,VPKK,VPXE,VPXK,VPXX,VXEK	
6	31215-Z7E-701	BOARD ASSY., BRUSH	1	-	-----	EDF6,EDS2,QHE,VPKK,VPXJ,VPXK,VPXX,VXEK	
			1	-	0287080	-----	EDS1,SHE,SXE,VPXE
			-	1	-----	EDS1,EDS2,QHE,SHE,VPKK,VPXE,VPXK,VPXX,VXEK	
7	31217-Z7E-701	SCREW A	2	-	-----	EDF6,EDS2,QHE,VPKK,VPXJ,VPXK,VPXX,VXEK	
			2	-	0287080	-----	EDS1,SHE,SXE,VPXE
			-	2	-----	EDS1,EDS2,QHE,SHE,VPKK,VPXE,VPXK,VPXX,VXEK	
8	31218-Z7E-701	SCREW B	3	-	-----	EDF6,EDS2,QHE,VPKK,VPXJ,VPXK,VPXX,VXEK	
			3	-	0287080	-----	EDS1,SHE,SXE,VPXE
			-	3	-----	EDS1,EDS2,QHE,SHE,VPKK,VPXE,VPXK,VPXX,VXEK	
9	31222-Z7E-701	RING, RETAINER	1	-	-----	EDF6,EDS2,QHE,VPKK,VPXJ,VPXK,VPXX,VXEK	
			1	-	0287080	-----	EDS1,SHE,SXE,VPXE
			-	1	-----	EDS1,EDS2,QHE,SHE,VPKK,VPXE,VPXK,VPXX,VXEK	

E-21-1

STARTER MOTOR(2)

Ref. No.	Part No.	Description	Reqd. QTY		Serial No.	Parts catalogue code
			GX 390 H1	GX 390 H2		
10	31223-Z7E-701	GEAR A	1	-	-----	EDF6,EDS2,QHE,VPKK,VPXJ,VPXK,VPXX,VXEK
			1	-	0287080	EDS1,SHE,SXE,VPXE
			-	1	-----	EDS1,EDS2,QHE,SHE,VPKK,VPXE,VPXK,VPXX,VXEK
11	31224-Z7E-701	WASHER	1	-	-----	EDF6,EDS2,QHE,VPKK,VPXJ,VPXK,VPXX,VXEK
			1	-	0287080	EDS1,SHE,SXE,VPXE
			-	1	-----	EDS1,EDS2,QHE,SHE,VPKK,VPXE,VPXK,VPXX,VXEK
12	31225-Z7E-701	GEAR B	1	-	-----	EDF6,EDS2,QHE,VPKK,VPXJ,VPXK,VPXX,VXEK
			1	-	0287080	EDS1,SHE,SXE,VPXE
			-	1	-----	EDS1,EDS2,QHE,SHE,VPKK,VPXE,VPXK,VPXX,VXEK
13	31226-Z7E-701	SCREW C	1	-	-----	EDF6,EDS2,QHE,VPKK,VPXJ,VPXK,VPXX,VXEK
			1	-	0287080	EDS1,SHE,SXE,VPXE
			-	1	-----	EDS1,EDS2,QHE,SHE,VPKK,VPXE,VPXK,VPXX,VXEK
14	31230-Z7E-701	BRACKET ASSY.	1	-	-----	EDF6,EDS2,QHE,VPKK,VPXJ,VPXK,VPXX,VXEK
			1	-	0287080	EDS1,SHE,SXE,VPXE
			-	1	-----	EDS1,EDS2,QHE,SHE,VPKK,VPXE,VPXK,VPXX,VXEK
15	32410-Z7E-701	CABLE ASSY., STARTER	1	-	-----	EDF6,EDS2,QHE,VPKK,VPXJ,VPXK,VPXX,VXEK
			1	-	0287080	EDS1,SHE,SXE,VPXE
			-	1	-----	EDS1,EDS2,QHE,SHE,VPKK,VPXE,VPXK,VPXX,VXEK
16	35850-Z7E-701	SWITCH ASSY., STARTER MAGNETIC	1	-	-----	EDF6,EDS2,QHE,VPKK,VPXJ,VPXK,VPXX,VXEK
			1	-	0287080	EDS1,SHE,SXE,VPXE
			-	1	-----	EDS1,EDS2,QHE,SHE,VPKK,VPXE,VPXK,VPXX,VXEK
17	35851-Z7E-701	NUT, HEX., 6MM	2	-	-----	EDF6,EDS2,QHE,VPKK,VPXJ,VPXK,VPXX,VXEK
			2	-	0287080	EDS1,SHE,SXE,VPXE
			-	2	-----	EDS1,EDS2,QHE,SHE,VPKK,VPXE,VPXK,VPXX,VXEK
18	35852-Z7E-701	WASHER	6	-	-----	EDF6,EDS2,QHE,VPKK,VPXJ,VPXK,VPXX,VXEK
			6	-	0287080	EDS1,SHE,SXE,VPXE
			-	6	-----	EDS1,EDS2,QHE,SHE,VPKK,VPXE,VPXK,VPXX,VXEK
19	35853-Z7E-701	WASHER, SPRING, 6MM	4	-	-----	EDF6,EDS2,QHE,VPKK,VPXJ,VPXK,VPXX,VXEK
			4	-	0287080	EDS1,SHE,SXE,VPXE
			-	4	-----	EDS1,EDS2,QHE,SHE,VPKK,VPXE,VPXK,VPXX,VXEK
20	35854-Z7E-701	NUT, HEX., 6MM	2	-	-----	EDF6,EDS2,QHE,VPKK,VPXJ,VPXK,VPXX,VXEK
			2	-	0287080	EDS1,SHE,SXE,VPXE
			-	2	-----	EDS1,EDS2,QHE,SHE,VPKK,VPXE,VPXK,VPXX,VXEK
21	95701-08035-08	BOLT, FLANGE, 8X35	2	-	-----	EDF6,EDS2,QHE,VPKK,VPXJ,VPXK,VPXX,VXEK
			2	-	0287080	EDS1,SHE,SXE,VPXE
			-	2	-----	EDS1,EDS2,QHE,SHE,VPKK,VPXE,VPXK,VPXX,VXEK



E-22

CONTROL

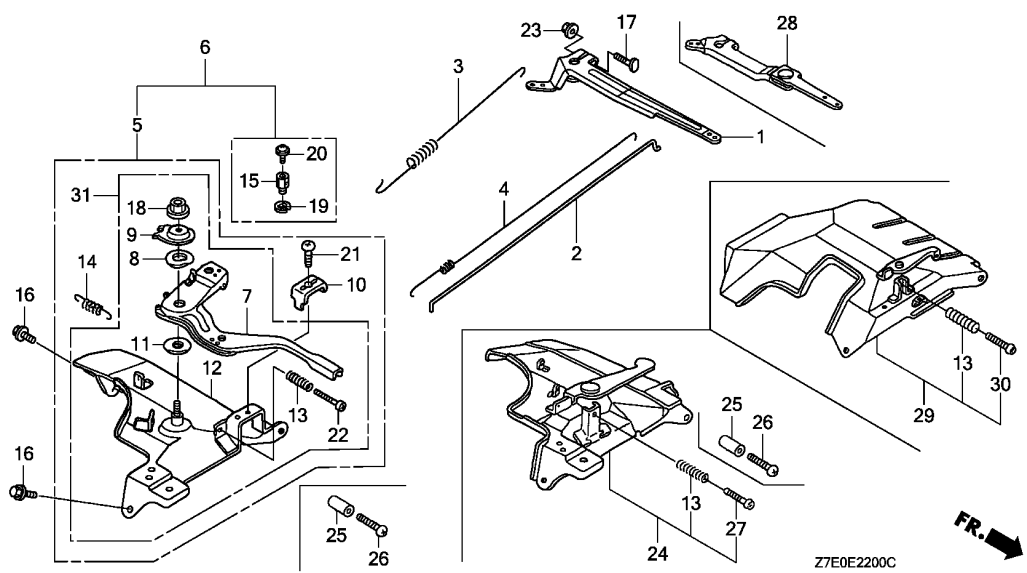

Ref. No.	L.O.N.	(Relative ref. Number) Description	F.R.T.
1		(28)	
1	1161A0	ARM, GOVERNOR	0.2
2	1161B1	ROD, GOVERNOR	0.3
3	1161C5	SPRING, GOVERNOR	0.2
4	1161C2	SPRING, THROTTLE RETURN	0.3
5		(6,24,29,31)	
5	1161A5	CONTROL, THROTTLE/GOVERNOR ...	0.2
7	1161A8	LEVER, CONTROL	0.3
12	1161A2	BASE, CONTROL	0.3

Ref. No.	Part No.	Description	Reqd. QTY		Serial No.	Parts catalogue code
			GX 390 H1	GX 390 H2		
1	16551-ZE3-000	ARM, GOVERNOR	1	1	-----	LH,LH1,LH2,LHB5,LHP1,LXE9,PX,QA2,QBE1,QEBR,QH,QH1,QHB1,QHB3,QHB5,QHBR,QHE,QHP1,QMH,QN,QP,QX,QXBR,QXE,QXEK,QXHQ,QXK,SH,SH1,SHE,SM11,SWE2,SWX2,SX,SX1,SXC,SXC1,SXE,SXE1,VPKK,VPX4,VPXB,VPXE,VPXJ,VPXK,VPXX,VSP,VTE5,VX,VX1,VX1M,VXE,VXEK,VXEM,VXK,VXKS,VXU1
2	16555-ZE3-000	ROD, GOVERNOR	1	1	-----	EDF6
3	16561-ZK6-D70	SPRING, GOVERNOR	1	-	-----	EDS1,EDS2,EDT1,ES2,ES3S,ES4S,LH,LH1,LH2,LHB5,LHP1,LXE9,PX,QA2,QBE1,QEBR,QH,QH1,QHB1,QHB3,QHB5,QHBR,QHE,QHP1,QMH,QN,QP,QX,QXBR,QXE,QXEK,QXHQ,QXK,SH,SH1,SHE,SM11,SWE2,SWX2,SX,SX1,SXC,SXC1,SXE,SXE1,VMQ3,VMT3,VS4,VS6,VS4,VS6,VTE5
	16561-ZE3-000	SPRING, GOVERNOR(L=137.5MM) -	1	-	-----	VPKK,VPX4,VPXB,VPXE,VPXJ,VPXK,VPXX,VXEK,VXKS
	16561-ZE3-710	SPRING, GOVERNOR(L=132.0MM) -	1	-	-----	VSP,VXK,VXU1
	16561-ZF6-T21	SPRING, GOVERNOR	1	-	-----	VX,VX1,VX1M,VXE,VXEM
	16561-ZF6-W32	-	1	-----	EDS1,EDS2,EDT1,ES2,ES3S,ES4S,VMQ3,VMT3,VS4,VS6,VS4,VS6,VTE5
	16561-ZK6-D70	-	1	-----	LH,LH1,PX,QH,QH1,QHE,QMH,QX,QXE,QXHQ,SH,SH1,SHE,SM11,SWX2,SX,SX1,SXC,SXC1,VTE5
	16561-ZE3-000	SPRING, GOVERNOR(L=137.5MM) -	-	1	-----	QN,VX,VX1,VX1M,VXE,VXEM
4	16562-ZE3-700	SPRING, GOVERNOR	1	1	-----	EDF6,EDS1,EDS2,EDT1,ES2,ES3S,ES4S,VMQ3,VMT3,VS4,VS6,VS4,VS6
	16562-ZE3-000	SPRING, THROTTLE RETURN	1	-	-----	LH,LH1,LH2,LHB5,LHP1,LXE9,PX,QA2,QBE1,QEBR,QH,QH1,QHB1,QHB3,QHB5,QHBR,QHE,QHP1,QMH,QN,QP,QX,QXBR,QXE,QXEK,QXHQ,QXK,SH,SH1,SHE,SM11,SWE2,SWX2,SX,SX1,SXC,SXC1,SXE,SXE1,VPKK,VPX4,VPXB,VPXE,VPXJ,VPXK,VPXX,VSP,VTE5,VX,VX1,VX1M,VXE,VXEK,VXEM,VXK,VXKS,VXU1
	16562-ZE2-700	-	1	-----	LH,LH1,PX,QH,QH1,QHE,QMH,QN,QX,QXE,QXHQ,SH1,SHE,SM11,SWX2,SX,SX1,SXC,SXC1,VPKK,VPXB,VPXE,VPXK,VPXX,VTE5,VX,VX1,VX1M,VXE,VXEK,VXEM,VXKS
5	16570-ZE3-W20	CONTROL ASSY. (REMOTE)	1	-	-----	SH
					-----	LH,LH1,LH2,LHB5,LHP1,LXE9,PX,QA2,QEBR,QH,QH1,QHB3,QHB5,QHBR,QHE,QHP1,QMH,QN,QP,QX,QXBR,QXE,QXEK,QXHQ,QXK,SH,SH1,SHE,SWE2,SWX2,SX,SX1,SXC,SXC1,SXE,SXE1

2

E-22

CONTROL

Ref. No.	Part No.	Description	Reqd. QTY		Serial No.	Parts catalogue code
			GX 390 H1	GX 390 H2		
(5)	16500-Z5T-810	CONTROL ASSY. (REMOTE) (ROD) ..	-	1	-----	LH, LH1, PX, QH, QH1, QHE, QMH, QN, QP, QX, QXE, QXHQ, SH, SH1, SHE, SWX2, SX, SX1, SXC, SXC1
6	16570-ZE3-W10	CONTROL ASSY. (REMOTE)	1	-	-----	QBE1, QHB1, SM11
	16500-Z5T-800	-	1	-----	SM11
7	16571-ZE3-W00	LEVER, CONTROL	1	1	-----	LH, LH1, LH2, LHB5, LHP1, LXE9, PX, QA2, QBE1, QEBR, QH, QH1, QHB1, QHB3, QHB5, QHBR, QHE, QHP1, QMH, QN, QP, QX, QXBR, QXE, QXEK, QXHQ, QXK, SH, SH1, SHE, SM11, SWE2, SWX2, SX, SX1, SXC, SXC1, SXE, SXE1, VTE5, VX, VX1, VX1M, VXE, VXEM
8	16574-ZE1-000	SPRING, LEVER	1	1	-----	LH, LH1, LH2, LHB5, LHP1, LXE9, PX, QA2, QBE1, QEBR, QH, QH1, QHB1, QHB3, QHB5, QHBR, QHE, QHP1, QMH, QN, QP, QX, QXBR, QXE, QXEK, QXHQ, QXK, SH, SH1, SHE, SM11, SWE2, SWX2, SX, SX1, SXC, SXC1, SXE, SXE1, VTE5, VX, VX1, VX1M, VXE, VXEM
9	16575-ZE2-W00	WASHER, CONTROL LEVER	1	1	-----	LH, LH1, LH2, LHB5, LHP1, LXE9, PX, QA2, QBE1, QEBR, QH, QH1, QHB1, QHB3, QHB5, QHBR, QHE, QHP1, QMH, QN, QP, QX, QXBR, QXE, QXEK, QXHQ, QXK, SH, SH1, SHE, SM11, SWE2, SWX2, SX, SX1, SXC, SXC1, SXE, SXE1, VTE5, VX, VX1, VX1M, VXE, VXEM
10	16576-891-000	HOLDER, CABLE	1	1	-----	LH, LH1, LH2, LHB5, LHP1, LXE9, PX, QA2, QBE1, QEBR, QH, QH1, QHB1, QHB3, QHB5, QHBR, QHE, QHP1, QMH, QN, QP, QX, QXBR, QXE, QXEK, QXHQ, QXK, SH, SH1, SHE, SM11, SWE2, SWX2, SX, SX1, SXC, SXC1, SXE, SXE1
11	16578-ZE1-000	SPACER, CONTROL LEVER	1	1	-----	LH, LH1, LH2, LHB5, LHP1, LXE9, PX, QA2, QBE1, QEBR, QH, QH1, QHB1, QHB3, QHB5, QHBR, QHE, QHP1, QMH, QN, QP, QX, QXBR, QXE, QXEK, QXHQ, QXK, SH, SH1, SHE, SM11, SWE2, SWX2, SX, SX1, SXC, SXC1, SXE, SXE1, VTE5, VX, VX1, VX1M, VXE, VXEM
12	16581-ZE3-W00	BASE COMP., CONTROL(###)	1	-	-----	LH, LH1, LH2, LHB5, LHP1, LXE9, PX, QA2, QBE1, QEBR, QH, QH1, QHB1, QHB3, QHB5, QHBR, QHE, QHP1, QMH, QN, QP, QX, QXBR, QXE, QXEK, QXHQ, QXK, SH, SH1, SHE, SM11, SWE2, SWX2, SX, SX1, SXC, SXC1, SXE, SXE1, VTE5, VX, VX1, VX1M, VXE, VXEM
	16580-Z5T-000	BASE COMP., CONTROL	-	1	-----	LH, LH1, PX, QH, QH1, QHE, QMH, QN, QP, QX, QXE, QXHQ, SH, SH1, SHE, SM11, SWX2, SX, SX1, SXC, SXC1, VTE5, VX, VX1, VX1M, VXE, VXEM
13	16584-883-300	SPRING, CONTROL ADJUSTING ...	1	1	-----	
14	16592-883-310	SPRING, CABLE RETURN	1	1	-----	LH, LH1, LH2, LHB5, LHP1, LXE9, PX, QA2, QBE1, QEBR, QH, QH1, QHB1, QHB3, QHB5, QHBR, QHE, QHP1, QMH, QN, QP, QX, QXBR, QXE, QXEK, QXHQ, QXK, SH, SH1, SHE, SM11, SWE2, SWX2, SX, SX1, SXC, SXC1, SXE, SXE1
15	16594-883-010	HOLDER, WIRE	1	1	-----	QBE1, QHB1, SM11
16	90013-883-000	BOLT, FLANGE, 6X12(CT200) ...	2	2	-----	
17	90015-ZE5-010	BOLT, GOVERNOR ARM	1	1	-----	
18	90114-SA0-000	NUT, SELF-LOCK, 6MM	1	1	-----	LH, LH1, LH2, LHB5, LHP1, LXE9, PX, QA2, QBE1, QEBR, QH, QH1, QHB1, QHB3, QHB5, QHBR, QHE, QHP1, QMH, QN, QP, QX, QXBR, QXE, QXEK, QXHQ, QXK, SH, SH1, SHE, SM11, SWE2, SWX2, SX, SX1, SXC, SXC1, SXE, SXE1, VTE5, VX, VX1, VX1M, VXE, VXEM
	90202-Z1T-000	1	-	-----	LH1, LH2, LHB5, LHP1, LXE9, PX, QBE1, QEBR, QH1, QHB1, QHB3, QHB5, QHBR, QHE, QHP1, QMH, QN, QP, QX, QXBR, QXE, QXEK, QXK, SH1, SWE2, SWX2, SX1, SXC1, SXE1, VTE5, VX, VX1, VX1M, VXE, VXEM
			1	-	0166525	LH, QA2, QH, QXHQ, SH, SHE, SX, SXC, SXE
			1	-	0169782	SM11
19	90605-230-000	CIRCLIP, 5MM	1	1	-----	QBE1, QHB1, SM11
	90605-Z1T-000	1	-	-----	QBE1, QHB1, SM11
20	93500-04006-0H	SCREW, PAN, 4X6	1	1	-----	QBE1, QHB1, SM11
21	93500-05016-0A	SCREW, PAN, 5X16	1	1	-----	LH, LH1, LH2, LHB5, LHP1, LXE9, PX, QA2, QBE1, QEBR, QH, QH1, QHB1, QHB3, QHB5, QHBR, QHE, QHP1, QMH, QN, QP, QX, QXBR, QXE, QXEK, QXHQ, QXK, SH, SH1, SHE, SM11, SWE2, SWX2, SX, SX1, SXC, SXC1, SXE, SXE1
22	93500-05032-0A	SCREW, PAN, 5X32	1	1	-----	LH, LH1, LH2, LHB5, LHP1, LXE9, PX, QA2, QBE1, QEBR, QH, QH1, QHB1, QHB3, QHB5, QHBR, QHE, QHP1, QMH, QN, QP, QX, QXBR, QXE, QXEK, QXHQ, QXK, SH, SH1, SHE, SM11, SWE2, SWX2, SX, SX1, SXC, SXC1, SXE, SXE1, VTE5, VX, VX1, VX1M, VXE, VXEM
23	94050-06000	NUT, FLANGE, 6MM	1	1	-----	
24	16570-ZE3-721	CONTROL ASSY.	1	-	-----	VPKK, VPX4, VPXB, VPXE, VPXJ, VPXK, VPXX, VSP, VXK, VXU1
	16500-Z5T-870	-	1	-----	VPKK, VPXB, VPXE, VPXK, VPXX
25	16599-ZG1-M10	COLLAR, STOPPER	(1)	(1)	-----	QHB1, VPKK, VPX4, VPXB, VPXE, VPXJ, VPXK, VPXX, VXEK, VXKS
26	90016-ZG9-N30	SCREW, RECESSED, 5X25	(1)	(1)	-----	QHB1, VPKK, VPX4, VPXB, VPXE, VPXJ, VPXK, VPXX, VXEK, VXKS



E-22

CONTROL

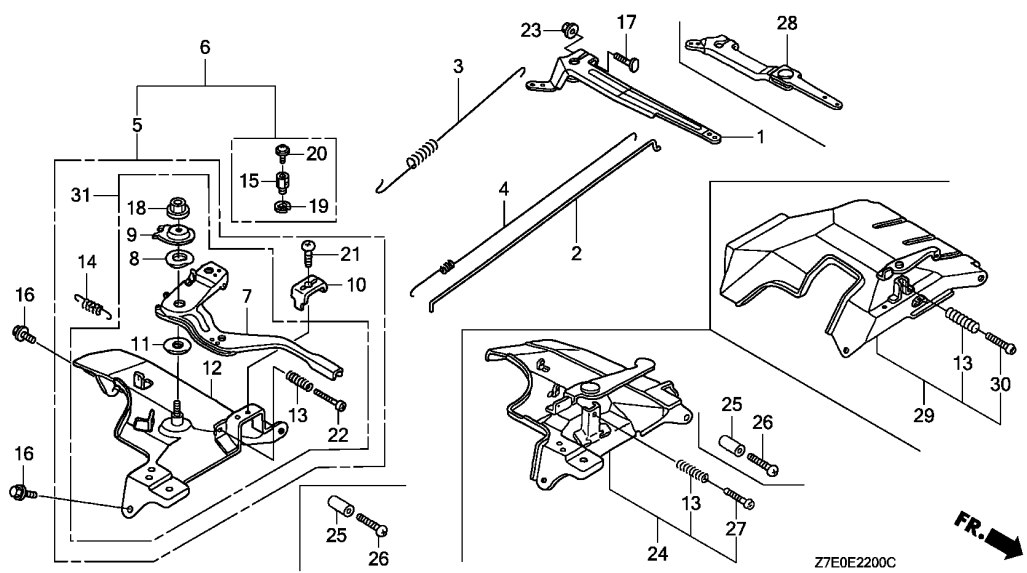

Ref. No.	Part No.	Description	Reqd. QTY		Serial No.	Parts catalogue code
			GX 390 H1	GX 390 H2		
27	93500-05045-0A	SCREW, PAN, 5X45	1	1	-----	VPKK,VPX4,VPXB,VPXE,VPXJ,VPXK,VPXX,VSP,VXK,VXU1
28	16550-ZE3-700	ARM COMP., GOVERNOR	1	1	-----	EDF6,EDS1,EDS2,EDT1,ES2,ES3S,ES4S,VMQ3,VMT3,VS4,VS6,USB4
29	16570-ZE3-710	CONTROL ASSY.	1	-	-----	EDF6,EDS1,EDS2,EDT1,ES2,ES3S,ES4S,VMQ3,VMT3,VS4,VS6,USB4
	16570-ZE3-700	1	-	0840494	VXEK,VXKS
	16500-Z5T-890	-	1	-----	VXEK,VXKS
	16500-Z5T-880	-	1	-----	EDS1,EDS2,EDT1,ES2
30	93500-05035-0A	SCREW, PAN, 5X35	1	1	-----	VXEK,VXKS
					-----	EDF6,EDS1,EDS2,EDT1,ES2,ES3S,ES4S,VMQ3,VMT3,VS4,VS6,USB4,VXEK,VXKS
31	16570-ZE3-W00	CONTROL ASSY. (STD.)	1	-	-----	VTE5,VX,VX1,VX1M,VXE,VXEM
	16500-Z5T-000	-	1	-----	VTE5,VX,VX1,VX1M,VXE,VXEM

2

E-22-20

AUTO THROTTLE

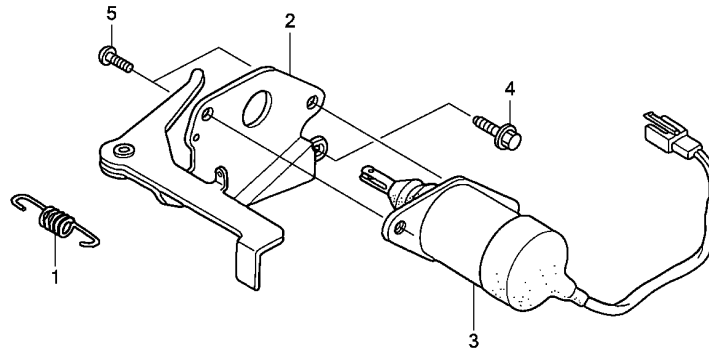

Z7E0E2220

Ref. No.	L.O.N.	(Relative ref. Number) Description	F.R.T.
1	8101Q9	SPRING, CHOKE RETURN	0.1
2	8101H1	LEVER, THROTTLE	0.2
3	6211C5	SOLENOID, AUTO THROTTLE	0.3

Ref. No.	Part No.	Description	Reqd. QTY		Serial No.	Parts catalogue code
			GX 390 H1	GX 390 H2		
1	16268-893-000	SPRING, CHOKE RETURN	1	-	-----	VMQ3,VMT3
2	17850-ZD1-E30	LEVER COMP., THROTTLE	1	-	-----	VMQ3,VMT3
3	36160-ZB4-013	SOLENOID ASSY.	1	-	-----	VMQ3,VMT3
4	90013-883-000	BOLT, FLANGE, 6X12(CT200) ...	1	-	-----	VMQ3,VMT3
5	93500-05008-0A	SCREW, PAN, 5X8	2	-	-----	VMQ3,VMT3

E-23

CONTROL BOX

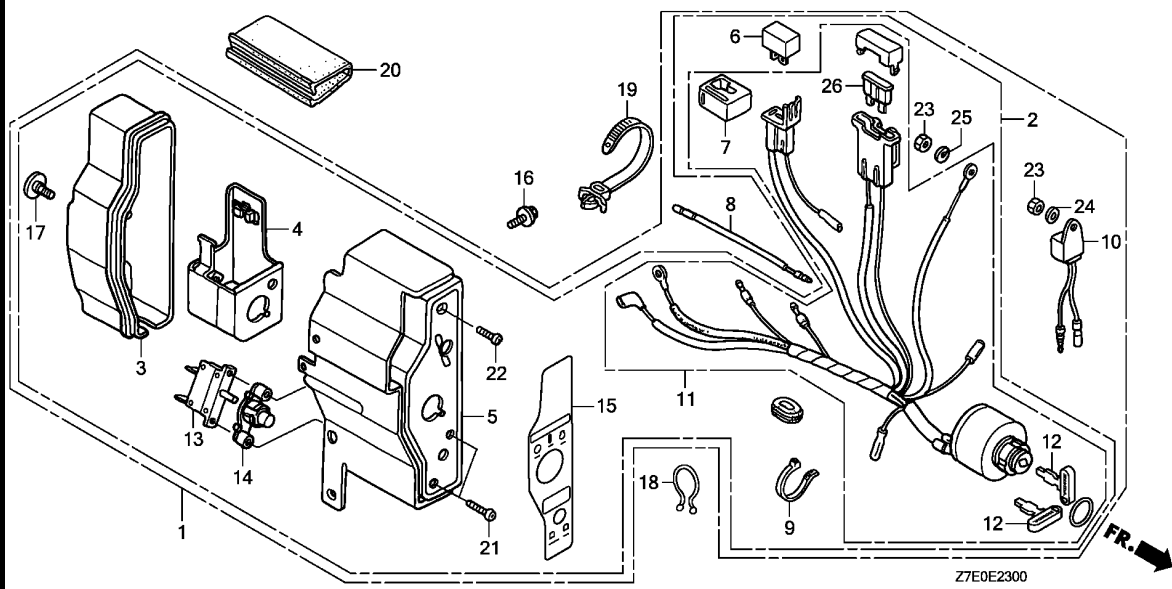

Ref. No.	L.O.N.	(Relative ref. Number) Description	F.R.T.
1		(2)	
1	6221N7	BOX, ENGINE CONTROL	0.1
5	6221P7	PANEL, ENGINE CONTROL	0.2
6	6131B8	RECTIFIER, SILICON	0.2
10	6151K4	ALERT UNIT, ENGINE CONTROL OIL	0.2
11	6151E1	SWITCH, COMBINATION	0.2
13	6221D4	PROTECTOR, CIRCUIT	0.2
26	8121A7	FUSE, BLADE	0.1

Ref. No.	Part No.	Description	Reqd. QTY		Serial No.	Parts catalogue code
			GX 390 H1	GX 390 H2		
1	31610-Z5T-803ZA	BOX ASSY., CONTROL(EXP-ALERT) *R280*.....POWER RED	1	-	----- LXE9	
	31610-ZE3-W14ZE	BOX ASSY., CONTROL(ALERT) *R280*.....POWER RED	1	-	----- QEBR,QXE,QXEK,SXE,SXE1,VMT3,VTE5,VXE,VXEM,VXK,VXU1	
2	31610-ZE3-812ZD	BOX ASSY., CONTROL *R280*.....POWER RED	1	-	----- QBE1,QHE,SHE,SWE2	
	31610-Z5T-811ZA	BOX ASSY., CONTROL(EXTERNAL) *NH1*.....BLACK	-	1	----- QHE,QXE,SHE,VTE5,VXE,VXEM	
	31610-Z5T-811ZB	*R280*.....POWER RED	-	1	----- QHE,QXE,SHE,VTE5,VXE,VXEM	
3	31612-ZE2-003	CASE, CONTROL	1	1	----- LXE9,QBE1,QEBR,QHE,QXE,QXEK,SHE,SWE2,SXE,SXE1,VMT3,VTE5,VXE,VXEM,VXK,VXU1	
4	31614-ZE2-003	BRACKET, CASE MOUNTING	1	1	----- LXE9,QBE1,QEBR,QHE,QXE,QXEK,SHE,SWE2,SXE,SXE1,VMT3,VTE5,VXE,VXEM,VXK,VXU1	
5	31615-ZE3-003ZE	PANEL COMP., CONTROL *R280*.....POWER RED	1	1	----- LXE9,QBE1,QEBR,QHE,QXE,QXEK,SHE,SWE2,SXE,SXE1,VMT3,VTE5,VXE,VXEM,VXK,VXU1	
	31615-ZE3-003ZA	*NH1*.....BLACK	-	1	----- QHE,QXE,SHE,VTE5,VXE,VXEM	
6	31700-124-008	RECTIFIER ASSY., SILICON (SHINDENGEN)	1	1	----- LXE9,QBE1,QEBR,QHE,QXE,QXEK,SHE,SWE2,SXE,SXE1,VMT3,VTE5,VXE,VXEM,VXK,VXU1	
7	32127-738-700	SUSPENSION, COUPLER	1	1	----- LXE9,QBE1,QEBR,QHE,QXE,QXEK,SHE,SWE2,SXE,SXE1,VMT3,VTE5,VXE,VXEM,VXK,VXU1	
8	32197-ZE1-003	HARNESS, SUB WIRE	1	-	----- LXE9,QEBR,QXE,QXEK,SXE,SXE1,VMT3,VTE5,VXE,VXEM,VXK,VXU1	
9	32902-892-003	BAND	1	1	----- LXE9,QBE1,QEBR,QHE,QXE,QXEK,SHE,SWE2,SXE,SXE1,VMT3,VTE5,VXE,VXEM,VXK,VXU1	
10	34150-ZH7-023	ALERT UNIT, OIL	1	-	----- LXE9,QEBR,QXE,QXEK,SXE,SXE1,VMT3,VTE5,VXE,VXEM,VXK,VXU1	

E-23

CONTROL BOX

Ref. No.	Part No.	Description	Reqd. QTY		Serial No.	Parts catalogue code
			GX 390 H1	GX 390 H2		
11	35100-ZE2-033	SWITCH ASSY., COMBINATION ...	1	-	-----	LXE9,QBE1,QEBR,QHE,QXE,QXEK,SHE,SWE2,SXE,SXE1,VMT3,VTE5,VXE,VXEM,VXK VXU1
	35100-Z5T-811	-	1	-----	QHE,QXE,SHE,VTE5,VXE,VXEM
12	35111-880-013	KEY COMP.(HONDA LOCK)	2	2	-----	LXE9,QBE1,QEBR,QHE,QXE,QXEK,SHE,SWE2,SXE,SXE1,VMT3,VTE5,VXE,VXEM,VXK VXU1
13	38240-VA3-900	PROTECTOR, CIRCUIT(1.0A)	1	1	-----	LXE9,QBE1,QEBR,QHE,QXE,QXEK,SHE,SWE2,SXE,SXE1,VMT3,VTE5,VXE,VXEM,VXK VXU1
14	38250-ZA8-701	LENS ASSY., PROTECTOR	1	1	-----	LXE9,QBE1,QEBR,QHE,QXE,QXEK,SHE,SWE2,SXE,SXE1,VMT3,VTE5,VXE,VXEM,VXK VXU1
15	87529-Z4T-840	MARK, CONTROL BOX(EXTERNAL) -	1	-	-----	LXE9
	87529-ZE2-812	MARK, CONTROL BOX(EXP)	1	-	-----	QBE1,QEBR,QHE,QXE,QXEK,SHE,SWE2,SXE,SXE1,VMT3,VTE5,VXE,VXEM,VXK,VXU1
	87529-Z4T-840	MARK, CONTROL BOX(EXTERNAL) -	-	1	-----	QHE,QXE,SHE,VTE5,VXE,VXEM
16	90013-883-000	BOLT, FLANGE, 6X12(CT200) ...	2	2	-----	LXE9,QBE1,QEBR,QHE,QXE,QXEK,SHE,SWE2,SXE,SXE1,VMT3,VTE5,VXE,VXEM,VXK VXU1
17	90380-MA6-010	SCREW, SPECIAL, 6X12	1	1	-----	LXE9,QBE1,QEBR,QHE,QXE,QXEK,SHE,SWE2,SXE,SXE1,VMT3,VTE5,VXE,VXEM,VXK VXU1
18	90630-751-000	CLIP, PURSE LOCK	1	1	-----	LXE9,QBE1,QEBR,QHE,QXE,QXEK,SHE,SWE2,SXE,SXE1,VMT3,VTE5,VXE,VXEM,VXK VXU1
19	90672-SA0-003	STRAP, CABLE, 118MM(BLACK) ..	1	1	-----	LXE9,QBE1,QEBR,QHE,QXE,QXEK,SHE,SWE2,SXE,SXE1,VMT3,VTE5,VXE,VXEM,VXK VXU1
20	91406-ZE2-003	TUBE, FASTENER, 30MM	1	1	-----	LXE9,QBE1,QEBR,QHE,QXE,QXEK,SHE,SWE2,SXE,SXE1,VMT3,VTE5,VXE,VXEM,VXK VXU1
21	93500-03012-0H	SCREW, PAN, 3X12	2	2	-----	LXE9,QBE1,QEBR,QHE,QXE,QXEK,SHE,SWE2,SXE,SXE1,VMT3,VTE5,VXE,VXEM,VXK VXU1
22	93500-04012-0H	SCREW, PAN, 4X12	1	-	-----	LXE9,QBE1,QEBR,QHE,QXE,QXEK,SHE,SWE2,SXE,SXE1,VMT3,VTE5,VXE,VXEM,VXK VXU1
23	94001-04390-0S	NUT, HEX., 4MM	2	-	-----	LXE9,QEBR,QXE,QXEK,SXE,SXE1,VMT3,VTE5,VXE,VXEM,VXK,VXU1
			1	-	-----	QBE1,QHE,SHE,SWE2
24	94101-04800	WASHER, PLAIN, 4MM	1	-	-----	LXE9,QEBR,QXE,QXEK,SXE,SXE1,VMT3,VTE5,VXE,VXEM,VXK,VXU1
25	94111-04800	WASHER, SPRING, 4MM	1	-	-----	LXE9,QBE1,QEBR,QHE,QXE,QXEK,SHE,SWE2,SXE,SXE1,VMT3,VTE5,VXE,VXEM,VXK VXU1
26	98200-30500	FUSE, BLADE(5A)	1	1	-----	LXE9,QBE1,QEBR,QHE,QXE,QXEK,SHE,SWE2,SXE,SXE1,VMT3,VTE5,VXE,VXEM,VXK VXU1



E-26

REDUCTION(1/2)

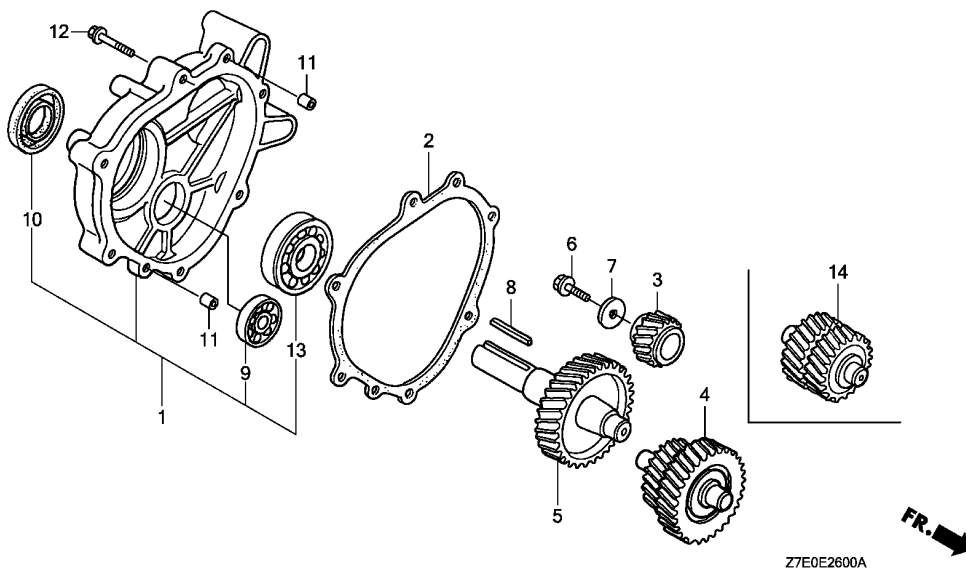

Ref. No.	L.O.N.	(Relative ref. Number) Description	F.R.T.
1		(2)	
2141AL		REDUCTION COVER AND/OR PACKING (L-TYPE)	0.2
3	2141L2	GEAR, PRIMARY DRIVE	0.2
4		(14)	
2141AK		COUNTERSHAFT, REDUCTION (L-TYPE)	0.2
5	2141V7	SHAFT, POWER TAKE OFF(L-TYPE)	0.2
9	2141AJ	BEARING, REDUCTION COUNTERSHAFT(L-TYPE) :REAR ..	0.3
10	2141X3	OIL SEAL, POWER TAKE OFF SHAFT (L-TYPE) :REAR	0.3
13	2141X8	BEARING, POWER TAKE OFF SHAFT (L-TYPE) :REAR	0.3

Ref. No.	Part No.	Description	Reqd. QTY		Serial No.	Parts catalogue code
			GX 390 H1	GX 390 H2		
1	11500-Z7E-020	COVER ASSY., GEAR CASE	1	1	-----	LH,LH1,LH2,LHB5,LHP1,LXE9
2	11521-Z7B-701	PACKING, CHAIN CASE COVER (NINGBO SIL GASKET)	1	1	-----	LH,LH1,LH2,LHB5,LHP1,LXE9
	11521-ZE2-800	PACKING, CHAIN CASE COVER ...	1	1	-----	LH,LH1,LH2,LHB5,LHP1,LXE9
3	22103-ZE3-610	GEAR, PRIMARY DRIVE(22T) ...	1	1	-----	LH,LH1,LH2,LHB5,LXE9
	22103-ZE3-W00	GEAR, PRIMARY DRIVE(BANKA) (27T)	1	-	-----	LHP1
4	23220-ZE3-610	COUNTERSHAFT COMP.(21T/27T) -	1	1	-----	LH,LH1,LH2,LHB5,LXE9
5	23710-ZE3-610	SHAFT, P.T.O.(33T)	1	1	-----	LH,LH1,LH2,LHB5,LXE9
	23710-ZF6-Y30	SHAFT, P.T.O.(HPI)(33T)	1	-	-----	LHP1
6	90107-959-003	BOLT, FLANGE, 8X25	1	1	-----	LH,LH1,LH2,LHB5,LHP1,LXE9
7	90473-ZE3-010	WASHER, 8.5X42X4.5	1	1	-----	LH,LH1,LH2,LHB5,LHP1,LXE9
8	90741-805-000	KEY, 7X7X33	1	1	-----	LH,LH1,LH2,LHB5,LXE9
	90741-889-810	KEY, 7X7X33(YELLOW)(O.S.) ...	(1)	(1)	-----	LH,LH1,LH2,LHB5,LXE9
	90745-ZK2-800	KEY, 6.3X6.3X33	1	-	-----	LHP1
9	91009-KJ1-003	BEARING, RADIAL BALL, 6202 (NTN)	1	1	-----	LH,LH1,LH2,LHB5,LHP1,LXE9
10	91201-Z7B-003	OIL SEAL, 30X46X8	1	1	-----	LH,LH1,LH2,LHB5,LHP1,LXE9
11	94301-08140	DOWEL PIN, 8X14	2	2	-----	LH,LH1,LH2,LHB5,LHP1,LXE9
12	95701-08040-00	BOLT, FLANGE, 8X40	6	6	-----	LH,LH1,LH2,LHB5,LHP1,LXE9
13	91001-Z7B-003	BEARING, RADIAL BALL, 6206 ..	1	1	-----	LH,LH1,LH2,LHB5,LHP1,LXE9
	96100-62060-00	1	1	-----	LH,LH1,LH2,LHB5,LHP1,LXE9
14	23222-ZE3-W00	GEAR, COUNTER(BANKA)(21T) ...	1	-	-----	LHP1

E-28

LABEL

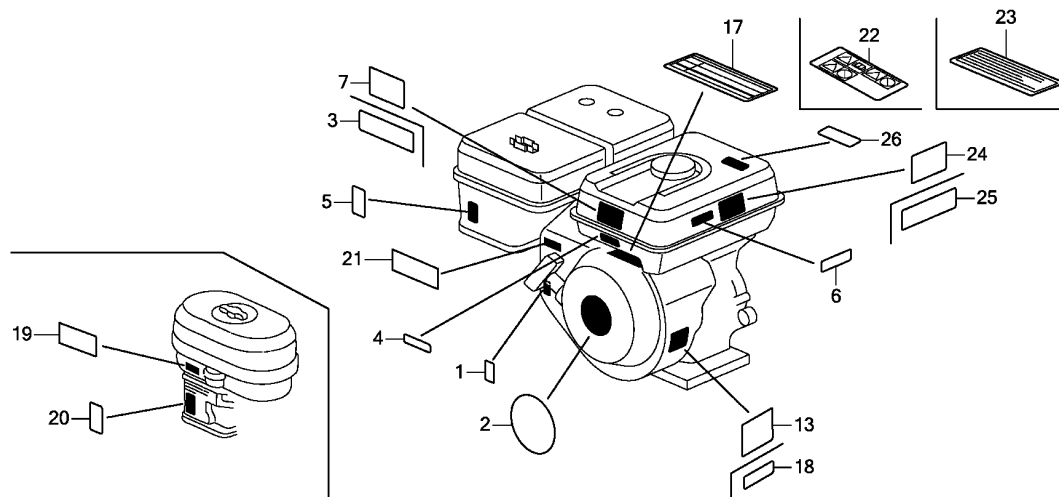

Z7E0E2800L

Ref. L.O.N. (Relative ref. Number) F.R.T.
No. Description

NO INFORMATION

Ref. No.	Part No.	Description	Reqd. QTY		Serial No.	Parts catalogue code
			GX 390 H1	GX 390 H2		
1	87114-ZH7-000	LABEL, WARNING (NOT CERTIFIED FOR SALE)	1	1	-----	EDF6,EDS1,EDS2,EDT1,ES2,ES3S,ES4S,LH,LH1,LH2,LHB5,LHP1,LXE9,PX,QA2,QEBR,QH,QH1,QHB3,QHB5,QHBR,QHE,QHP1,QMH,QN,QP,QX,QXBR,QXE,QXEK,QXHQ,QXK,SH,SH1,SHE,SM11,SWE2,SWX2,SX,SX1,SXC,SXC1,SXE,SXE1,VMQ3,VMT3,VPKK,VPX4,VPXB,VPXE,VPXJ,VPXK,VPXX,VS4,VS6,USB4,VTE5,VX,VX1,VX1M,VXE,VXEK,VXEM,VXK,VXKS,VXU1
	87114-ZH7-840	1	-	-----	QBE1,QHB1,VSP
2	87521-ZF6-W04	EMBLEM(HONDA GX390)	1	1	-----	EDF6,EDS1,EDS2,EDT1,LH,LH1,LH2,LHB5,LXE9,PX,QA2,QBE1,QEBR,QH,QH1,QHB1,QHB3,QHB5,QHBR,QHE,QHP1,QMH,QN,QP,QX,QXBR,QXE,QXEK,QXHQ,QXK,SH,SH1,SHE,SM11,SWE2,SWX2,SX,SX1,SXC,SXC1,SXE,SXE1,VMQ3,VMT3,VPKK,VPX4,VPXB,VPXE,VPXJ,VPXK,VPXX,VSP,VTE5,VX,VX1,VX1M,VXE,VXEK,VXEM,VXK,VXKS,VXU1
3	87522-Z1T-G21	LABEL, CAUTION	1	-	-----	LH1,LHB5,LHP1,PX,QH1,QHB3,QHB5,QHP1,QMH,QN,QP,QX,QXE,SH1,SX1,SXC1,SXE1,VX1,VXE,VXU1
	87516-Z1T-800	MARK, OPERATOR CAUTION(KOREAN)	1	-	-----	LXE9,QXEK,QXK,VXK
	87516-ZK6-810	MARK, OPERATOR CAUTION (CHINESE)(MADE IN CHINA)	1	-	-----	QA2,QXHQ
	87522-ZH9-010	LABEL, CAUTION(ENGLISH, ETC.)	1	-	0051201	LH,QH,SH,SHE,SX,SXC,SXE,VX
4	87522-Z1T-J00	LABEL, CAUTION(CHINESE)	1	-	0051201	LH,QH,SH,SHE,SM11,SX,SXC,SXE,VX
	87528-Z7E-000	MARK, CHOKE	1	-	0000149	0051201 VPX4
	87528-ZH7-000	MARK, CHOKE(GRAY)	1	-	-----	LH,LH1,LH2,LHB5,LHP1,PX,QA2,QEBR,QH,QH1,QHB3,QHB5,QHBR,QHE,QHP1,QMH,QN,QX,QXBR,QXE,QXEK,QXHQ,QXK,SH,SH1,SHE,SM11,SX,SX1,SXC,SXC1,SXE,SXE1,VTE5,VX,VX1,VX1M,VXE,VXEM,VXK,VXU1
	87528-Z7E-000	MARK, CHOKE	-	1	-----	LXE9,VSP
					-----	LH,LH1,PX,QH,QH1,QHE,QMH,QN,QX,QXE,QXHQ,SH,SH1,SHE,SM11,SWX2,SX,SX1,SXC,SXC1,VTE5,VX,VX1,VX1M,VXE,VXEM
6	87532-ZH8-810	MARK, OIL ALERT(ENGLISH)	1	-	-----	PX,QX,QXE,QXEK,QXK,SWX2,SX1,SXC1,SXE1,VX1,VXE,VXK,VXU1
	87532-ZK7-800	MARK, OIL ALERT	1	-	-----	QEBR,QXBR
	87532-Z7E-010	1	-	-----	QXHQ,VPXB



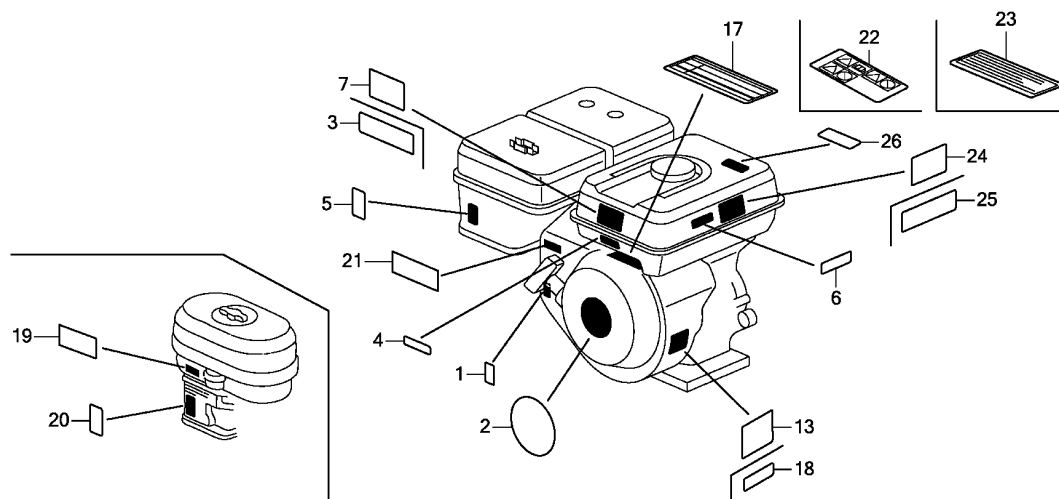

Z7E0E2800L

Ref. No.	Part No.	Description	Reqd. QTY		Serial No.	Parts catalogue code
			GX 390 H1	GX 390 H2		
(6)	87532-Z7E-000	MARK, OIL ALERT	1	-	0011784	SX,SXC,SXE,VPX4,VX
	87532-Z7E-010	1	-	0011785	SX,SXC,SXE,VPX4,VX
7	87516-Z1V-800	MARK, OPERATOR CAUTION	1	-		LH2,SWE2,SWX2
	87519-Z4N-000	MARK, OPERATOR CAUTION (PICTOGRAPH)	1	-		QBE1,QEBR,QHB1,QHBR,QXBR,VSP
	87516-ZH7-000	MARK, OPERATOR CAUTION (ENGLISH)(MADE IN JAPAN)	1	-		VPX4
	87516-ZH7-810	MARK, OPERATOR CAUTION (PICTOGRAPH)(MADE IN JAPAN)	(1)	-		VPX4
	87516-ZCL-800	MARK, OPERATOR CAUTION(KOREA)	1	-		VXEK,VXKS
	87516-ZK6-810	MARK, OPERATOR CAUTION (CHINESE)(MADE IN CHINA)	1	-	0051202	LH,QH,SH,SHE,SM11,SX,SXC,SXE,VX
	87516-Z4N-000	MARK, OPERATOR CAUTION (ENGLISH)(MADE IN CHINA)	1	-	0053889	VSP
	87516-Z4N-810	MARK, OPERATOR CAUTION (PICTOGRAPH)(MADE IN CHINA)	(1)	-	0053889	VSP
13	87594-ZB4-A00	MARK, OIL CAUTION	1	1		EDF6,EDS1,EDS2,EDT1
17	87516-Z1V-800	MARK, OPERATOR CAUTION	1	1		ES2
	87516-ZK6-810	MARK, OPERATOR CAUTION (CHINESE)(MADE IN CHINA)	1	-		VPXB,VPXE,VPXJ,VPXK
			1	-	0051202	VPX4
	87516-ZCL-800	MARK, OPERATOR CAUTION(KOREA)	-	1		VXEK,VXKS
18	87532-ZH8-810	MARK, OIL ALERT(ENGLISH)	1	1		VPKK,VPXX,VX1M,VXEM
	87532-Z7E-010	MARK, OIL ALERT	1	-		VPXE,VPXJ,VPXK
			-	1		VPXB,VPXE,VPXK
19	87524-Z0S-801	MARK, AIR CLEANER CAUTION (OIL BATH)	1	1		SWE2,SWX2
	87524-Z0T-800	1	-		QP
20	87528-ZH7-000	MARK, CHOKE(GRAY)	1	-		QBE1,QHB1

E-28

LABEL

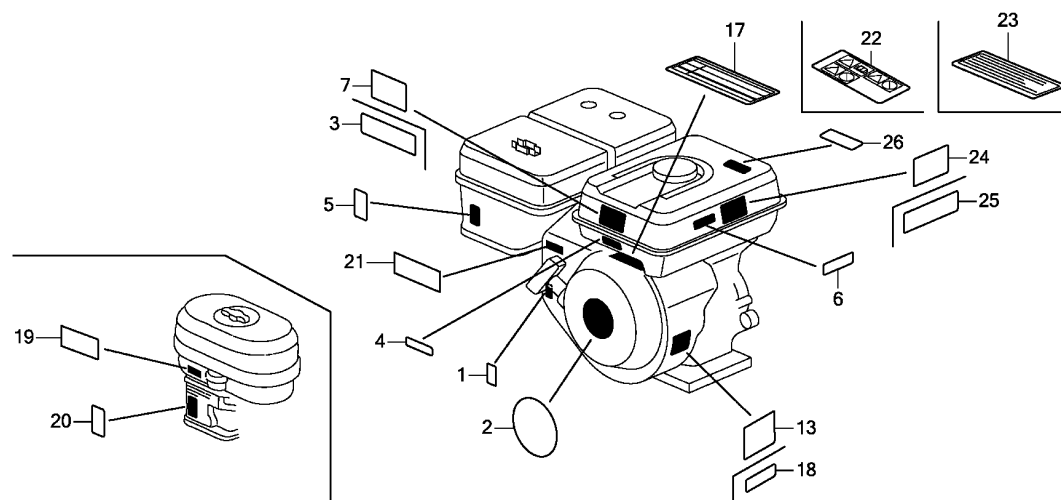

Z7E0E2800L

Ref. No.	Part No.	Description	Reqd. QTY		Serial No.	Parts catalogue code
			GX 390 H1	GX 390 H2		
20)	87528-Z7E-000	MARK, CHOKE	1	-	----- QP,SWE2,SWX2	
21	87532-ZH7-000	MARK, THROTTLE INDICATION ...	1	-	----- LXE9,QBE1,QHB1	
22	87519-Z4N-000	MARK, OPERATOR CAUTION (PICTOGRAPH)	1	1	----- VPKK,VPXX	
23	87522-Z1T-G21	LABEL, CAUTION	1	-	----- VX1M,VXEM	
24	87516-Z1V-800	MARK, OPERATOR CAUTION	-	1	----- SWX2	
25	87522-Z1T-G21	LABEL, CAUTION	-	1	----- LH1,PX,QH1,QMH,QN,QX,QXE,SH1,SX1,SXC1,VX1,VX1M,VXE,VXEM	
26	87532-ZH8-810	MARK, OIL ALERT(ENGLISH)	-	1	----- PX,QX,QXE,SWX2,SX1,SXC1,VX1,VXE	
	87532-Z7E-010	MARK, OIL ALERT	-	1	----- QXHQ,SX,SXC,VX	

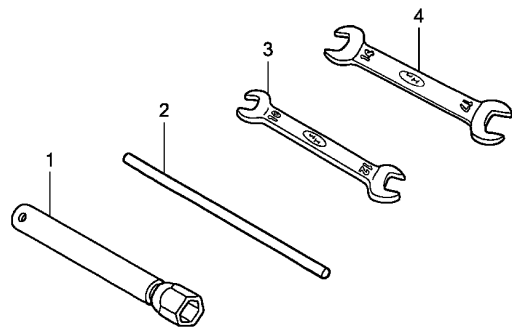

Z7E0E2900A

Ref. L.O.N. (Relative ref. Number) F.R.T.
No. Description

NO INFORMATION

Ref. No.	Part No.	Description	Reqd. QTY		Serial No.	Parts catalogue code
			GX 390 H1	GX 390 H2		
1	89218-ZE1-000	WRENCH COMP., SPARK PLUG	1	1	-----	LHB5,LHP1,QA2,QHB3,QHB5,QHP1,QMH,QN,QP,SM11,SWX2,VPKK,VPXX,USB4
	99004-21002	WRENCH, BOX (P21)	1	-	-----	EDF6
2	89219-805-000	HANDLE, BOX WRENCH	1	1	-----	LHB5,LHP1,QHB3,QHB5,QHP1,QMH,QN,QP,SM11,SWX2,VPKK,VPXX,USB4
3	99001-10120	SPANNER, 10X12	1	1	-----	QN
4	99001-14170	SPANNER, 14X17	1	1	-----	QN

E-40

FUEL COCK/COMBINATION SWITCH

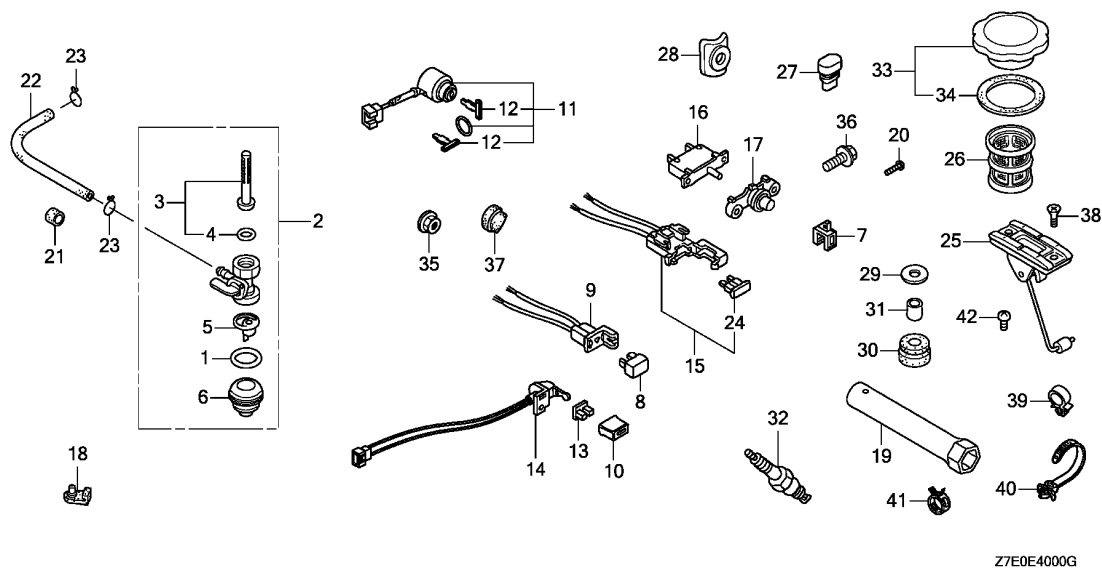

Ref. No.	L.O.N.	(Relative ref. Number) Description	F.R.T.
25	6171A1	METER/GAUGE UNIT, FUEL (34)	0.1
33	3101M7	CAP, FUEL FILLER	0.1

Ref. No.	Part No.	Description	Reqd. QTY		Serial No.	Parts catalogue code
			GX 390 H1	GX 390 H2		
1	16173-001-004	O-RING	1	1	EDS1,EDS2,EDT1,ES2,ES3S,ES4S,VMQ3,VMT3,VS4,VS6,VS4	
2	16950-ZB4-015	COCK ASSY., FUEL	1	1	EDS1,EDS2,EDT1,ES2,ES3S,ES4S,VMQ3,VMT3,VS4,VS6,VS4	
3	16952-ZB4-005	SCREEN SET, FUEL STRAINER	1	1	EDS1,EDS2,EDT1,ES2,ES3S,ES4S,VMQ3,VMT3,VS4,VS6,VS4	
4	16958-397-771	O-RING, 9.0X1.3	1	1	EDS1,EDS2,EDT1,ES2,ES3S,ES4S,VMQ3,VMT3,VS4,VS6,VS4	
5	16959-471-831	FILTER, CUP	1	1	EDS1,EDS2,EDT1,ES2,ES3S,ES4S,VMQ3,VMT3,VS4,VS6,VS4	
6	16967-GA6-671	CUP, FUEL STRAINER	1	1	EDS1,EDS2,EDT1,ES2,ES3S,ES4S,VMQ3,VMT3,VS4,VS6,VS4	
7	30561-ZB4-000	CLIP, WIRE	1	1	EDS1,EDS2,EDT1	
8	31700-124-008	RECTIFIER ASSY., SILICON (SHINDENGEN)	1	1	EDF6,EDS1,EDS2	
9	32130-ZE1-000	COUPLER COMP.	1	1	EDF6,EDS1,EDS2	
10	32343-892-003	KNOB, COCK LEVER	1	1	EDT1	
11	35100-ZB4-023	SWITCH ASSY., COMBINATION (HONDA LOCK)	1	1	EDF6,EDS1,EDS2,ES4S,VS6	
12	35111-880-013	KEY COMP.(HONDA LOCK)	2	2	EDF6,EDS1,EDS2,ES4S,VS6	
13	36106-892-003	BUSH, CONTROL KNOB	1	1	EDT1	
14	36110-ZB4-702	SWITCH ASSY., ENGINE KILL	1	1	EDT1	
15	38220-ZE1-000	CASE COMP., FUSE	1	1	EDF6,EDS1,EDS2	
16	38240-VA3-900	PROTECTOR, CIRCUIT(1.0A)	1	1	EDF6,EDS1,EDS2	
17	38250-898-000	LENS ASSY., PROTECTOR	1	1	EDF6,EDS1,EDS2	
18	50319-ZB2-000	RUBBER, TANK MOUNTING	2	2	EDS1,EDS2,EDT1,ES2,VMQ3,VMT3,VS4	
19	89216-ZB4-000	WRENCH, PLUG	1	1	EDS1,EDS2,EDT1,ES2,ES3S,ES4S,VMQ3,VMT3,VS4,VS6	
20	90101-692-000	SCREW, GLOVE BOX	1	1	EDS1,EDS2,EDT1	
21	90854-ZB2-000	RUBBER, FUEL(9X15X10)	1	-	EDS1,EDS2,EDT1,ES3S,ES4S	
22	95001-45150-40 (95001-45001-60M)	TUBE, FUEL, 4.5X150	1	1	EDS1,EDS2,EDT1,ES3S,ES4S	



E-40

FUEL COCK/COMBINATION SWITCH

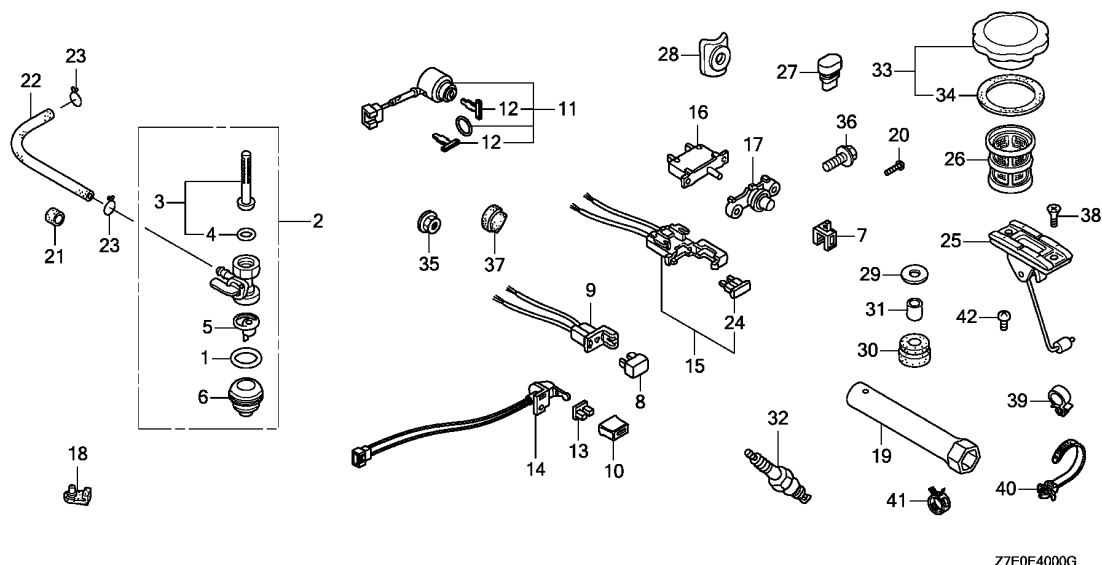

Z7E0E4000G

Ref. No.	Part No.	Description	Reqd. QTY		Serial No.	Parts catalogue code
			GX 390 H1	GX 390 H2		
23	95002-02080	CLIP, TUBE(B8)	2	2	-----	EDS1,EDS2,EDT1,ES3S,ES4S
24	98200-30500	FUSE, BLADE(5A)	1	1	-----	EDF6,EDS1,EDS2
25	17630-Z8V-003	METER ASSY., FUEL	1	1	-----	ES2,ES3S,ES4S,VMQ3,VMT3,VS4,VS6,USB4
26	17670-899-000	FILTER COMP., FUEL	1	1	-----	ES2,ES3S,ES4S,VS4,VS6,USB4
	17672-899-000	FILTER, FUEL	1	-	-----	VMQ3,VMT3
27	76122-952-000	STOPPER, DISCHARGE GUARD	4	-	-----	ES3S,ES4S,VS4,VS6
28	90501-898-000	WASHER, FRAME JOINT	8	-	-----	ES4S,VS6
29	90503-898-000	WASHER, TANK CUSHION	2	-	-----	ES2,USB4
			4	-	-----	ES3S,ES4S,VS4,VS6
			-	2	-----	ES2
30	90851-898-000	RUBBER, TANK CUSHION	2	-	-----	ES2,VMQ3,VMT3,USB4
			4	-	-----	ES3S,ES4S,VS4,VS6
			-	2	-----	ES2
31	91551-898-000	COLLAR, TANK CUSHION	2	-	-----	ES2,VMQ3,VMT3,USB4
			4	-	-----	ES3S,ES4S,VS4,VS6
			-	2	-----	ES2
32	98079-55846	PLUG, SPARK(BPR5ES)(NGK)	1	1	-----	ES2,ES3S,ES4S,VS4,VS6,USB4
	98079-56846	PLUG, SPARK(BPR6ES)(NGK)	1	1	-----	LHB5,QHB3,QHB5,SWX2
33	17620-899-800	CAP COMP., FUEL FILLER	1	1	-----	ES2,VMQ3,VMT3,VS4,VS6,USB4
	17620-899-013	1	-	-----	ES3S,ES4S
34	17631-899-000	PACKING, FUEL FILLER CAP	1	1	-----	ES2,ES3S,ES4S,VMQ3,VMT3,VS4,VS6,USB4
35	94050-08000	NUT, FLANGE, 8MM	2	2	-----	VPKK,VPXB,VPXX
			5	5	-----	VPXE,VPXJ,VPXK
36	90013-883-000	BOLT, FLANGE, 6X12(CT200)	1	-	-----	VMT3
37	90855-ZB4-000	GROMMET, CRANKCASE	1	-	-----	VMQ3,VMT3
38	93600-05010-0A	SCREW, FLAT, 5X10	2	-	-----	VMQ3,VMT3

E-40

FUEL COCK/COMBINATION SWITCH

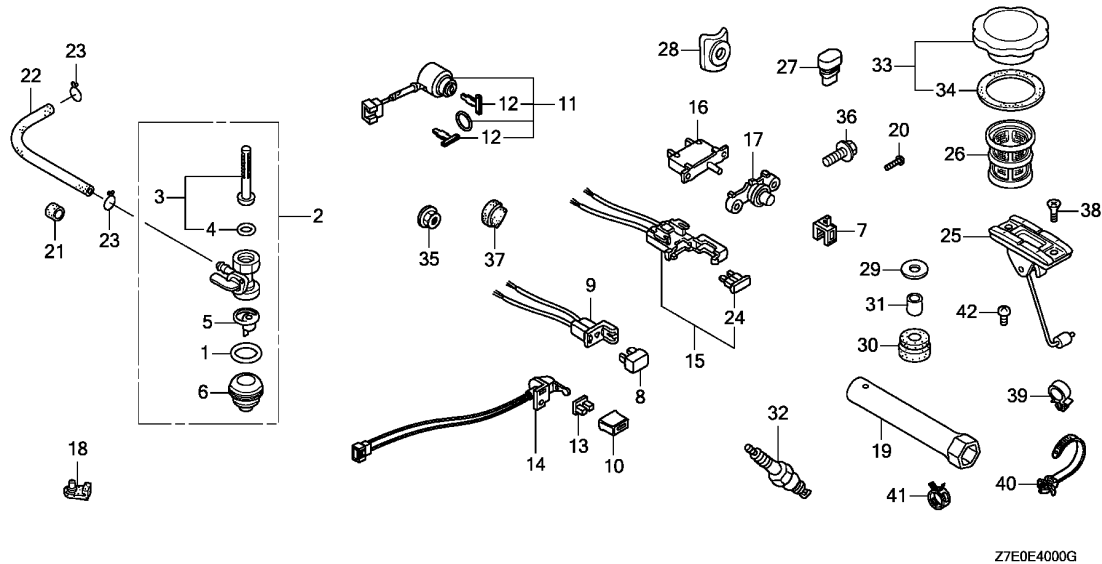

Z7E0E4000G

Ref. No.	Part No.	Description	Reqd. QTY		Serial No.	Parts catalogue code
			GX 390 H1	GX 390 H2		
39	90654-SA4-003	CLIP, WIRE HARNESS, 6MM(WHITE)	2	2	-----	VXEK,VXKS
40	90672-SAO-003	STRAP, CABLE, 118MM(BLACK) ..	1	1	-----	VPKK,VPXX,VXEK,VXKS
41	95002-40800-08	CLAMP, TUBE(D8)	1	1	-----	VPKK,VPXX
42	90050-ZE1-000	SCREW, TAPPING, 5X8	-	2	-----	VPXE,VPXK



E-40-1

MUFFLER

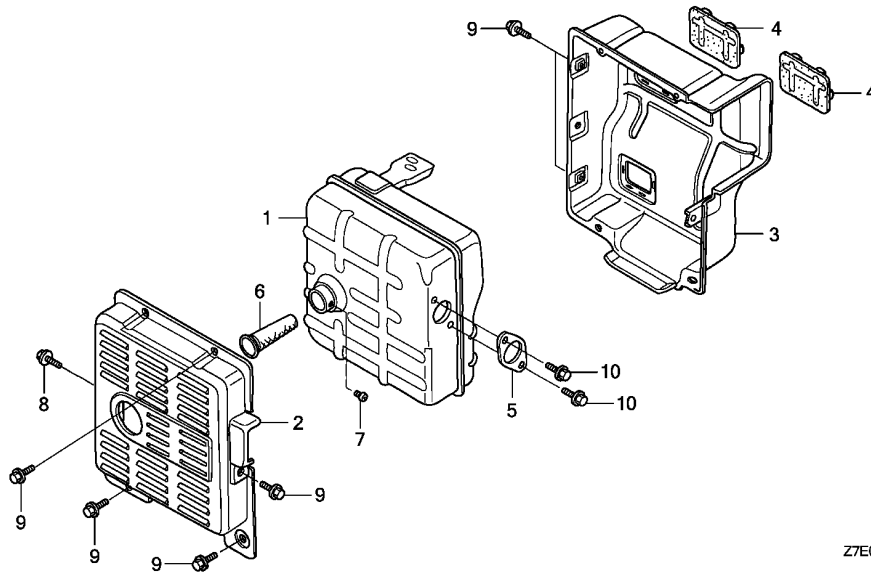

Z7E0E4001

Ref. No.	L.O.N.	(Relative ref. Number) Description	F.R.T.
1	3131C5	MUFFLER, EXHAUST	0.2
2	3131D9	PROTECTOR, EXHAUST MUFFLER : OUTER	0.1
3	3131D8	PROTECTOR, EXHAUST MUFFLER : INNER	0.2
4	3131G6	SEAL, MUFFLER PROTECTOR	0.2
5	3131B5	GASKET, EXHAUST PIPE	0.2
6	3131F9	ARRESTER, SPARK(A)	0.1
.INCLUDES: Spark arrester- inspection			

Ref. No.	Part No.	Description	Reqd. QTY		Serial No.	Parts catalogue code
			GX 390 H1	GX 390 H2		
1	18310-ZD1-E32	MUFFLER COMP. (SANKEI)	1	1	-----	EDS1,EDS2,EDT1,ES3S,ES4S
	18310-Z1C-842	MUFFLER COMP.	1	1	-----	ES2,VMQ3,VMT3,VS4
	18310-ZE2-V61	MUFFLER COMP. (TSURUMI)	1	-	-----	ES3S,ES4S
	18310-Z8W-V62	1	-	-----	VS4,VS6
2	18320-ZC2-000	PROTECTOR, MUFFLER OUTER	1	1	-----	EDS1,EDS2,EDT1,ES2,ES3S,ES4S,VMQ3,VMT3,VS4,VS6,VS4
3	18325-ZB4-000	PROTECTOR, MUFFLER INNER	1	1	-----	EDS1,EDS2,EDT1,ES2,ES3S,ES4S,VMQ3,VMT3,VS4,VS6,VS4
4	18329-ZB4-000	SEAL, MUFFLER PROTECTOR	2	2	-----	EDS1,EDS2,EDT1,ES2,ES3S,ES4S,VMQ3,VMT3,VS4,VS6,VS4
5	18333-ZB4-801	GASKET, EX. PIPE	1	-	-----	EDF6,EDS2,ES2,VMQ3,VMT3,VS4,VS6,VS4
	18333-ZB4-800	1	-	-----	EDS1,EDT1,ES3S,ES4S
	18333-Z7B-701	GASKET, EX. PIPE (NINGBO SIL GASKET)	1	-	-----	VPKK,VPX4,VPXE,VPXJ,VPXK,VPXX
	18333-ZB4-801	GASKET, EX. PIPE	-	1	-----	EDS1,EDS2,EDT1,ES2
6	18355-ZB4-630	ARRESTER, SPARK	1	1	-----	EDS1,EDS2,EDT1
7	90002-ZE2-U91	SCREW, TAPPING, 4X8	1	1	-----	EDS1,EDS2,EDT1
8	95701-06010-00	BOLT, FLANGE, 6X10	1	1	-----	EDS1,EDS2,EDT1,VMQ3,VMT3
9	95701-06012-00	BOLT, FLANGE, 6X12	7	7	-----	EDS1,EDS2,EDT1
	95701-06010-00	BOLT, FLANGE, 6X10	7	-	-----	VMQ3,VMT3
10	95701-08020-00	BOLT, FLANGE, 8X20	2	2	-----	EDF6,EDS1,EDS2,EDT1,VMQ3,VMT3

E-40-2

BATTERY TRAY

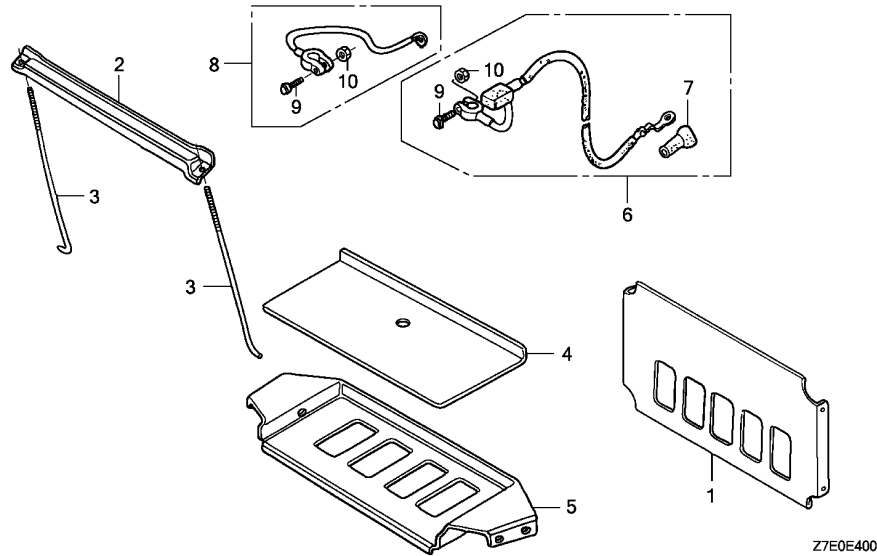

Ref. No.	L.O.N.	(Relative ref. Number) Description	F.R.T.
----------	--------	------------------------------------	--------

NO INFORMATION

Ref. No.	Part No.	Description	Reqd. QTY		Serial No.	Parts catalogue code
			GX 390 H1	GX 390 H2		
1	31511-ZB4-000	PLATE, BATTERY GUARD	1	-	----- ES4S,VS6	
2	31512-880-810	PLATE, BATTERY SETTING	1	-	----- ES4S,VS6	
3	31513-634-000	BOLT, BATTERY SETTING, 220MM	2	-	----- ES4S,VS6	
4	31521-880-000	PLATE, BATTERY	1	-	----- ES4S,VS6	
5	31550-899-000	BASE, BATTERY TRAY	1	-	----- ES4S,VS6	
6	32410-ZB4-620	CABLE ASSY., STARTING	1	-	----- ES4S,VS6	
7	32411-253-000	COVER, STARTER MOTOR TERMINAL	1	-	----- ES4S,VS6	
8	32430-ZB4-620	CABLE ASSY., EARTH	1	-	----- ES4S,VS6	
9	32601-SK7-900	BOLT, BATTERY TERMINAL	2	-	----- ES4S,VS6	
10	32602-SK7-900	NUT, BATTERY TERMINAL	2	-	----- ES4S,VS6	



E-40-3

AIR CLEANER

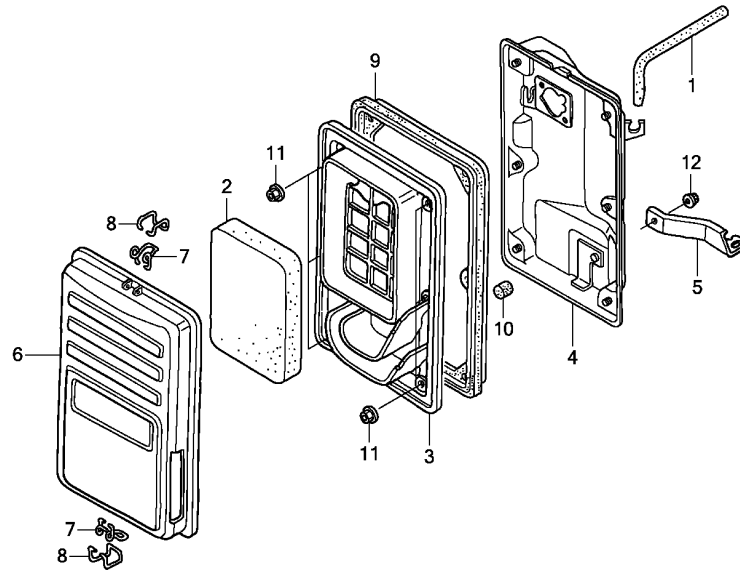

Z7E0E4003

Ref. No.	L.O.N.	(Relative ref. Number) Description	F.R.T.
1	1111K5	TUBE, BREATHER	0.1
2	3121B8	ELEMENT, AIR CLEANER	0.1
.INCLUDES: Air cleaner element -inspection			
3	3121F0	SEPARATOR, AIR CLEANER	0.1
4	3121A5	CASE, AIR CLEANER	0.2
9	3121E8	SEAL, AIR CLEANER CASE	0.1

Ref. No.	Part No.	Description	Reqd. QTY		Serial No.	Parts catalogue code
			GX 390 H1	GX 390 H2		
1	15721-ZB4-000	TUBE, BREATHER	1	-	-----	ES2,VMQ3,VMT3,VS4,VS6,USB4
2	17211-899-000	ELEMENT, AIR CLEANER	1	-	-----	ES2,VMQ3,VMT3,VS4,VS6,USB4
3	17212-ZB4-003	SEPARATOR, AIR CLEANER	1	-	-----	ES2,VMQ3,VMT3,VS4,VS6,USB4
4	17220-ZB4-003	CASE COMP., AIR CLEANER	1	-	0361369	ES2,VMQ3,VMT3,VS4,VS6,USB4
	17220-ZB4-013	1	-	0361370	ES2,VMQ3,VMT3,VS4,VS6,USB4
5	17222-ZC2-000	STAY, AIR CLEANER	1	-	-----	ES2,VMQ3,VMT3,VS4,VS6,USB4
6	17231-899-000	COVER COMP., AIR CLEANER	1	-	-----	ES2,VMQ3,VMT3,VS4,VS6,USB4
7	17235-899-000	CLIP A, AIR CLEANER WIRE	2	-	-----	ES2,VMQ3,VMT3,VS4,VS6,USB4
8	17236-899-000	CLIP B, AIR CLEANER WIRE	2	-	-----	ES2,VMQ3,VMT3,VS4,VS6,USB4
9	17252-899-000	SEAL, AIR CLEANER	1	-	-----	ES2,VMQ3,VMT3,VS4,VS6,USB4
10	17367-413-690	FILTER, DRAIN TUBE	1	-	-----	ES2,VMQ3,VMT3,VS4,VS6,USB4
11	94050-05000	NUT, FLANGE, 5MM	6	-	-----	ES2,VMQ3,VMT3,VS4,VS6,USB4
12	94050-06000	NUT, FLANGE, 6MM	1	-	-----	VMQ3,VMT3

E-40-4

MARK

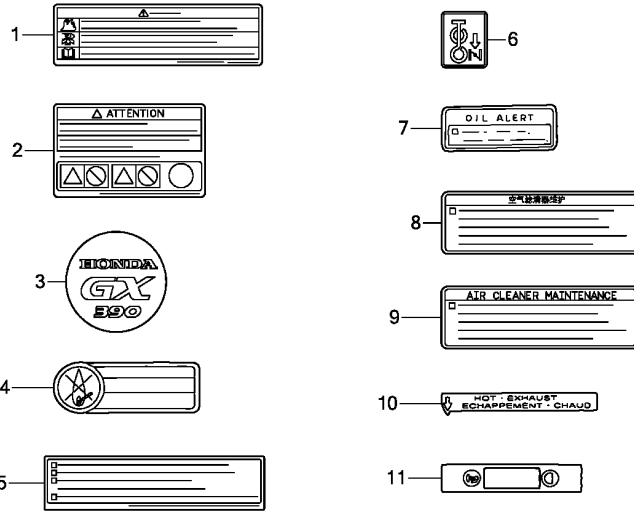

Z7E0E4004

Ref. L.O.N. (Relative ref. Number) F.R.T.
No. Description

NO INFORMATION

Ref. No.	Part No.	Description	Reqd. QTY		Serial No.	Parts catalogue code	
			GX 390 H1	GX 390 H2			
1	87516-Z1T-800	MARK, OPERATOR CAUTION(KOREAN)	1	-	-----	VS4,VS6,VS4	
	87516-ZK6-810	MARK, OPERATOR CAUTION (CHINESE)(MADE IN CHINA)	1	-	-----	VSP	
2	87516-ZH7-800	MARK, OPERATOR CAUTION(FRENCH)(MADE IN JAPAN)	1	-	-----	0053888 VPX4	
	87516-Z4N-800	MARK, OPERATOR CAUTION(FRENCH)(MADE IN CHINA)	1	-	0053889	-----	VSP
3	87521-ZF6-W04	EMBLEM(HONDA GX390)	1	1	-----	ES2,ES3S,ES4S,VS4,VS6,VS4	
4	87522-883-660	MARK, CAUTION (ENGLISH/FRENCH/SPANISH)	1	1	-----	EDF6,EDS1,EDS2,EDT1	
5	87522-Z1T-G21	LABEL, CAUTION	1	1	-----	VTE5	
6	87528-898-620	MARK, CHOKE	1	1	-----	EDF6,EDS1,EDS2,EDT1,ES2,ES3S,ES4S,VMQ3,VMT3,VPKK,VPX4,VPXB,VPXE,VPXJ,VPXK,VPXX,VS4,VS6,VS4,VXEK,VXKS	
7	87532-ZH8-810	MARK, OIL ALERT(ENGLISH)	1	1	-----	VTE5	
8	87533-Z7E-800	MARK, AIR CLEANER(CHINESE) ..	1	-	-----	EDS2,VPXB,VPXE,VPXJ,VPXK	
			1	-	0010335	-----	EDS1,EDT1,VPX4
			-	1	-----	EDS1,EDS2,EDT1,VPXB,VPXE,VPXK	
9	87533-ZC0-630	MARK, AIR CLEANER(ENGLISH) ..	1	1	-----	EDF6,ES2,ES3S,ES4S,VMQ3,VMT3,VPKK,VPXX,VS4,VS6,VS4,VXEK,VXKS	
			(1)	(1)	-----	VPKK,VPX4,VPXB,VPXE,VPXJ,VPXK,VPXX,VXEK,VXKS	
			1	-	0010334	-----	EDS1,EDT1
10	87539-898-620	MARK, EX. CAUTION (ENGLISH/FRENCH)	1	1	-----	EDF6,EDS1,EDS2,EDT1,ES2,ES3S,ES4S,VMQ3,VMT3,VS4,VS6,VS4	
11	87565-ZB4-A00	PLATE, FUEL INDICATION	1	-	-----	VMQ3,VMT3	



EOP-2

MUFFLER COVER

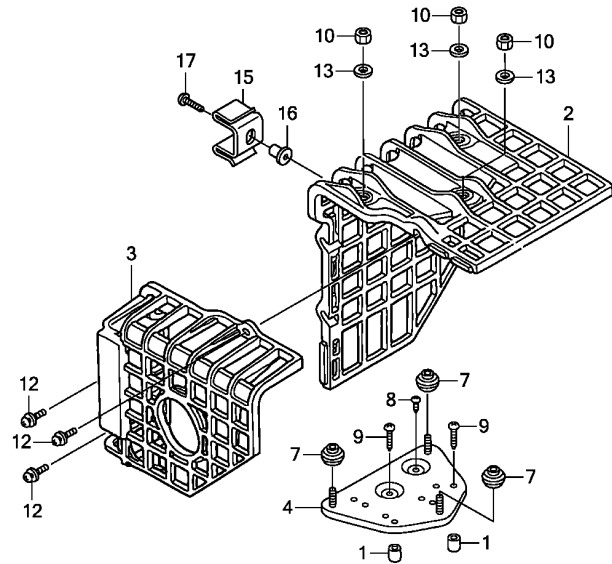

Ref. L.O.N. (Relative ref. Number) F.R.T.
No. Description

NO INFORMATION

Ref. No.	Part No.	Description	Reqd. QTY		Serial No.	Parts catalogue code
			GX 390 H1	GX 390 H2		
1	17233-896-701	COLLAR, AIR CLEANER CASE	(2)	-	-----	QHB1,VPKK,VPX4,VPXB,VPXE,VPXJ,VPXK,VPXX,VXEK,VXKS
2	18433-Z5T-000	COVER COMP., MUFFLER	(1)	-	-----	QHB1,VPKK,VPX4,VPXB,VPXE,VPXJ,VPXK,VPXX,VXEK,VXKS
3	18434-Z5T-000	COVER COMP., RR. MUFFLER	(1)	-	-----	QHB1,VPKK,VPX4,VPXB,VPXE,VPXJ,VPXK,VPXX,VXEK,VXKS
4	18436-ZH8-W41	BASE COMP., MUFFLER COVER	(1)	-	-----	QHB1,VPKK,VPX4,VPXB,VPXE,VPXJ,VPXK,VPXX,VXEK,VXKS
7	18466-ZH8-W40	SPACER, MUFFLER COVER	(3)	-	-----	QHB1,VPKK,VPX4,VPXB,VPXE,VPXJ,VPXK,VPXX,VXEK,VXKS
8	90050-ZE1-000	SCREW, TAPPING, 5X8	(1)	-	-----	QHB1,VPKK,VPX4,VPXB,VPXE,VPXJ,VPXK,VPXX,VXEK,VXKS
9	90050-ZH8-W40	SCREW, TAPPING, 5X25	(2)	-	-----	QHB1,VPKK,VPX4,VPXB,VPXE,VPXJ,VPXK,VPXX,VXEK,VXKS
10	90302-KF9-900	NUT, HEX., 5MM	(3)	-	-----	QHB1,VPKK,VPX4,VPXB,VPXE,VPXJ,VPXK,VPXX,VXEK,VXKS
12	93891-06020-07	SCREW-WASHER, 6X20	(3)	-	-----	QHB1,VPKK,VPX4,VPXB,VPXE,VPXJ,VPXK,VPXX,VXEK,VXKS
13	94103-05700	WASHER, PLAIN, 5MM	(3)	-	-----	QHB1,VPKK,VPX4,VPXB,VPXE,VPXJ,VPXK,VPXX,VXEK,VXKS
15	18437-Z5T-000	STAY, MUFFLER COVER	(1)	(1)	-----	ES2,QHB1,VPKK,VPX4,VPXB,VPXE,VPXJ,VPXK,VPXX,VS B4,VXEK,VXKS
16	19619-ZL8-300	COLLAR, FAN COVER	(1)	(1)	-----	ES2,QHB1,VPKK,VPX4,VPXB,VPXE,VPXJ,VPXK,VPXX,VS B4,VXEK,VXKS
17	90006-Z5T-000	SCREW, TAPPING, 6X25	(1)	(1)	-----	ES2,QHB1,VPKK,VPX4,VPXB,VPXE,VPXJ,VPXK,VPXX,VS B4,VXEK,VXKS

PART NO. INDEX

Part Number	Page Ref.	Part Number	Page Ref.	Part Number	Page Ref.	Part Number	Page Ref.	Part Number	Page Ref.	Part Number	Page Ref.
06000		12391-ZE2-020	29 7			15000		16100-Z7E-801	60 9	16265-Z7E-000	65 21
06160-Z7F-305	67 50			13104-Z7E-930	44 2			16100-Z7E-811	61 9	16265-ZE2-721	66 21
06160-Z7F-315	67 50	13000		13104-ZF6-W00	43 2	15600-735-003	35 4	16100-Z7E-821	61 9	16268-893-000	91 1
06280-Z7E-305	52 20	13010-Z5R-004	41 1	13104-ZF6-W01	44 2	15600-Z0T-820	35 3	16100-Z7E-931	61 9	16268-ZE2-721	66 22
			43 1	13111-Z5T-000	44 3	15600-Z1C-000	35 4	16100-Z7E-941	65 8	16271-ZE2-010	68 1
11000		13010-Z5T-003	41 1	13111-Z7E-000	44 3	15600-Z1T-600	34 3	16100-Z7E-951	65 8		
			43 1	13111-ZF6-W00	44 3		35 3	16100-Z7E-961	64 8	16400-ZE2-704	66 24
11300-Z1C-600	34 1	13010-Z7E-701	42 1	13200-Z1C-000	45 4		38 3	16100-Z7E-D11	64 8	16500-Z5T-000	90 31
11300-Z7E-000	34 1	13010-Z7E-931	43 1	13200-Z1C-305	44 4	15600-Z7E-000	35 4	16100-Z7E-D21	64 8	16500-Z5T-800	89 6
11300-Z7E-700	39 1	13010-ZF6-003	42 1		45 4		38 4	16100-Z7E-W31	60 9	16500-Z5T-810	89 5
11300-Z7E-800	34 1	13010-ZF6-005	43 1	13200-Z7E-000	44 4	15600-ZG4-003	35 3	16100-Z7F-814	64 8	16500-Z5T-870	89 24
11300-Z7E-810	38 1	13011-Z5R-004	41 1		45 4	15620-Z7E-800	39 4	16100-ZF6-743	64 8	16500-Z5T-880	90 29
11300-Z7E-P70	34 1		43 1	13200-Z7E-305	45 4	15625-Z0T-800	35 5	16100-ZF6-V41	64 8	16500-Z5T-890	90 29
11300-ZE3-040	34 1	13011-Z5T-003	41 1	13200-ZE3-020	45 4		38 5	16100-ZF6-V42	64 8	16510-Z7E-000	35 7
11300-ZE3-604	34 1		43 1	13200-ZE3-315	45 4	15625-Z1T-000	35 6	16124-ZE0-005	61 10		38 7
11300-ZE3-P70	34 1	13011-Z7E-701	42 1	13310-Z7E-000	40 1		38 6		65 9		39 5
11315-ZE3-700	39 2	13011-Z7E-931	43 1	13310-Z7E-700	40 10		38 6	16141-Z0S-003	63 30	16510-ZE3-000	35 7
11381-Z5T-000	34 2	13011-ZF6-003	43 1	13310-Z7E-800	40 2	15625-ZE1-003	35 5	16148-141-881	65 10	16511-ZE8-000	35 8
	38 2	13011-ZF6-005	43 1	13310-Z7E-810	40 3		6	16166-Z5T-901	61 11		38 8
	39 3	13012-Z5R-004	41 1	13310-Z7E-820	40 4	15721-Z23-H60	30 19	16166-Z7E-941	65 11		39 6
11381-Z7E-701	34 2		43 1	13310-Z7E-830	40 11	15721-ZB4-000	30 19	16166-Z7E-951	65 11	16512-Z7E-000	35 9
	38 2	13012-Z5T-003	42 1	13310-ZF6-W42	40 3		104 1	16166-Z7E-951	65 11		36 9
	39 3		43 1	13351-Z7E-000	40 5			16166-ZF6-005	61 11		38 9
11381-ZE3-801	34 2	13012-Z7E-701	42 1	13351-ZE3-010	40 5	16000		16166-ZF6-V00	61 11		39 7
	38 2	13012-Z7E-931	43 1			16010-Z7E-971	59 1	16166-ZF6-W20	61 11	16512-ZE3-000	36 9
	39 3	13012-ZF6-003	43 1	14000		16010-ZA0-921	64 1	16172-ZE3-W10	61 12	16513-ZE2-000	36 10
11500-Z7E-020	94 1	13012-ZF6-005	43 1	14100-Z7E-930	46 2	16010-ZE2-015	63 28	16173-001-004	61 13		38 10
11521-Z7B-701	94 2	13013-Z5R-004	41 1	14100-ZF6-W01	46 2	16010-ZE2-812	59 1		99 1		39 8
11521-ZE2-800	94 2		43 1	14410-Z1C-000	46 3	16010-ZE3-701	64 1	16211-Z5T-000	61 14	16531-Z0A-000	36 11
		13013-Z5T-003	42 1	14410-Z7E-000	46 3	16011-Z7E-701	63 29	16211-Z7E-000	61 14		38 11
			43 1	14410-ZE3-013	46 3	16011-ZA0-931	59 2	16211-Z7E-700	65 13		39 9
12000		13013-Z7E-701	42 1	14431-ZE2-010	46 4		64 2	16211-ZBH-700	65 13	16541-Z7E-000	31 2
12000-Z5T-405	31 1	13013-Z7E-931	43 1	14441-Z7E-000	46 5	16013-Z1C-003	59 3	16211-ZF6-000	61 14	16541-ZE3-010	31 2
12000-Z5T-406	31 1	13013-ZF6-003	43 1		47 5		64 3	16211-ZF6-D40	65 13	16550-ZE3-700	90 28
12000-Z5T-407	31 1	13013-ZF6-005	43 1	14441-ZE2-000	46 5	16013-Z7E-701	59 3	16212-Z5T-000	61 17	16551-ZE3-000	88 1
12000-Z5T-408	31 1	13101-Z5T-000	43 2	14451-Z7E-000	47 6	16013-ZA0-931	64 3		65 15	16555-ZE3-000	88 2
12000-Z7E-405	31 1	13101-Z7E-800	43 2	14568-ZE1-000	47 7	16015-Z7B-D11	64 4	16212-Z7E-701	61 17	16561-ZE3-000	88 3
12000-Z7E-406	31 1		44 2	14711-Z5T-900	47 8	16015-Z7E-971	60 4		65 15	16561-ZE3-710	88 3
12000-Z7E-407	31 1	13101-Z7E-930	44 2	14711-Z7E-000	47 8	16015-ZA0-931	64 4	16220-ZA0-702	61 15	16561-ZF6-T21	88 3
12000-Z7E-408	31 1	13101-ZF6-W00	43 2	14711-ZE3-000	47 8	16015-ZE8-005	59 4		67 51	16561-ZF6-W32	88 3
12200-Z1C-406	28 1	13101-ZF6-W01	43 2	14721-Z5T-800	47 9	16016-Z1E-V21	60 5	16221-Z5T-000	61 16	16561-ZK6-D70	88 3
12200-Z7E-000	28 1		44 2	14721-Z5T-900	47 9		64 5		65 14	16562-ZE2-700	88 4
12200-ZF6-406	28 1	13102-Z5T-000	43 2	14721-Z7E-000	47 9	16016-ZF6-005	60 5	16221-Z7E-701	61 16	16562-ZE3-000	88 4
12204-Z7E-305	28 2	13102-Z7E-800	43 2	14721-Z7E-800	47 9	16016-ZF6-D40	67 48		65 14	16562-ZE3-700	88 4
12204-ZE2-306	28 2		44 2	14721-ZE3-000	47 9	16016-ZH7-W01	60 5	16221-ZF6-800	61 16	16570-ZE3-700	90 29
12205-Z7E-305	28 3	13102-Z7E-930	44 2	14721-ZE3-810	47 9	16016-ZH8-W01	64 5		65 14	16570-ZE3-710	90 29
12205-ZE2-305	28 3	13102-ZF6-W00	43 2	14751-Z1C-000	48 10	16024-124-760	64 6	16223-ZE3-W00	61 17	16570-ZE3-721	89 24
12209-Z7E-003	46 1	13102-ZF6-W01	43 2	14751-Z7E-000	48 10	16024-124-761	64 6		65 15	16570-ZE3-W00	90 31
12209-ZE8-003	46 1		44 2	14751-ZE2-003	48 10	16024-Z5T-901	60 6	16230-ZE3-702	67 45	16570-ZE3-W10	89 6
12210-Z7E-405	28 1	13103-Z5T-000	43 2	14771-ZE2-000	48 11	16024-ZE1-811	60 6	16260-Z7E-000	65 16	16570-ZE3-W20	88 5
12216-ZE2-300	28 4	13103-Z7E-800	43 2		48 12	16028-Z1T-WA1	60 7	16260-Z7E-800	65 16	16571-ZE3-W00	89 7
12251-Z1C-801	29 5		44 2	14773-ZE2-000	48 12	16028-Z7E-E61	64 7	16260-ZE2-723	65 16	16574-ZE1-000	89 8
12251-Z5T-003	29 5	13103-Z7E-930	44 2	14775-ZE2-010	48 13	16028-ZA0-931	64 7	16260-ZE3-D22	65 16	16575-ZE2-W00	89 9
12251-ZF6-W00	28 5	13103-ZF6-W00	43 2	14781-Z7E-000	48 14	16028-ZE0-005	60 7	16261-ZE2-702	65 17	16576-891-000	89 10
	29 5	13103-ZF6-W01	43 2	14781-ZE2-000	48 14	16044-Z5T-901	60 8	16262-ZE2-711	65 18	16578-ZE1-000	89 11
	28 5		44 2	14791-Z7E-000	48 15	16044-ZE3-W20	60 8	16263-Z7B-000	65 19	16580-Z5T-000	89 12
12251-ZF6-W01	28 5	13104-Z5T-000	43 2		49 15	16100-Z1C-V51	61 9	16263-ZA0-000	65 19	16581-ZE3-W00	89 12
12310-ZE2-020	29 6		43 2	14791-ZE2-010	48 15	16100-Z7E-701	61 9	16264-ZE2-701	65 20	16584-883-300	89 13
12357-Z5T-020	29 13	13104-Z7E-800	43 2								



PART NO. INDEX

Part Number	Page	Ref.	Part Number	Page	Ref.	Part Number	Page	Ref.	Part Number	Page	Ref.	Part Number	Page	Ref.
35000			87000			88000			90101-692-000	99	20	93892-05012-18	67	47
35100-Z5T-811	93	11	87114-ZH7-000	95	1	88911-MJ3-000	66	30	90107-959-003	94	6	93892-05032-18	85	18
35100-ZB4-023	99	11	87114-ZH7-840	95	1				90110-ZE2-003	84	15			
35100-ZE2-033	93	11	87516-Z1T-800	95	3	89000			90114-SAO-000	89	18	94000		
35111-880-013	93	12		105	1				90131-883-000	32	6	94001-04390-0S	93	23
	99	12	87516-Z1V-800	96	7	89216-ZB4-000	99	19	90201-Z1T-601	69	11	94050-05000	70	10
35120-Z0D-V81	57	4				89218-ZE1-000	98	1	90201-ZE3-V00	79	6	91001-Z7B-003	94	13
35120-Z0T-801	57	4				89219-805-000	98	2	90202-Z1T-000	89	18	91001-Z7E-003	37	18
35120-Z0T-851	58	7	87516-Z4N-000	96	7				90202-Z2E-000	73	10		38	19
35120-Z7E-931	58	10	87516-Z4N-800	105	2	90000			90203-ZA0-800	69	13	94050-06000	67	49
35480-Z7E-003	32	4	87516-Z4N-810	96	7				90206-ZE1-000	49	17	91001-ZF6-013	40	8
35480-ZF6-003	32	4	87516-ZCL-800	96	7	90001-Z7E-000	45	5	90302-KF9-900	106	10	91002-Z7E-003	40	8
35850-Z7E-701	87	16				90001-ZE8-000	45	5	90325-044-000	69	11	91009-KJ1-003	38	14
35851-Z7E-701	87	17	87516-ZH7-000	96	7	90002-ZE2-U91	102	7		72	9		94	9
35852-Z7E-701	87	18	87516-ZH7-800	105	2	90003-ZH8-801	51	12	90380-MA6-010	73	11	91201-Z1C-003	32	8
35853-Z7E-701	87	19	87516-ZH7-810	96	7				90431-ZE2-700	66	31	91201-Z7B-003	94	10
35854-Z7E-701	87	20	87516-ZK6-810	95	3	90004-Z5T-000	58	11	90432-ZE2-700	66	32	91201-Z7E-003	32	8
				96	7	90004-ZE2-W01	53	11	90433-ZE2-700	67	33		33	8
				17		90005-ZM3-000	71	20	90434-ZE2-700	67	34		37	14
36000				105	1	90006-Z5T-000	106	17	90441-ZE2-010	29	10	94050-10000	33	11
36100-ZF6-P82	58	7	87519-Z4N-000	96	7	90006-ZE2-000	75	8	90446-KE1-000	32	7	94070-06080	85	19
36101-ZE2-701	81	6		97	22	90007-ZE2-003	84	17	90446-Z7E-000	32	7	94101-04800	93	24
36101-ZE3-800	81	6	87521-ZF6-W04	95	2	90008-Z1T-000	51	13	90473-ZE3-010	94	7	94101-06800	37	15
36103-V42-000	81	7		105	3				90501-898-000	100	28		33	9
36103-ZE1-000	81	7	87522-883-660	105	4				90503-898-000	100	29	91203-952-771	33	9
36106-892-003	99	13	87522-Z1T-G21	95	3	90008-ZE2-003	53	12	90534-706-010	40	6	91203-Z7E-003	33	9
36110-ZB4-702	99	14		97	23	90009-Z1C-000	69	10	90601-27E-000	67	37	91301-805-000	39	14
36135-ZF6-D41	66	28							90601-ZE3-000	45	6	91353-671-004	33	10
36160-ZB4-013	91	3		105	5				90602-Z7E-000	67	38		77	9
			87522-Z1T-J00	95	4	90009-ZE2-003	69	10	90602-ZE1-000	36	12	91406-166-000	33	19
			87522-ZH9-010	95	3	90012-888-000	81	9		38	12	91406-ZE2-003	93	20
			87524-Z0S-801	96	19				90603-Z7E-000	67	39	91424-Z4K-801	77	16
38220-ZE1-000	99	15	87524-Z0T-800	96	19	90012-ZE0-010	49	16	90605-230-000	89	19	91424-Z4K-802	77	16
38240-VA3-900	93	13	87528-898-620	105	6	90013-883-000	32	5	90605-Z1T-000	89	19	91424-Z5L-802	77	11
	99	16	87528-Z7E-000	95	5				90630-751-000	82	18	91551-898-000	100	31
38250-898-000	99	17		97	20					93	18	91601-ZE2-003	84	16
38250-ZA8-701	93	14	87528-ZH7-000	95	5				90650-SD9-003	67	46			
				96	20				90654-SA4-003	58	9	92000		
			87529-Z4T-840	93	15					101	39	95001-45150-40	99	22
			87529-ZE2-812	93	15				90672-SAO-003	93	19	95001-45165-40	77	18
50319-ZB2-000	99	18	87532-Z7E-000	96	6	90014-ZE2-000	29	8		101	40	95001-45235-40	77	11
			87532-Z7E-010	95	6	90014-ZE6-000	81	9	90684-Z7E-000	81	11	95002-02070	67	40
				96	6	90015-883-000	81	10	90684-ZA0-601	81	11	95002-02080	77	12
53000				18		90015-ZE5-010	89	17	90701-HC4-000	36	13			
53149-964-003	66	29		97	26	90016-ZG9-N30	89	26	90701-Z7E-000	36	13	93000		
			87532-ZH7-000	97	21	90017-883-000	81	9		38	13	93500-03006-1H	62	24
			87532-ZH8-810	95	6	90019-883-000	39	10		39	12	93500-03012-OH	93	21
				96	18	90042-ZE3-700	29	9	90741-805-000	40	7	93500-04006-OH	89	20
68325-899-000	33	18		97	26	90042-ZE8-000	29	9		94	8	93500-04012-OH	93	22
68325-ZC2-000	33	17		105	7	90042-ZK6-D70	29	9	90741-889-810	40	7	93500-05008-OA	91	5
			87532-ZK7-800	95	6	90050-ZE1-000	75	10		94	8	93500-05012-OA	67	35
			87533-Z7E-800	105	8				90741-ZE2-000	79	7	93500-05016-OA	89	21
			87533-ZC0-630	105	9				90745-ZE2-600	40	7	93500-05032-OA	89	22
76000			87539-898-620	105	10				90745-ZK2-800	94	8	93500-05035-OA	90	30
76122-952-000	100	27	87565-ZB4-A00	105	11				90802-Z6L-000	71	21	93500-05045-OA	90	27
			87594-ZB4-A00	96	13	90050-ZH8-W40	106	9	90851-898-000	100	30	93600-05010-OA	100	38
						90055-ZE1-000	75	11	90854-ZB2-000	77	19	93891-06020-07	106	12
81000														
81329-567-020	58	5												



PART NO. INDEX

Part Number	Page	Ref.	Part Number	Page	Ref.	Part Number	Page	Ref.	Part Number	Page	Ref.	Part Number	Page	Ref.
95701-06032-08	71	22												
95701-08020-00	102	10	99101-ZH8-1080	67	43									
95701-08025-00	77	13	99204-ZA0-0400	63	27									
95701-08035-08	85	20	99204-ZA0-0450	63	27									
	87	21		67	44									
95701-08040-00	37	16	99204-ZE0-0380	63	27									
	38	16	99204-ZE0-0450	67	44									
	39	16												
	94	12												
95701-10080-00	29	14												
95725-10080-00	29	14												
96000														
96100-62020-00	33	15												
	37	17												
	38	17												
	39	17												
96100-62040-00	38	18												
96100-62060-00	94	13												
96100-62070-00	37	18												
	38	19												
	39	18												
98000														
98079-55846	29	15												
	100	32												
98079-55855	29	15												
98079-55876	29	15												
98079-56846	29	15												
	100	32												
98079-56855	29	15												
98200-30500	93	26												
	100	24												
99000														
99001-10120	98	3												
99001-14170	98	4												
99004-21002	98	1												
99101-ZDK-0920	67	43												
99101-ZDK-0980	67	43												
99101-ZDK-1000	63	26												
	67	43												
99101-ZDK-1050	63	26												
	67	43												
99101-ZDK-1080	63	26												
	67	43												
99101-ZH8-0880	63	26												
99101-ZH8-0900	62	26												
99101-ZH8-0920	63	26												
99101-ZH8-0950	63	26												
99101-ZH8-0980	67	43												
99101-ZH8-1000	63	26												
	67	43												
99101-ZH8-1020	63	26												
	67	43												
99101-ZH8-1050	63	26												

PART NAME INDEX

Part name	Page	Ref.	Part name	Page	Ref.	Part name	Page	Ref.
[A]				91	4	CARBURETOR ASSY.	60	9
ALERT UNIT, OIL	31	3		93	16		61	9
	92	10		100	36		64	8
ARMATURE ASSY.	86	3	BOLT, FLANGE, 6X28	81	10	CASE COMP., AIR CLEANER	70	3
ARMATURE COMP.	83	2	BOLT, FLANGE, 6X32	71	22		71	12
ARM COMP., GOVERNOR	90	28		81	9		104	4
ARM, GOVERNOR	88	1	BOLT, FLANGE, 6X35	81	9	CASE COMP., FUSE	99	15
ARM, VALVE ROCKER	46	4	BOLT, FLANGE, 6X40	81	9	CASE COMP., RECOIL STARTER	50	2
ARRESTER COMP., SPARK	75	17		82	15		53	2
ARRESTER, SPARK	75	14	BOLT, FLANGE, 8X20	102	10		54	2
		18	BOLT, FLANGE, 8X25	77	13	CASE, CONTROL	92	3
	102	6		94	6	CHAMBER SET, FLOAT	59	4
[B]			BOLT, FLANGE, 8X35	85	20		60	4
BAND	92	9		87	21		64	4
BARREL ASSY., CYLINDER	31	1	BOLT, FLANGE, 8X40	37	16	CHOKE SET	60	8
BASE COMP., AIR CLEANER	71	14		38	16	CIRCLIP, 5MM	89	19
BASE COMP., CONTROL	89	12	BOLT, GOVERNOR ARM	89	17	CLAMPER, CORD	81	3
BASE COMP., MUFFLER COVER	106	4	BOLT, HEAD COVER	29	8	CLAMP, TUBE	77	17
BASE, BATTERY TRAY	103	5	BOLT, HEX., 8X25	40	9			21
BEARING, BALL RADIAL, 6207SH2	40	8	BOLT, PIVOT, 8MM	49	16	CLIP A, AIR CLEANER WIRE	70	6
BEARING, RADIAL BALL, 6202 ...	33	15	BOLT, STUD, 8X106	29	9		104	7
	37	17	BOLT, STUD, 8X115	29	9	CLIP B, AIR CLEANER WIRE	70	7
	38	14	BOLT, STUD, 8X131.5	29	9		104	8
		17	BOLT, STUD, 8X22	29	11	CLIP, GOVERNOR HOLDER	36	12
	39	17	BOLT, STUD, 8X32	29	11		38	12
BEARING, RADIAL BALL, 6204 ...	94	9	BOX ASSY., CONTROL	92	1		39	11
BEARING, RADIAL BALL, 6206 ...	38	18			2	CLIP, HARNESS	81	11
BEARING, RADIAL BALL, 6207 ...	94	13	BRACKET ASSY.	87	14	CLIP, PISTON PIN, 20MM	45	6
	37	18	BRACKET, CASE MOUNTING	92	4	CLIP, PURSE LOCK	82	18
	38	19	BRACKET, CENTER	83	5		93	18
	39	18	BRACKET, FR.	83	6	CLIP, TUBE	57	1
BEARING, RADIAL BALL, 6207SH .	40	8	BRUSH	83	8		67	40
BOARD ASSY., BRUSH	86	6	BUSH, ARM PIVOT	66	29		77	12
BOLT-WASHER, 5X14	84	17	BUSH, CONTROL KNOB	99	13			20
BOLT-WASHER, 6X22	69	10						22
	72	8	[C]				100	23
	73	9	CABLE ASSY., EARTH	103	8	CLIP, VALVE GUIDE	28	4
BOLT KIT, FUEL CHAMBER	67	50	CABLE ASSY., STARTER	87	15	CLIP, WIRE	33	19
BOLT, BATTERY SETTING, 220MM .	103	3	CABLE ASSY., STARTING	103	6		99	7
BOLT, BATTERY TERMINAL	103	9	CAMSHAFT ASSY.	46	2	CLIP, WIRE HARNESS	67	46
BOLT, CONNECTING ROD	45	5	CAP ASSY., NOISE SUPPRESSOR ...	80	2		58	9
BOLT, DRAIN PLUG, 12X15	32	6		81	2		101	39
BOLT, FLANGE, 10X80	29	14	CAP ASSY., OIL FILLER	34	3	CLUTCH COMP., OVERRUNNING	83	3
BOLT, FLANGE, 5X10	39	10		35	3	COCK ASSY., FUEL	99	2
BOLT, FLANGE, 5X18	71	20			4	COIL ASSY., CHARGE	81	5
BOLT, FLANGE, 6X10	51	13			3	COIL ASSY., IGNITION	80	1
	53	12			4		81	12
	56	13		38	3		82	12
	102	8			4		16	
		9	CAP COMP., AIR CLEANER	72	7	COIL ASSY., LAMP	82	13
BOLT, FLANGE, 6X12	32	5	CAP COMP., FUEL FILLER	76	4			14
	33	14		100	33	COLLAR B, AIR CLEANER	69	8
	58	6	CAP, CHOKE DUST	65	10		72	4
	75	9	CAP, MUFFLER	74	5		73	6
	81	8	CAP, OIL FILLER	39	4	COLLAR, AIR CLEANER	68	7
	89	16	CAP, SEALING	71	21		69	7
							71	18

PART NAME INDEX

Part name	Page	Ref.	Part name	Page	Ref.	Part name	Page	Ref.
		19	[E]			GOVERNOR ASSY.	35	7
	72	3					38	7
	73	5	ELBOW COMP., AIR CLEANER	69	9		39	5
COLLAR, AIR CLEANER CASE	106	1		72	6	GRIP, STARTER	51	10
COLLAR, FAN COVER	106	16		73	7		53	9
COLLAR, LEVER	67	34	ELEMENT COMP., AIR CLEANER	68	2		55	10
COLLAR, SETTING	61	12		73	1	GROMMET, AIR CLEANER	68	5
	65	12	ELEMENT, AIR CLEANER	68	2		73	3
COLLAR, STOPPER	89	25		70	1	GROMMET, CHOKE ROD	66	26
COLLAR, TANK CUSHION	100	31		104	2	GROMMET, CORD	81	4
CONE ASSY., NOSE	86	5	EMBLEM	95	2	GROMMET, CRANKCASE	100	37
CONTACTOR ASSY.	83	1		105	3	GROMMET, DRAIN HOLE	58	5
CONTROL ASSY.	88	5	E-RING, 2MM	67	37	GROMMET, FENDER	66	30
	89	5	E-RING, 4MM	67	38	GUIDE, CHOKE ROD	66	27
		6	E-RING, 7MM	67	39	GUIDE, EX. VALVE	28	3
		24				GUIDE, IN. VALVE	28	2
	90	29	[F]			GUIDE, PUSH ROD	48	15
		31					49	15
CORD, EARTH	33	16	FAN, COOLING	78	1	GUIDE, RATCHET	51	6
CORD, STOP SWITCH	81	6	FILTER COMP., FUEL	100	26		55	6
COUNTERSHAFT COMP.	94	4	FILTER, CUP	99	5			
COUPLER COMP.	99	9	FILTER, DRAIN TUBE	70	9	[H]		
COVER ASSY., CRANKCASE	34	1		104	10	HANDLE, BOX WRENCH	98	2
	38	1	FILTER, FUEL	76	6	HARNES ASSY., ENGINE WIRE	82	17
	39	1		100	26	HARNES, SUB WIRE	92	8
COVER ASSY., GEAR CASE	94	1	FILTER, OUTER	68	3	HEAD COMP., CYLINDER	28	1
COVER COMP., AIR CLEANER	70	5	FLANGE COMP., BAFFLE	75	21	HOLDER, BRUSH	84	12
	72	2	FLOAT SET	59	3	HOLDER, CABLE	89	10
	104	6		64	3	HOLDER, FUEL FILTER	76	8
COVER COMP., FAN	57	2	FLYWHEEL COMP.	78	4	HOLDER, GOVERNOR WEIGHT	35	9
COVER COMP., HEAD	29	6		79	4		36	9
COVER COMP., MUFFLER	106	2			5		38	9
COVER COMP., RR. MUFFLER	106	3	FUSE, BLADE	93	26		39	7
COVER, AIR CLEANER	68	4		100	24	HOLDER, STOP SWITCH CORD	81	7
	71	16	[G]			HOLDER, WIRE	89	15
	73	2				HOUSING ASSY.	86	2
COVER, DUCT	39	2	GASKET SET	59	1			
COVER, STARTER MOTOR TERMINAL	103	7		63	28	[I]		
CRANKSHAFT COMP.	40	1	GASKET, CYLINDER HEAD	64	1	INSULATOR	84	14
		2		28	5	INSULATOR, CARBURETOR	61	14
		3	GASKET, EX. PIPE	29	5		65	13
		4		30	17			
		10	GASKET, MUFFLER	74	6	[J]		
		11		75	13	JET SET, PILOT, #38	63	27
CUP, FUEL STRAINER	62	23		102	5	JET SET, PILOT, #40	63	27
	99	6	GEAR A	75	7	JET SET, PILOT, #45	63	27
			GEAR ASSY., DRIVE	87	10		67	44
[D]			GEAR B	87	12	JET, MAIN, #100	63	26
DIAPHRAGM ASSY.	66	24	GEAR, COUNTER	94	14	JET, MAIN, #102	63	26
DOWEL PIN, 12X20	29	12	GEAR, DRIVE PINION	83	7	JET, MAIN, #105	63	26
DOWEL PIN, 8X12	36	13	GEAR, PRIMARY DRIVE	94	3	JET, MAIN, #108	63	26
	38	13	GEAR, REDUCTION	84	11		67	43
	39	12				JET, MAIN, #88	63	26
DOWEL PIN, 8X14	94	11					67	43
							63	26

PART NAME INDEX

Part name	Page	Ref.	Part name	Page	Ref.	Part name	Page	Ref.
JET, MAIN, #90	62	26			24	0-RING, 9.0X1.3	99	4
JET, MAIN, #92	63	26		105	1			
	67	43			2			
JET, MAIN, #95	63	26	MARK, THROTTLE INDICATION	97	21	[P]		
JET, MAIN, #98	67	43	METER ASSY., FUEL	100	25	PACKING	84	16
JOINT, FUEL TANK	76	2	MOTOR ASSY., STARTER	86	1	PACKING, AIR CLEANER	66	23
JOINT, ROD	65	19	MOTOR UNIT, STARTER	83	4	PACKING, AIR CLEANER CASE	67	51
			MUFFLER COMP.	74	1	PACKING, AIR CLEANER ELBOW	73	8
[K]				75	19	PACKING, AIR CLEANER ELBOW	68	1
KEY COMP.	93	12		102	1	PACKING, CARBURETOR	61	16
	99	12	[N]			PACKING, CARBURETOR INSULATOR	65	14
KEY, 6.3X6.3X33	94	8				PACKING, CARBURETOR INSULATOR	61	17
KEY, 6.3X6.3X43	40	7	NOSE, SILENCER	68	6	PACKING, CASE COVER	65	15
KEY, 7X7X33	40	7		73	4	PACKING, CASE COVER	34	2
	94	8	NOZZLE, MAIN	61	11		38	2
KEY, SPECIAL WOODRUFF, 25X18	79	7		65	11	PACKING, CHAIN CASE COVER	39	3
KNOB, COCK LEVER	99	10	NUT-WASHER, 6MM	85	19	PACKING, CHAIN CASE COVER	94	2
			NUT, AIR CLEANER COVER	73	10	PACKING, CRANKCASE COVER	34	2
[L]			NUT, BATTERY TERMINAL	103	10	PACKING, CRANKCASE COVER	38	2
LABEL, CAUTION	95	3	NUT, FLANGE, 10MM	33	11	PACKING, ELBOW	39	3
		4	NUT, FLANGE, 5MM	70	10	PACKING, ELBOW	68	1
	97	23		104	11	PACKING, ELBOW	72	1
		25	NUT, FLANGE, 6MM	67	49	PACKING, FUEL COCK	62	22
	105	5		69	12	PACKING, FUEL FILLER CAP	76	5
LABEL, WARNING	95	1		70	11	PACKING, FUEL FILLER CAP	100	34
LENS ASSY., PROTECTOR	93	14		72	10	PACKING, HEAD COVER	29	7
	99	17		73	12	PACKING, HEAD COVER	61	17
LEVER COMP., CHOKE	61	18		89	23	PACKING, INSULATOR	65	15
LEVER COMP., THROTTLE	91	2	NUT, FLANGE, 8MM	104	12	PACKING, OIL FILLER CAP	35	5
LEVER, CHOKE	65	18		30	18		38	5
LEVER, COCK	62	19		75	12			6
LEVER, CONTROL	89	7		77	10	PANEL COMP., CONTROL	92	5
LIFTER, VALVE	46	5	NUT, HEX., 4MM	100	35	PAN, CLEANER OIL	72	5
	47	5	NUT, HEX., 5MM	93	23	PAN, CLEANER OIL	36	10
			NUT, HEX., 6MM	106	10	PIN, GOVERNOR WEIGHT	38	10
[M]				87	17	PIN, GOVERNOR WEIGHT	39	8
MARK, AIR CLEANER	105	8	NUT, PIVOT ADJUSTING	49	20	PIN, LOCK, 10MM	33	13
		9	NUT, SELF-LOCK, 6MM	89	17	PIN, PISTON	44	3
MARK, AIR CLEANER CAUTION	96	19	NUT, SPECIAL, 16MM	79	18	PIN, SPRING, 2X12	62	25
MARK, CAUTION	105	4	NUT, TOOL BOX SETTING	79	6	PIPE, EX.	29	16
MARK, CHOKE	95	5		69	11		74	4
	96	20	NUT, WING, 6MM	72	9	PISTON	43	2
	97	20		73	11		44	2
	105	6	[O]	69	13	PIVOT, ROCKER ARM	47	6
MARK, CONTROL BOX	93	15				PLATE, BATTERY	103	4
MARK, EX. CAUTION	105	10	OIL SEAL, 30X46X8	94	10	PLATE, BATTERY GUARD	103	1
MARK, OIL ALERT	95	6	OIL SEAL, 35X52X8	32	8	PLATE, BATTERY SETTING	103	2
	96	6		33	8	PLATE, FRICTION	51	5
		18		37	14	PLATE, FRICTION	55	5
	97	26		39	13	PLATE, FUEL INDICATION	105	11
	105	7	OIL SEAL, 8X14X5	33	9	PLATE, LEVER SETTING	62	20
MARK, OIL CAUTION	96	13	0-RING	61	13	PLUG, SPARK	29	15
MARK, OPERATOR CAUTION	95	3		99	1	PROTECTOR COMP., MUFFLER	100	32
	96	7	0-RING, 14MM	33	10	PROTECTOR COMP., MUFFLER	74	2
		17		77	9	PROTECTOR, CIRCUIT	93	13
	97	22	0-RING, 26X2.7	39	14	PROTECTOR, CIRCUIT	99	16
						PROTECTOR, EX. PIPE	74	3

PART NAME INDEX

Part name	Page	Ref.	Part name	Page	Ref.	Part name	Page	Ref.
PROTECTOR, MUFFLER INNER	102	3				SPRING, BRUSH RETURN.....	84	10
PROTECTOR, MUFFLER OUTER	102	2		67	48	SPRING, CABLE RETURN.....	89	14
PULLEY COMP., STARTER	78	2	SCREW SET, DRAIN	60	6	SPRING, CHOKE RETURN.....	91	1
	79	9		64	6	SPRING, COCK LEVER	62	21
PULLEY, RECOIL STARTER	53	3	SCREW SET, PILOT	60	5	SPRING, CONTROL ADJUSTING.....	89	13
PULLEY, STARTER	78	3	SCREW, CENTER	53	11	SPRING, FRICTION.....	51	7
	79	10	SCREW, FLAT, 5X10.....	100	38		53	5
[R]			SCREW, GLOVE BOX	99	20		55	7
RATCHET, STARTER	51	4	SCREW, PAN, 3X12	93	21	SPRING, GOVERNOR.....	88	3
	52	15	SCREW, PAN, 3X6	62	24	SPRING, LEVER	89	8
	53	4	SCREW, PAN, 4X12	93	22	SPRING, MANUAL CHOKE.....	66	22
	55	4	SCREW, PAN, 4X6	89	20	SPRING, RATCHET	53	7
RECTIFIER ASSY., SILICON	92	6	SCREW, PAN, 5X12	67	35	SPRING, RECOIL STARTER	51	8
	99	8	SCREW, PAN, 5X16	89	21		55	8
REEL, RECOIL STARTER	50	3	SCREW, PAN, 5X32	89	22	SPRING, RETURN	51	9
	54	3	SCREW, PAN, 5X35	90	30		52	18
RETAINER, EX. VALVE SPRING ...	48	12	SCREW, PAN, 5X45	90	27		55	9
RETAINER, IN. VALVE SPRING ...	48	11	SCREW, PAN, 5X8	91	5	SPRING, STARTER RETURN.....	53	6
		12	SCREW, RECESSED, 5X25.....	89	26	SPRING, THROTTLE RETURN.....	88	4
			SCREW, SETTING	51	12	SPRING, VALVE	48	10
RETAINER, SPRING	53	8		55	12	SPRING, WEIGHT RETURN.....	47	7
RING SET, PISTON	41	1	SCREW, SPECIAL, 6X12	93	17	STARTER ASSY., RECOIL.....	50	1
	42	1	SCREW, TAPPING, 3X6	58	11		52	14
	43	1	SCREW, TAPPING, 4X6	75	11		53	1
RING, RETAINER	86	9			16		54	1
ROD ASSY., CONNECTING	44	4	SCREW, TAPPING, 4X8	102	7	STARTER SET, RECOIL.....	52	20
	45	4	SCREW, TAPPING, 5X25	106	9	STAY ASSY., MANUAL CHOKE.....	65	16
ROD, CHOKE	65	20	SCREW, TAPPING, 5X8	75	10	STAY COMP., SOLENOID.....	65	17
ROD, CHOKE CONTROL	66	25			16	STAY, AIR CLEANER.....	70	4
ROD, GOVERNOR	88	2		101	42		104	5
ROD, PUSH	46	3	SCREW, TAPPING, 6X10	75	8	STAY, MUFFLER COVER.....	106	15
ROPE, RECOIL STARTER	51	11	SCREW, TAPPING, 6X25	106	17	STOPPER, CHOKE ROD.....	65	21
	53	10	SCREW, THROTTLE STOP	61	10		66	21
	55	11		65	9	STOPPER, DISCHARGE GUARD.....	100	27
ROTATOR, VALVE	48	14	SEAL, AIR CLEANER	70	8	STRAINER COMP., FUEL.....	77	14
RUBBER, BOTTOM	33	17		104	9	STRAP, CABLE, 118MM.....	93	19
		18	SEAL, AIR CLEANER CASE	71	15		101	40
RUBBER, FUEL	77	15	SEAL, AIR CLEANER COVER	71	17	SUB HARNESS	58	8
		19	SEAL, CHOKE LEVER	66	32	SUSPENSION, COUPLER.....	92	7
	99	21	SEAL, MUFFLER PROTECTOR	102	4	SWITCH ASSY., COMBINATION.....	93	11
RUBBER, SUPPORTER	76	1	SEAL, VALVE STEM	46	1		99	11
RUBBER, TANK CUSHION	100	30	SEAT, VALVE SPRING	48	13	SWITCH ASSY., ENGINE KILL.....	99	14
RUBBER, TANK MOUNTING	99	18	SEPARATOR, AIR CLEANER	70	2	SWITCH ASSY., ENGINE STOP.....	57	4
				104	3		58	7
[S]			SHAFT, GOVERNOR ARM	31	2		10	
SCREEN SET, FUEL STRAINER	99	3	SHAFT, P.T.O.	94	5	SWITCH ASSY., OIL LEVEL.....	32	4
SCREW-WASHER, 4X14	85	21	SHROUD	57	3	SWITCH ASSY., STARTER MAGNETIC	87	16
SCREW-WASHER, 4X6	84	15	SLIDER, GOVERNOR	36	11			
SCREW-WASHER, 5X12	67	47		38	11	[T]		
SCREW-WASHER, 5X32	85	18	SOLENOID ASSY.	91	3	TANK COMP., FUEL.....	76	3
SCREW-WASHER, 6X20	106	12	SPACER COMP., CARBURETOR	61	15	TUBE, 11X105.....	29	13
SCREW A	86	7		67	51	TUBE, 3.5X130.....	67	42
SCREW B	86	8	SPACER, CONTROL LEVER	89	11	TUBE, 3.5X75.....	67	41
SCREW C	87	13	SPACER, MUFFLER COVER	106	7	TUBE, BREATHER	29	13
SCREW SET	60	5	SPANNER, 10X12	98	3		30	19
		7	SPANNER, 14X17	98	4		104	1
	64	5	SPRING, AIR CLEANER CASE LID ..	71	13	TUBE, FASTENER, 30MM.....	93	20

PART NAME INDEX

Part name	Page	Ref.	Part name	Page	Ref.	Part name	Page	Ref.
TUBE, FUEL, 4.5X150	77	18						
	99	22						
TUBE, FUEL, 4.5X165	77	18						
TUBE, FUEL, 4.5X180	77	16						
TUBE, FUEL, 4.5X235	77	11						
TUBE, FUEL, 4.5X250	77	18						
[V]								
VALVE ASSY., SOLENOID	67	45						
VALVE SET, FLOAT	59	2						
	63	29						
	64	2						
VALVE, DASHPOT CHECK	66	28						
VALVE, EX.	47	9						
VALVE, IN.	47	8						
[W]								
WASHER	87	11						
		18						
WASHER COMP., HEAD COVER	29	10						
WASHER, 8.2X17X0.8	32	7						
WASHER, 8.5X42X4.5	94	7						
WASHER, CHOKE LEVER	66	31						
WASHER, CONTROL LEVER	89	9						
WASHER, DRAIN PLUG, 12MM	33	12						
WASHER, FRAME JOINT	100	28						
WASHER, LOCK, 8.5X35X4.5	40	6						
WASHER, PLAIN	63	30						
WASHER, PLAIN, 4MM	93	24						
WASHER, PLAIN, 5MM	67	36						
	106	13						
WASHER, PLAIN, 6MM	37	15						
	38	15						
	39	15						
WASHER, SPRING, 4MM	93	25						
WASHER, SPRING, 6MM	87	19						
WASHER, TANK CUSHION	100	29						
WASHER, THRUST, 2.7X8	67	33						
WEIGHT, BALANCER	40	5						
WEIGHT, GOVERNOR	35	8						
	38	8						
	39	6						
WIRE, WATER COVER	84	13						
WRENCH COMP., SPARK PLUG	98	1						
WRENCH, BOX	98	1						
WRENCH, PLUG	99	19						
[Y]								
YOKE COMP.	84	9						

1

FOREWORD INDEX

2

ENGINE GROUP

3

PART NUMBER INDEX

4

PART NAME INDEX

HONDA

HONDA PARTS CATALOGUE NEWS

PARTS CATALOGUE - CORRECTED

CODE NO.	13Z7E803
PARTS CATALOGUE NEWS	GX390H1 GX390H2
NEWS NO.	001

Block No.	Ref. No.	Note	Part No.	Description	Reqd. QTY		Serial No.	Parts catalogue code
					GX 390 H1	GX 390 H2		
E-14-1	16	T	16260-27E-000	STAY ASSY., MANUAL CHOKE.....	1	-	-----	EDF6, EDS2, VPKK, VPXB, VPXE, VPXJ, VPXK, VPXX, VXEK, VXKS
					1	-	0002757	EDT1
		T	16260-27E-800	1	-	-----	EDS1, EDS2, EDT1, ES2, VPKK, VPXB, VPXE, VPXK, VPXX, VXEK, VXKS
					1	-	0000671	ES2, ES3S, ES4S, VMQ3, VMT3, VS4, VS6, VSB4
E-17	18	E	95001-45165-40	*PART NO. DELETION				
		D	95001-45210-40	TUBE, FUEL, 4.5X210 (95001-45001-60M)	1	-	-----	EDF6
E-22	3	T	16561-ZE3-000	SPRING, GOVERNOR (L=137.5MM)...	1	-	-----	EDS1, EDS2, EDT1, ES2, ES3S, ES4S, LH, LH1, LH2, LHB5, LHP1, LXE9, PXQA2, QBE1, QEBR, QH, QH1, QHB1, QHB3, QHB5, QHBR, QHE, QHP1, QMH, QN, QPQX, QXBR, QXE, QXEK, QXHQ, QXK, SH, SH1, SHE, SM11, SWE2, SWX2, SX, SX1, SXC, SXC1, SXE, SXE1, VMQ3, VMT3, VS4, VS6, VSB4, VTE5
					-	1	-----	LH, LH1, PX, QH, QH1, QHE, QMH, QN, QX, QXE, QXHQ, SH, SH1, SHE, SM11, SWX2, SX, SX1, SXC, SXC1, VTE5, VX, VX1, VX1M, VXE, VXEM
		T	16561-ZF6-W32	SPRING, GOVERNOR.....	1	-	-----	VX, VX1, VX1M, VXE, VXEM
E-40	17	T	38250-898-000	LENS ASSY., PROTECTOR.....	1	1	-----	EDS1, EDS2
E-40-4	4	T	87522-883-660	MARK, CAUTION (ENGLISH/FRENCH/SPANISH)	1	1	-----	EDS1, EDS2, EDT1

NOTE A:PART NO. CHANGE D:NEWLY PROVIDED E:PART NO.DELETION K:REQUIRED NO. CORRECTION L:APPLICATION SERIAL NO. CORRECTION
M:PART DESCRIPTION CORRECTION T:APPLICATION CORRECTION Z:REMARKS CHANGE

HONDA PARTS CATALOGUE NEWS

PARTS CATALOGUE - CORRECTED

CODE NO.	13Z7E803
PARTS CATALOGUE NEWS	GX390H1 GX390H2
NEWS NO.	002

Block No.	Ref. No.	Note	Part No.	Description	Reqd. QTY		Serial No.	Parts catalogue code
					GX 390 H1	GX 390 H2		
E-14	17	T	16212-Z7E-701	PACKING, INSULATOR (NINGBO SIL GASKET)	1	-	-----	LH, LH1, LH2, LHB5, LHP1, LXE9, PX, QA2, QBE1, QEBR, QH, QH1, QHB1, QHB3, QHB5, QHBR, QHE, QHP1, QMH, QN, QP, QX, QXBR, QXE, QXEK, QXHQ, QXK, SH, SH1, SHE, SM11, SWE2, SWX2, SX, SX1, SXC, SXC1, SXE, SXE1, VSP, VTE5, VX, VX1, VX1M, VXE, VXEM, VXK, VXU1
					-	1		
E-40	16	T	38240-VA3-900	PROTECTOR, CIRCUIT (1.0A).....	1	-	-----	EDF6, EDS1, EDS2

NOTE A:PART NO. CHANGE D:NEWLY PROVIDED E:PART NO.DELETION K:REQUIRED NO. CORRECTION L:APPLICATION SERIAL NO. CORRECTION
M:PART DESCRIPTION CORRECTION T:APPLICATION CORRECTION Z:REMARKS CHANGE

HONDA PARTS CATALOGUE NEWS

PARTS CATALOGUE - CORRECTED

CODE NO.	13Z7E803
PARTS CATALOGUE NEWS	GX390H1 GX390H2
NEWS NO.	003

Block No.	Ref. No.	Note	Part No.	Description	Reqd. QTY		Serial No.	Parts catalogue code	
					GX 390 H1	GX 390 H2			
E-20	6	T	36101-ZE2-701	CORD, STOP SWITCH(430MM).....	1	-	-----	LH1, LH2, LHB5, LHP1, LXE9, PX, QA2, QBE1, QEBR, QH, QH1, QHB1, QHB3, QHB5, QHBR, QHE, QHP1, QMH, QN, QP, QX, QXBR, QXE, QXEK, QXHQ, QXK, SH, SH1, SHE, SM11, SWE2, SWX2, SX, SX1, SXC, SXC1, SXE, SXE1, VMT3, VPKK, VPX4, VPXB, VPXE, VPXJ, VPXK, VPXX, VSP, VTE5, VX, VX1, VX1M, VXE, VXEK, VXEM, VVK, VXKS, VXU1	
	7	T	36103-V42-000	HOLDER, STOP SWITCH CORD.....	1	-	-----	ES2, LH, LH1, QEBR, QH, QH1, QHB1, QHBR, QHE, QHP1, QMH, QN, QXE, SH, SH1, SHE, SM11, SWE2, SXE, VTE5, VXE, VXEM	
						-	1	-----	QHE, QXE, SHE, VTE5, VXE, VXEM
	11	T	90684-Z7E-000	CLIP, HARNESS.....	1	-	-----	PX, QA2, QX, QXBR, QXHQ, QXK, SWX2, SX, SX1, SXC, SXC1, VPXB, VX, VX1, VX1M, VXKS	
						1	-	0011401	EDT1, VPX4, VSP
					-	1	-----	EDT1, ES2, LH, LH1, PX, QH, QH1, QMH, QN, QX, QXHQ, SH, SH1, SM11, SWX2, SX, SX1, SXC, SXC1, VPXB, VX, VX1, VX1M, VXKS	
	17	T	32110-Z5K-000	HARNESS ASSY., ENGINE WIRE....	-	1	-----	EDT1, ES2, PX, QX, QXHQ, SWX2, SX, SX1, SXC, SXC1, VPXB, VX, VX1, VX1M, VXKS	
E-28	19	T	87524-Z0S-801	MARK, AIR CLEANER CAUTION (OIL BATH)	1	-	-----	SWE2, SWX2	

NOTE A:PART NO. CHANGE D:NEWLY PROVIDED E:PART NO.DELETION K:REQUIRED NO. CORRECTION L:APPLICATION SERIAL NO. CORRECTION
M:PART DESCRIPTION CORRECTION T:APPLICATION CORRECTION Z:REMARKS CHANGE

HONDA PARTS CATALOGUE NEWS

PARTS CATALOGUE - CORRECTED

CODE NO.	13Z7E803
PARTS CATALOGUE NEWS	GX390H1 GX390H2
NEWS NO.	004

Block No.	Ref. No.	Note	Part No.	Description	Reqd. QTY		Serial No.	Parts catalogue code	
					GX 390 H1	GX 390 H2			
E-20	1	E	30500-27E-003	*PART NO. DELETION					
		D	30100-27E-305	COIL ASSY., IGNITION & CAP ASSY., NOISE SUPPRESSOR	1	-	-----	-----	EDS2, ES2, ES3S, ES4S, LH1, LH2, LHB5, LHP1, LXE9, PX, QA2, QBE1, QEBR QH, QH1, QHB1, QHB3, QHB5, QHBR, QHE, QHP1, QMH, QN, QP, QX, QXBR, QXE QXEK, QXHQ, QXK, SH, SH1, SHE, SM11, SWE2, SWX2, SX, SX1, SXC, SXC1, SXE SXE1, VMQ3, VMT3, VPKK, VPXB, VPXE, VPXJ, VPXK, VPXX, VS4, VS6, VSB4 VSP, VTE5, VX, VX1, VXE, VXEK, VXK, VXKS, VXU1
					1	-	-----	0284342	LH
					1	-	-----	0001592	EDS1, EDT1
					1	-	-----	0002905	VPX4
	2	E	30700-21T-003	*PART NO. DELETION					
E-21-1	3	D	31212-27E-003	ARMATURE ASSY.	-	1	-----	-----	EDS1, EDS2, QHE, SHE, VPKK, VPXE, VPXK, VPXX, VXEK

NOTE A:PART NO. CHANGE D:NEWLY PROVIDED E:PART NO.DELETION K:REQUIRED NO. CORRECTION L:APPLICATION SERIAL NO. CORRECTION
M:PART DESCRIPTION CORRECTION T:APPLICATION CORRECTION Z:REMARKS CHANGE

HONDA

PARTS CATALOGUE NEWS

PARTS CATALOGUE - CORRECTED

CODE NO.	13Z7E803
PARTS CATALOGUE NEWS	GX390H1 GX390H2
NEWS NO.	005

Block No.	Ref. No.	Note	Part No.	Description	Reqd. QTY		Serial No.	Parts catalogue code
					GX 390 H1	GX 390 H2		
E-20	1	E	30100-27E-003	*PART NO. DELETION				
		D	30100-27E-305	COIL ASSY., IGNITION & CAP ASSY., NOISE SUPPRESSOR	1	-	----- 0838568	EDS2, ES2, ES3S, ES4S, VS4, VS6, VSB4
					1	-	----- 0838866	LH, LH1, LH2, LHB5, LHP1, LXE9, PX, QA2, QBE1, QEBR, QH, QH1, QHB1, QHB3, QHB5, QHBR, QHE, QHP1, QMH, QN, QP, QX, QXBR, QXE, QXEK, QXHQ, QXK, SH, SH1, SHE, SM11, SWE2, SWX2, SX, SX1, SXC, SXC1, SXE, SXE1, VMT3, VPKK, VPXB, VPXE, VPXJ, VPXK, VPXX, VSP, VTE5, VX, VX1, VXE, VXEK, VVK, VXKS, VXU1
					1	-	0001592 0838568	EDS1, EDT1
					1	-	0002905 0838866	VPX4
	2	T	30700-21T-601	CAP ASSY., NOISE SUPPRESSOR (TOYO)	1	-	-----	EDF6, VX1M, VXEM
					1	-	0838569	EDS1, EDS2, EDT1, ES2, ES3S, ES4S, VS4, VS6, VSB4
					1	-	0838867	LH, LH1, LH2, LHB5, LHP1, LXE9, PX, QA2, QBE1, QEBR, QH, QH1, QHB1, QHB3, QHB5, QHBR, QHE, QHP1, QMH, QN, QP, QX, QXBR, QXE, QXEK, QXHQ, QXK, SH, SH1, SHE, SM11, SWE2, SWX2, SX, SX1, SXC, SXC1, SXE, SXE1, VMT3, VPKK, VPX4, VPXB, VPXE, VPXJ, VPXK, VPXX, VSP, VTE5, VX, VX1, VXE, VXEK, VVK, VXKS, VXU1
	12	T	30500-27E-601	COIL ASSY., IGNITION.....	1	-	-----	EDF6, VX1M, VXEM
					1	-	0838569	EDS1, EDS2, EDT1, ES2, ES3S, ES4S, VS4, VS6, VSB4

NOTE A:PART NO. CHANGE D:NEWLY PROVIDED E:PART NO.DELETION K:REQUIRED NO. CORRECTION L:APPLICATION SERIAL NO. CORRECTION
M:PART DESCRIPTION CORRECTION T:APPLICATION CORRECTION Z:REMARKS CHANGE

PARTS CATALOGUE NEWS

BOOKNo. : 13Z7E803

Block No.	Ref. No.	Note	Part No.	Description	Reqd. QTY		Serial No.	Parts catalogue code
					GX 390 H1	GX 390 H2		
					1	-	0838867 -----	LH, LH1, LH2, LHB5, LHP1, LXE9, PX, QA2, QBE1, QEBR, QH, QH1, QHB1, QHB3, QHB5, QHBR, QHE, QHP1, QMH, QN, QP, QX, QXBR, QXE, QXEK, QXHQ, QXK, SH, SH1, SHE, SM11, SWE2, SWX2, SX, SX1, SXC, SXC1, SXE, SXE1, VMQ3, VMT3, VPKK, VPX4, VPXB, VPXE, VPXJ, VPXK, VPXX, VSP, VTE5, VX, VX1, VXE, VXEK, VXK, VXKS, VXU1

NOTE A:PART NO. CHANGE D:NEWLY PROVIDED E:PART NO.DELETION K:REQUIRED NO. CORRECTION L:APPLICATION SERIAL NO. CORRECTION
M:PART DESCRIPTION CORRECTION T:APPLICATION CORRECTION Z:REMARKS CHANGE

HONDA

PARTS CATALOGUE NEWS

PARTS CATALOGUE - CORRECTED

CODE NO.	13Z7E803
PARTS CATALOGUE NEWS	GX390H1 GX390H2
NEWS NO.	006

Block No.	Ref. No.	Note	Part No.	Description	Reqd. QTY		Serial No.	Parts catalogue code
					GX 390 H1	GX 390 H2		
E-20	6	T	32195-Z7E-701	CORD, STOP SWITCH(430MM).....	1	-	0284343 -----	LH
				(30500-Z7E-701)	1	-	0650383 -----	LH1, LH2, LHB5, LHP1, LXE9, PX, QA2, QBE1, QEBR, QH, QH1, QHB1, QHB3, QHB5, QHBR, QHP1, QMH, QN, QP, QX, QXBR, QXE, QXEK, QXHQ, QXK, SH, SH1, SHE, SM11, SWE2, SWX2, SX, SX1, SXG, SXC1, SXE, SXE1, VMO3, VMT3, VPX4, VPXB, VPXE, VPXJ, VPXK, VSP, VTE5, VX, VX1, VXE, VXK, VXU1
				(30500-Z7E-701)	1	-	-----	QHE, VPKK, VPXX, VX1M, VXEK, VXEM, VXKS

NOTE A:PART NO. CHANGE D:NEWLY PROVIDED E:PART NO.DELETION K:REQUIRED NO. CORRECTION L:APPLICATION SERIAL NO. CORRECTION
M:PART DESCRIPTION CORRECTION T:APPLICATION CORRECTION Z:REMARKS CHANGE

HONDA PARTS CATALOGUE NEWS

CODE NO.	13Z7E803
PARTS CATALOGUE NEWS	GX390H1 GX390H2
NEWS NO.	007

GX390H2-QHG TYPE sales parts information

NOTE: This Parts Catalogue News explains only the parts of the different model that are produced to conform to addition of the GX390H2-QHG type.

As for the parts not listed on this Parts Catalogue News, use the parts of the GX390H2-QH type.

• Models, parts catalogue codes and applicable serial numbers

Model	Type		Parts catalogue type	Applicable engine serial No.	Applicable carburetor identification No.
GX390H2	QH	Base type	QH	GCBBH-1000001~	BEA6JA
	QHG	Additional type	QHG		

BOOKNo. : 13Z7E803

• Features of each type		Base type	Additional type
Model		GX390H2	
Specifications		QH	QHG
Crankshaft	25mm Ø X 117mm Straight		
	25.4mm Ø X 142.5mm Straight	●	●
	5/ 16" Tapered		
	35mm Ø Tapered		
	30mm Ø Spline		
	25.4mm Ø Spline		
Oil alert			
Oil level switch			
Charge coil			
Starter motor			
Control box			
Reduction			

NOTE A:PART NO. CHANGE D:NEWLY PROVIDED E:PART NO.DELETION K:REQUIRED NO. CORRECTION L:APPLICATION SERIAL NO. CORRECTION
M:PART DESCRIPTION CORRECTION T:APPLICATION CORRECTION Z:REMARKS CHANGE

PARTS CATALOGUE NEWS

BOOKNo. : 13Z7E803

Block No.	Ref. No.	Part No.	Description	Reqd. QTY		Base Part No.	Parts catalogue code
				GX 390 H1	GX 390 H2		
E-3	1	12000-Z5T-416	BARREL ASSY., CYLINDER.....	-	1	12000-Z5T-406	QHG
	15	91004-KZR-602	BEARING, RADIAL BALL, 6202 (FUJIKOSHI)	-	1		QHG
E-6	1	11300-Z7E-801	COVER ASSY., CRANKCASE.....	-	1	11300-Z7E-800	QHG
E-11-2	1		STARTER ASSY., RECOIL *NH1*..... BLACK	-	0	28400-Z7E-702ZB	QHG
	2		CASE COMP., RECOIL STARTER *NH1*..... BLACK	-	0	28410-Z7E-701ZB	QHG
E-12	2		COVER COMP., FAN *NH1*..... BLACK	-	0	19610-Z5T-000ZB	QHG
E-17	2		JOINT, FUEL TANK.....	-	0	16955-Z1T-010	QHG
	3		TANK COMP., FUEL *NH1*..... BLACK	-	0	17510-Z5T-000ZA	QHG
			TANK COMP., FUEL *NH31*..... MCKINLEY WHITE	-	0	17510-Z5T-000ZB	QHG
	4		CAP COMP., FUEL FILLER (CHROME PLATED) (TOYOSHA)	-	0	17620-Z1T-800	QHG
	5		PACKING, FUEL FILLER CAP (39X62X3) (TOYOSHA)	-	0	17631-Z1T-800	QHG
	9		O-RING, 14MM (NOK).....	-	0	91353-671-004	QHG
	10		NUT, FLANGE, 8MM.....	-	0	94050-08000	QHG
	13		BOLT, FLANGE, 8X25.....	-	0	95701-08025-00	QHG
E-40-4	1	87516-ZK6-811	MARK, OPERATOR CAUTION (CHINESE) (MADE IN CHINA)	-	1		QHG

NOTE A:PART NO. CHANGE D:NEWLY PROVIDED E:PART NO.DELETION K:REQUIRED NO. CORRECTION L:APPLICATION SERIAL NO. CORRECTION
M:PART DESCRIPTION CORRECTION T:APPLICATION CORRECTION Z:REMARKS CHANGE

HONDA PARTS CATALOGUE NEWS

PARTS CATALOGUE - CORRECTED

CODE NO.	13Z7E803
PARTS CATALOGUE NEWS	GX390H1 GX390H2
NEWS NO.	008

Block No.	Ref. No.	Note	Part No.	Description	Reqd. QTY		Serial No.	Parts catalogue code			
					GX 390 H1	GX 390 H2					
E-2	16	T	18330-ZE3-710	PIPE, EX.....	1	1	-----	EDF6, EDS1, EDT1, ES2, ES3S, ES4S, VMT3, VS4, VS6, VSB4			
	17	T	18333-ZF6-W01	GASKET, EX. PIPE.....	1	-	-----	EDF6, EDS1, EDT1, ES2, ES3S, ES4S, VMQ3, VMT3, VS4, VS6, VSB4			
					-	1	-----	EDS1, EDT1, ES2, VPKK, VPXE, VPXK, VPXX			
	18	T	94050-08000	NUT, FLANGE, 8MM.....	2	2	-----	EDF6, EDS1, EDT1, ES2, ES3S, ES4S, VMQ3, VMT3, VS4, VS6, VSB4			
E-14-1	44	L	99204-ZA0-0450	JET SET, PILOT, #45.....	1	-	-----	EDF6, EDS1, EDS2, EDT1, ES2, ES3S, ES4S, VMQ3, VMT3, VPXJ, VS4, VS6, VSB4, VXEK, VXKS			
					1	-	-----	1001462 VPKK, VPX4, VPXB, VPXE, VPXK, VPXX			
	T	99204-ZE0-0450	1	-	-----	1001463 VPKK, VPX4, VPXB, VPXE, VPXK, VPXX				
				-	1	-----	EDS1, EDS2, EDT1, ES2, VPKK, VPXB, VPXE, VPXK, VPXX, VXEK, VXKS				
E-28	17	E	87516-ZCL-801	*PART NO. DELETION							
					T	87516-Z1V-800	MARK, OPERATOR CAUTION.....	1	-	-----	ES2
					D	87516-Z1V-801	-	1	-----	ES2
	D	87516-ZCL-801	MARK, OPERATOR CAUTION(KOREA).	-	1	-----	VXEK, VXKS				
				24	E	87516-Z1V-800	*PART NO. DELETION				
	D	87516-Z1V-801	MARK, OPERATOR CAUTION.....	-	1	-----	SWX2				
				25	E	87522-Z1T-G21	*PART NO. DELETION				

NOTE A:PART NO. CHANGE D:NEWLY PROVIDED E:PART NO. DELETION K:REQUIRED NO. CORRECTION L:APPLICATION SERIAL NO. CORRECTION
M:PART DESCRIPTION CORRECTION T:APPLICATION CORRECTION Z:REMARKS CHANGE

PARTS CATALOGUE NEWS

BOOKNo. : 13Z7E803

Block No.	Ref. No.	Note	Part No.	Description	Reqd. QTY		Serial No.	Parts catalogue code
					GX 390 H1	GX 390 H2		
		D	87522-Z1T-G22	LABEL, CAUTION.....	-	1	-----	LH1, PX, QH1, QMH, QN, QX, QXE, SH1, SX1, SXC1, VX1, VX1M, VXE, VXEM
E-29	1	T	89218-ZE1-000	WRENCH COMP., SPARK PLUG.....	1	1	-----	EDS2, LHB5, LHP1, QA2, QHB3, QHB5, QHP1, QMH, QN, QP, SM11, SWX2, VPKK VPXX, VSB4
E-40	1	T	16173-001-004	O-RING.....	1	1	-----	EDS1, EDT1, ES2, ES3S, ES4S, VMQ3, VMT3, VS4, VS6, VSB4
	2	T	16950-ZB4-015	COCK ASSY., FUEL.....	1	1	-----	EDS1, EDT1, ES2, ES3S, ES4S, VMQ3, VMT3, VS4, VS6, VSB4
	3	T	16952-ZB4-005	SCREEN SET, FUEL STRAINER.....	1	1	-----	EDS1, EDT1, ES2, ES3S, ES4S, VMQ3, VMT3, VS4, VS6, VSB4
	4	T	16958-397-771	O-RING, 9.0X1.3.....	1	1	-----	EDS1, EDT1, ES2, ES3S, ES4S, VMQ3, VMT3, VS4, VS6, VSB4
	5	T	16959-471-831	FILTER, CUP.....	1	1	-----	EDS1, EDT1, ES2, ES3S, ES4S, VMQ3, VMT3, VS4, VS6, VSB4
	6	T	16967-GA6-671	CUP, FUEL STRAINER.....	1	1	-----	EDS1, EDT1, ES2, ES3S, ES4S, VMQ3, VMT3, VS4, VS6, VSB4
	7	T	30561-ZB4-000	CLIP, WIRE.....	1	1	-----	EDS1, EDT1
	16	L	38240-VA3-900	PROTECTOR, CIRCUIT(1.0A).....	1	-	----- 0982701	EDF6, EDS1, EDS2
	17	T	38250-898-000	LENS ASSY., PROTECTOR.....	1	1	-----	EDS1
	18	T	50319-ZB2-000	RUBBER, TANK MOUNTING.....	2	2	-----	EDS1, EDT1, ES2, VMQ3, VMT3, VSB4
	19	T	89216-ZB4-000	WRENCH, PLUG.....	1	1	-----	EDS1, EDT1, ES2, ES3S, ES4S, VMQ3, VMT3, VS4, VS6
	20	T	90101-692-000	SCREW, GLOVE BOX.....	1	1	-----	EDS1, EDT1
	21	T	90854-ZB2-000	RUBBER, FUEL(9X15X10).....	1	-	-----	EDS1, EDS2, EDT1, ES3S, ES4S
					-	1	-----	EDS2
	22	T	95001-45150-40	TUBE, FUEL, 4.5X150 (95001-45001-60M)	1	1	-----	EDS1, EDT1, ES3S, ES4S
		D	95001-45210-40	TUBE, FUEL, 4.5X210 (95001-45001-60M)	1	1	-----	EDS2
E-40-1	1	T	18310-ZD1-E32	MUFFLER COMP. (SANKEI).....	1	1	-----	EDS1, EDT1, ES3S, ES4S
	2	T	18320-ZG2-000	PROTECTOR, MUFFLER OUTER.....	1	1	-----	EDS1, EDT1, ES2, ES3S, ES4S, VMQ3, VMT3, VS4, VS6, VSB4
	3	T	18325-ZB4-000	PROTECTOR, MUFFLER INNER.....	1	1	-----	EDS1, EDT1, ES2, ES3S, ES4S, VMQ3, VMT3, VS4, VS6, VSB4
	4	T	18329-ZB4-000	SEAL, MUFFLER PROTECTOR.....	2	2	-----	EDS1, EDT1, ES2, ES3S, ES4S, VMQ3, VMT3, VS4, VS6, VSB4
	6	T	18355-ZB4-630	ARRESTER, SPARK.....	1	1	-----	EDS1, EDT1

NOTE A:PART NO. CHANGE D:NEWLY PROVIDED E:PART NO. DELETION K:REQUIRED NO. CORRECTION L:APPLICATION SERIAL NO. CORRECTION
M:PART DESCRIPTION CORRECTION T:APPLICATION CORRECTION Z:REMARKS CHANGE

PARTS CATALOGUE NEWS

BOOKNo. : 13Z7E803

Block No.	Ref. No.	Note	Part No.	Description	Reqd. QTY		Serial No.		Parts catalogue code
					GX 390 H1	GX 390 H2			
	7	T	90002-ZE2-U91	SCREW, TAPPING, 4X8.....	1	1	-----	-----	EDS1, EDT1
	8	T	95701-06010-00	BOLT, FLANGE, 6X10.....	1	1	-----	-----	EDS1, EDT1, VMQ3, VMT3
	9	T	95701-06012-00	BOLT, FLANGE, 6X12.....	7	7	-----	-----	EDS1, EDT1
E-40-4	4	T	87522-883-660	MARK, CAUTION (ENGLISH/FRENCH/SPANISH)	1	1	-----	-----	EDS1, EDT1
	5	T	87522-Z1T-G21	LABEL, CAUTION.....	1	-	-----	-----	VTE5
		D	87522-Z1T-G22	-	1	-----	-----	VTE5
	8	T	87533-Z7E-800	MARK, AIR CLEANER (CHINESE)....	1	-	-----	-----	VPXB, VPXE, VPXJ, VPXK
					1	-	0010335	-----	EDS1, EDT1, VPX4
					-	1	-----	-----	EDS1, EDT1, VPXB, VPXE, VPXK
	9	T	87533-ZC0-630	MARK, AIR CLEANER (ENGLISH)....	1	1	-----	-----	EDF6, EDS2, ES2, ES3S, ES4S, VMQ3, VMT3, VPXK, VPXX, VS4, VS6, VSB4, VXEK, VXKS
					(1)	(1)	-----	-----	VPXK, VPX4, VPXB, VPXE, VPXJ, VPXK, VPXX, VXEK, VXKS
					1	-	0010334	-----	EDS1, EDT1

NOTE A:PART NO. CHANGE D:NEWLY PROVIDED E:PART NO. DELETION K:REQUIRED NO. CORRECTION L:APPLICATION SERIAL NO. CORRECTION
M:PART DESCRIPTION CORRECTION T:APPLICATION CORRECTION Z:REMARKS CHANGE

HONDA PARTS CATALOGUE NEWS

PARTS CATALOGUE - CORRECTED

CODE NO.	13Z7E803
PARTS CATALOGUE NEWS	GX390H1 GX390H2
NEWS NO.	009

Block No.	Ref. No.	Note	Part No.	Description	Reqd. QTY		Serial No.	Parts catalogue code	
					GX 390 H1	GX 390 H2			
E-14-1	6	T	16024-124-760	SCREW SET, DRAIN.....	1	-	-----	EDF6, ES2, ES3S, ES4S, VMQ3, VMT3, VPKK, VPX4, VPXB, VPXE, VPXJ VPXK, VPXX, VS4, VS6, VSB4, VXEK, VXKS	
				(CARBURETOR NO.)	1	-	BE87G B	-----	EDS1, EDS2, EDT1
					-	1	-----	EDS1, EDS2, EDT1, ES2, VPKK, VPXB, VPXE, VPXK, VPXX, VXEK, VXKS	
	L	16024-124-761	(CARBURETOR NO.)	1	-	-----	BE87G A	EDS1, EDS2, EDT1	
				1	-	-----	EDF6		
	7	T	16028-Z7E-E61	SCREW SET.....	1	-	-----	EDF6	
				(CARBURETOR NO.)	1	-	BE87G B	-----	EDS1, EDS2, EDT1
					-	1	-----	EDS1, EDS2, EDT1, ES2, VXEK, VXKS	
	L	16028-ZA0-931	(CARBURETOR NO.)	1	-	-----	-----	ES2, ES3S, ES4S, VMQ3, VMT3, VS4, VS6, VSB4, VXEK, VXKS	
				1	-	-----	BE87G A	EDS1, EDS2, EDT1	
8	L	16100-ZF6-V41	CARBURETOR ASSY. (BE87G A).....	1	-	-----	0920555	EDS1, EDS2, EDT1	
			T	16100-ZF6-V42	CARBURETOR ASSY. (BE87G B).....	1	-	-----	EDF6
					1	-	0920556	-----	EDS1, EDS2, EDT1

NOTE A:PART NO. CHANGE D:NEWLY PROVIDED E:PART NO. DELETION K:REQUIRED NO. CORRECTION L:APPLICATION SERIAL NO. CORRECTION
M:PART DESCRIPTION CORRECTION T:APPLICATION CORRECTION Z:REMARKS CHANGE

HONDA PARTS CATALOGUE NEWS

CODE NO.	13Z7E803
PARTS CATALOGUE NEWS	GX390H1 GX390H2
NEWS NO.	010

GX390H2- QHEG TYPE sales parts information

NOTE: This Parts Catalogue News explains only the parts of the different model that are produced to conform to addition of the GX390H2-QHEG type.

As for the parts not listed on this Parts Catalogue News, use the parts of the GX390H2-QHE type.

• **Models, parts catalogue codes and applicable serial numbers**

Model	Type		Parts catalogue type	Applicable engine serial No.	Applicable carburetor identification No.
GX390H2	QHE	Base type	QHE	GCBBH-1000001~	BEA6J A
	QHEG	Additional type	QHEG		

• Features of each type		Base type	Additional type
Model		GX390H2	
Type		QHE	QHEX
Specifications			
Crankshaft	25mm Ø X 117mm Straight		
	25.4mm Ø X 142.5mm Straight	●	●
	5/16" Tapered		
	35mm Ø Tapered		
	30mm Ø Spline		
	25.4mm Ø Spline		
Oil alert			
Oil level switch			
Charge coil		●	●
Starter motor		●	●
Control box		●	●
Reduction			

PARTS CATALOGUE NEWS

BOOKNo. : 13Z7E803

Block No.	Ref. No.	Part No.	Description	Reqd. QTY		Base Part No.	Parts catalogue code
				GX 390 H1	GX 390 H2		
E-3	1	12000-Z5T-418	BARREL ASSY., CYLINDER.....	-	1	12000-Z5T-408	QHEG
	15	91004-KZR-602	BEARING, RADIAL BALL, 6202 (FUJIKOSHI)	-	1		QHEG
E-6	1	11300-Z7E-801	COVER ASSY., CRANKCASE.....	-	1	11300-Z7E-800	QHEG
E-11-2	1		STARTER ASSY., RECOIL *NH1*..... BLACK	-	0	28400-Z7E-702ZB	QHEG
	2		CASE COMP., RECOIL STARTER *NH1*..... BLACK	-	0	28410-Z7E-701ZB	QHEG
E-12	2		COVER COMP., FAN *NH1*..... BLACK	-	0	19610-Z5T-000ZB	QHEG
E-17	2		JOINT, FUEL TANK.....	-	0	16955-Z1T-010	QHEG
	3		TANK COMP., FUEL *NH1*..... BLACK	-	0	17510-Z5T-000ZA	QHEG
			TANK COMP., FUEL *NH31*..... MCKINLEY WHITE	-	0	17510-Z5T-000ZB	QHEG
	4		CAP COMP., FUEL FILLER (CHROME PLATED) (TOYOSHA)	-	0	17620-Z1T-800	QHEG
	5		PACKING, FUEL FILLER CAP (39X62X3) (TOYOSHA)	-	0	17631-Z1T-800	QHEG
	9		O-RING, 14MM (NOK).....	-	0	91353-671-004	QHEG
	10		NUT, FLANGE, 8MM.....	-	0	94050-08000	QHEG
	13		BOLT, FLANGE, 8X25.....	-	0	95701-08025-00	QHEG
E-23	2		BOX ASSY., CONTROL (EXTERNAL) *NH1*..... BLACK	-	0	31610-Z5T-811ZA	QHEG
	5		PANEL COMP., CONTROL *NH1*..... BLACK	-	0	31615-ZE3-003ZA	QHEG
E-40-4	1	87516-ZK6-811	MARK, OPERATOR CAUTION (CHINESE) (MADE IN CHINA)	-	1		QHEG

HONDA PARTS CATALOGUE NEWS

PARTS CATALOGUE - CORRECTED

CODE NO.	13Z7E803
PARTS CATALOGUE NEWS	GX390H1 GX390H2
NEWS NO.	011

Block No.	Ref. No.	Note	Part No.	Description	Reqd. QTY		Serial No.	Parts catalogue code
					GX 390 H1	GX 390 H2		
E-2	16	L	18330-ZE3-710	PIPE, EX.....	1	-	-----	EDF6, EDS1, EDT1, ES2, ES3S, ES4S, VMT3, VS4, VS6, VSB4
					-	1	-----	ES2
					-	1	-----	1018479 EDS1, EDT1
	17	L	18333-ZF6-W01	GASKET, EX. PIPE.....	1	-	-----	EDF6
					-	1	-----	ES2, VPKK, VPXE, VPXK, VPXX
					-	1	-----	1062905 EDS1, EDT1
	18	L	94050-08000	NUT, FLANGE, 8MM.....	2	-	-----	EDF6, EDS1, EDT1, ES2, ES3S, ES4S, VMQ3, VMT3, VS4, VS6, VSB4
					-	2	-----	ES2
					-	2	-----	1062905 EDS1, EDT1
E-6-1	1		11300-Z7E-810	COVER ASSY., CRANKCASE.....	1	-	-----	LH2, LHB5, LHP1, LXE9
					1	-	-----	1030005 LH, LH1
					-	1	-----	1005979 LH, LH1
					1	-	-----	1030006 LH, LH1
	A		11300-Z7E-811	1	-	-----	1005980 LH, LH1

NOTE A:PART NO. CHANGE D:NEWLY PROVIDED E:PART NO. DELETION K:REQUIRED NO. CORRECTION L:APPLICATION SERIAL NO. CORRECTION
M:PART DESCRIPTION CORRECTION T:APPLICATION CORRECTION Z:REMARKS CHANGE

PARTS CATALOGUE NEWS

BOOKNo. : 13Z7E803

Block No.	Ref. No.	Note	Part No.	Description	Reqd. QTY		Serial No.	Parts catalogue code		
					GX 390 H1	GX 390 H2				
E-14	27		99204-ZA0-0450	JET SET, PILOT, #45.	1	-	-----	LH, LH1, LH2, LHB5, LHP1, LXE9, PX, QA2, QH, QH1, QHB3, QHB5, QHE, QHP1, QMH, QN, QX, QXE, QXEK, QXHQ, QXK, SH, SH1, SHE, SM11, SX, SX1, SXC, SXC1, SXE, SXE1, VSP, VX, VX1, VX1M, VXE, VXEM, VXX, VXU1		
					1	-	-----	1044338	QEBR, QHBR, QXBR	
		A	99204-ZE0-0450	1	-	-----	1044339	QEBR, QHBR, QXBR	
E-21	3	L	31207-ZE3-003	CLUTCH COMP., OVERRUNNING.	1	-	-----	ES4S, LXE9, QBE1, QXEK, SWE2, SXE1, VMT3, VS6, VXX, VXU1		
					1	-	-----	0287079	EDS1, SHE, SXE, VPXE	
			T	31208-ZE3-003	1	-	-----	1047627	QEBR, QXE, VTE5, VXE, VXEM
						1	-	-----	1047628	QEBR, QXE, VTE5, VXE, VXEM
					-	1	-----	-----	QXE, VTE5, VXE, VXEM	
	4	L	31210-ZE3-023	MOTOR UNIT, STARTER.	1	-	-----	ES4S, LXE9, QBE1, QXEK, SWE2, SXE1, VMT3, VS6, VXX, VXU1		
					1	-	-----	0287079	EDS1, SHE, SXE, VPXE	
			T	31210-ZE3-033	1	-	-----	1047627	QEBR, QXE, VTE5, VXE, VXEM
					1	-	-----	1047628	QEBR, QXE, VTE5, VXE, VXEM	
				-	1	-----	-----	QXE, VTE5, VXE, VXEM		
E-40	7	L	30561-ZB4-000	CLIP, WIRE.	1	-	-----	EDS1, EDT1		
					-	1	-----	1018479	EDS1, EDT1	
	10	L	32343-892-003	KNOB, COCK LEVER.	1	-	-----	EDT1		
					-	1	-----	1018479	EDT1	
	13	L	36106-892-003	BUSH, CONTROL KNOB.	1	-	-----	EDT1		
					-	1	-----	1018479	EDT1	
	14	L	36110-ZB4-702	SWITCH ASSY., ENGINE KILL.	1	-	-----	EDT1		
					-	1	-----	1018479	EDT1	
	18	L	50319-ZB2-000	RUBBER, TANK MOUNTING.	2	-	-----	EDS1, EDT1, ES2, VMQ3, VMT3, VSB4		
					-	2	-----	-----	ES2	

NOTE A:PART NO. CHANGE D:NEWLY PROVIDED E:PART NO. DELETION K:REQUIRED NO. CORRECTION L:APPLICATION SERIAL NO. CORRECTION
M:PART DESCRIPTION CORRECTION T:APPLICATION CORRECTION Z:REMARKS CHANGE

PARTS CATALOGUE NEWS

BOOKNo. : 13Z7E803

Block No.	Ref. No.	Note	Part No.	Description	Reqd. QTY		Serial No.	Parts catalogue code
					GX 390 H1	GX 390 H2		
					-	2	----- 1018479	EDS1, EDT1
	19	L	89216-ZB4-000	WRENCH, PLUG.	1	-	-----	EDS1, EDT1, ES2, ES3S, ES4S, VMQ3, VMT3, VS4, VS6
					-	1	-----	ES2
					-	1	----- 1018479	EDS1, EDT1
	20	L	90101-692-000	SCREW, GLOVE BOX.	1	-	-----	EDS1, EDT1
					-	1	----- 1018479	EDS1, EDT1
E-40-1	1	L	18310-ZD1-E32	MUFFLER COMP. (SANKEI).....	1	-	-----	EDS1, EDT1, ES3S, ES4S
					-	1	----- 1018479	EDS1, EDT1
	2	L	18320-ZG2-000	PROTECTOR, MUFFLER OUTER.	1	-	-----	EDS1, EDT1, ES2, ES3S, ES4S, VMQ3, VMT3, VS4, VS6, VSB4
					-	1	-----	ES2
					-	1	----- 1018479	EDS1, EDT1
	3	L	18325-ZB4-000	PROTECTOR, MUFFLER INNER.	1	-	-----	EDS1, EDT1, ES2, ES3S, ES4S, VMQ3, VMT3, VS4, VS6, VSB4
					-	1	-----	ES2
					-	1	----- 1018479	EDS1, EDT1
	4	L	18329-ZB4-000	SEAL, MUFFLER PROTECTOR.	2	-	-----	EDS1, EDT1, ES2, ES3S, ES4S, VMQ3, VMT3, VS4, VS6, VSB4
					-	2	-----	ES2
					-	2	----- 1018479	EDS1, EDT1
	6	L	18355-ZB4-630	ARRESTER, SPARK.	1	-	-----	EDS1, EDT1
					-	1	----- 1018479	EDS1, EDT1
	7	L	90002-ZE2-U91	SCREW, TAPPING, 4X8.	1	-	-----	EDS1, EDT1
					-	1	----- 1018479	EDS1, EDT1
	8	L	95701-06010-00	BOLT, FLANGE, 6X10.	1	-	-----	EDS1, EDT1, VMQ3, VMT3
					-	1	----- 1018479	EDS1, EDT1
	9	L	95701-06012-00	BOLT, FLANGE, 6X12.	7	-	-----	EDS1, EDT1

NOTE A:PART NO. CHANGE D:NEWLY PROVIDED E:PART NO. DELETION K:REQUIRED NO. CORRECTION L:APPLICATION SERIAL NO. CORRECTION
M:PART DESCRIPTION CORRECTION T:APPLICATION CORRECTION Z:REMARKS CHANGE

PARTS CATALOGUE NEWS

BOOKNo. : 13Z7E803

Block No.	Ref. No.	Note	Part No.	Description	Reqd. QTY		Serial No.	Parts catalogue code
					GX 390 H1	GX 390 H2		
					-	7	----- 1018479	EDS1, EDT1

E-40-4 MARK

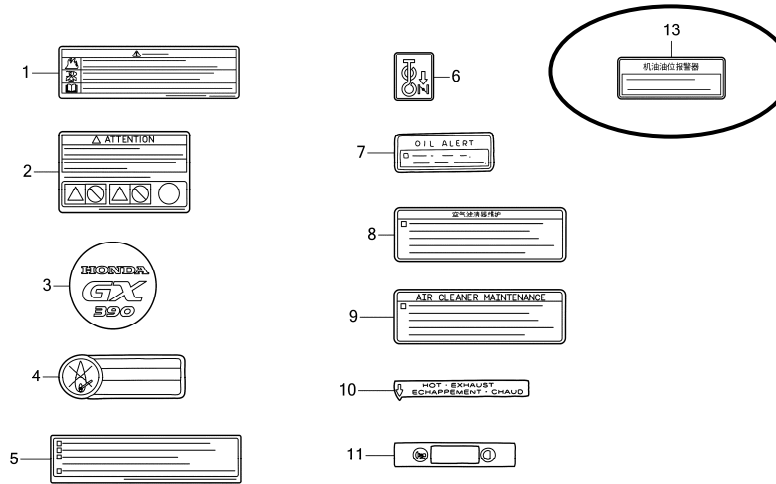

Z7E0E4004A

E-40-4	9	T	87533-ZC0-630	MARK, AIR CLEANER (ENGLISH)	1	1	-----	-----	EDF6, EDS2, ES2, ES3S, ES4S, VMQ3, VMT3, VPKK, VPXX, VS4, VS6, VSB4 VXEK, VXKS
					(1)	(1)	-----	-----	VPKK, VPX4, VPXB, VPXE, VPXJ, VPXK, VPXX, VXEK, VXKS
					1	-	-----	0010334	EDS1, EDT1
					-	1	1062906	-----	EDS1, EDT1
	13	D	87532-Z7E-010	MARK, OIL ALERT (CHINESE)	-	1	1062906	-----	EDS1, EDT1

NOTE A:PART NO. CHANGE D:NEWLY PROVIDED E:PART NO. DELETION K:REQUIRED NO. CORRECTION L:APPLICATION SERIAL NO. CORRECTION
M:PART DESCRIPTION CORRECTION T:APPLICATION CORRECTION Z:REMARKS CHANGE

HONDA PARTS CATALOGUE NEWS

PARTS CATALOGUE - CORRECTED

CODE NO.	13Z7E803
PARTS CATALOGUE NEWS	GX390H1 GX390H2
NEWS NO.	012

Block No.	Ref. No.	Note	Part No.	Description	Reqd. QTY		Serial No.	Parts catalogue code
					GX 390 H1	GX 390 H2		
E-17	4	D	17620-Z1T-801	CAP COMP., FUEL FILLER (CHROME PLATED) (TOYOSHA)	(1)	-	-----	QEBR, QHBR, QXBR
	5	D	17631-Z1T-810	PACKING, FUEL FILLER CAP.....	(1)	-	-----	QEBR, QHBR, QXBR

NOTE A:PART NO. CHANGE D:NEWLY PROVIDED E:PART NO. DELETION K:REQUIRED NO. CORRECTION L:APPLICATION SERIAL NO. CORRECTION
M:PART DESCRIPTION CORRECTION T:APPLICATION CORRECTION Z:REMARKS CHANGE

HONDA PARTS CATALOGUE NEWS

PARTS CATALOGUE - CORRECTED

CODE NO.	13Z7E803
PARTS CATALOGUE NEWS	GX390H1 GX390H2
NEWS NO.	013

Block No.	Ref. No.	Note	Part No.	Description	Reqd. QTY		Serial No.	Parts catalogue code	
					GX 390 H1	GX 390 H2			
E-14-1	16	T	16260-ZE3-D22	STAY ASSY., MANUAL CHOKE.....	1	-	----- 0002756	EDT1	
			16260-Z7E-000	1	-	0002757 -----	EDT1	
						1	-	-----	EDF6, EDS2, VPKK, VPX4, VPXB, VPXE, VPXJ, VPXK, VPXX, VXEK, VXKS
						-	1	-----	EDS1, EDS2, EDT1, ES2, VPKK, VPXB, VPXE, VPXK, VPXX, VXEK, VXKS
		19	T	16263-ZA0-000	JOINT, ROD.....	1	-	----- 0002756	EDS1, EDT1
	16263-Z7B-000			1	-	0002757 -----	EDS1, EDT1	
						1	-	-----	EDF6, EDS2, ES2, ES3S, ES4S, VMQ3, VMT3, VPKK, VPX4, VPXB, VPXE, VPXJ, VPXK, VPXX, VS4, VS6, VSB4, VXEK, VXKS
						-	1	-----	EDS1, EDS2, EDT1, ES2, VPKK, VPXB, VPXE, VPXK, VPXX, VXEK, VXKS
		21	T	16265-ZE2-721	STOPPER, CHOKE ROD.....	1	-	----- 0002756	EDS1, EDT1
	16265-Z7E-000			1	-	0002757 -----	EDS1, EDT1	
					1	-	-----	EDF6, EDS2, ES2, ES3S, ES4S, VMQ3, VMT3, VPKK, VPX4, VPXB, VPXE, VPXJ, VPXK, VPXX, VS4, VS6, VSB4, VXEK, VXKS	
					-	1	-----	EDS1, EDS2, EDT1, ES2, VPKK, VPXB, VPXE, VPXK, VPXX, VXEK, VXKS	
	37	T	94540-02010	E-RING, 2MM.....	1	-	----- 0000669	EDS1, EDT1	
90601-Z7E-000			1	-	0000670 -----	EDS1, EDT1		

NOTE A:PART NO. CHANGE D:NEWLY PROVIDED E:PART NO. DELETION K:REQUIRED NO. CORRECTION L:APPLICATION SERIAL NO. CORRECTION
M:PART DESCRIPTION CORRECTION T:APPLICATION CORRECTION Z:REMARKS CHANGE

PARTS CATALOGUE NEWS

BOOKNo. : 13Z7E803

Block No.	Ref. No.	Note	Part No.	Description	Reqd. QTY		Serial No.	Parts catalogue code
					GX 390 H1	GX 390 H2		
					1	-	-----	EDF6, EDS2, ES2, ES3S, ES4S, VMQ3, VMT3, VPKK, VPX4, VPXB, VPXE, VPXJ, VPXK, VPXX, VS4, VS6, VSB4, VXEK, VXKS
					-	1	-----	EDS1, EDS2, EDT1, ES2, VPKK, VPXB, VPXE, VPXK, VPXX, VXEK, VXKS
	38	T	94540-04010	E-RING, 4MM.....	1	-	----- 0000669	EDS1, EDT1
		T	90602-Z7E-000	1	-	0000670 -----	EDS1, EDT1
					1	-	-----	EDF6, EDS2, ES2, ES3S, ES4S, VMQ3, VMT3, VPKK, VPX4, VPXB, VPXE, VPXJ, VPXK, VPXX, VS4, VS6, VSB4, VXEK, VXKS
					-	1	-----	EDS1, EDS2, EDT1, ES2, VPKK, VPXB, VPXE, VPXK, VPXX, VXEK, VXKS
	39	T	94540-07010	E-RING, 7MM.....	1	-	----- 0000669	EDS1, EDT1
		T	90603-Z7E-000	1	-	0000670 -----	EDS1, EDT1
					1	-	-----	EDF6, EDS2, ES2, ES3S, ES4S, VMQ3, VMT3, VPKK, VPX4, VPXB, VPXE, VPXJ, VPXK, VPXX, VS4, VS6, VSB4, VXEK, VXKS
					-	1	-----	EDS1, EDS2, EDT1, ES2, VPKK, VPXB, VPXE, VPXK, VPXX, VXEK, VXKS
E-20	17	T	32110-Z5K-800	HARNESS ASSY., ENGINE WIRE....	-	1	-----	LH, LH1, QH, QH1, QHG, QMH, QN, SH, SH1, SM11

NOTE A:PART NO. CHANGE D:NEWLY PROVIDED E:PART NO. DELETION K:REQUIRED NO. CORRECTION L:APPLICATION SERIAL NO. CORRECTION
M:PART DESCRIPTION CORRECTION T:APPLICATION CORRECTION Z:REMARKS CHANGE

HONDA PARTS CATALOGUE NEWS

PARTS CATALOGUE - CORRECTED

CODE NO.	13Z7E803
PARTS CATALOGUE NEWS	GX390H1 GX390H2
NEWS NO.	014

Block No.	Ref. No.	Note	Part No.	Description	Reqd. QTY		Serial No.		Parts catalogue code
					GX 390 H1	GX 390 H2			
E-2	2	T	12204-ZE2-306	GUIDE, IN. VALVE (O. S.).....	1	-	-----	-----	EDF6, EDS1, EDS2, EDT1, ES3S, ES4S, LH, QA2, QH, QHE, QXHQ, SH, SHE SM11, SX, SXC, SXE, VPKK, VPX4, VPXB, VPXE, VPXJ, VPKX, VPXX, VSP, VX VXEK, VXKS
					-	1	-----	-----	EDS2, ES2, LH1, PX, QH1, QMH, QN, QX, QXE, SH1, SWX2, SX1, SXC1, VPKK VPXX, VTE5, VX1, VX1M, VXE, VXEK, VXEM, VXKS
	3	T	12205-ZE2-305	GUIDE, EX. VALVE (O. S.).....	1	-	-----	-----	EDF6, EDS1, EDS2, EDT1, ES3S, ES4S, LH, QA2, QH, QHE, QXHQ, SH, SHE SM11, SX, SXC, SXE, VPKK, VPX4, VPXB, VPXE, VPXJ, VPKX, VPXX, VSP, VX VXEK, VXKS
					-	1	-----	-----	EDS2, ES2, LH1, PX, QH1, QMH, QN, QX, QXE, SH1, SWX2, SX1, SXC1, VPKK VPXX, VTE5, VX1, VX1M, VXE, VXEK, VXEM, VXKS
E-3	4	D	35480-Z5T-003	SWITCH ASSY., OIL LEVEL.....	(1)	-	-----	-----	QEBR, QXBR
E-8	1	T	13011-Z7E-931	RING SET, PISTON (0.25) (TPR)...	-	(1)	-----	-----	EDS2, ES2, LH1, PX, QH1, QMH, QN, QX, QXE, SH1, SWX2, SX1, SXC1, VPKK VPXX, VTE5, VX1, VX1M, VXE, VXEK, VXEM, VXKS
			13012-Z7E-931	RING SET, PISTON (0.50) (TPR)...	-	(1)	-----	-----	EDS2, ES2, LH1, PX, QH1, QMH, QN, QX, QXE, SH1, SWX2, SX1, SXC1, VPKK VPXX, VTE5, VX1, VX1M, VXE, VXEK, VXEM, VXKS
			13013-Z7E-931	RING SET, PISTON (0.75) (TPR)...	-	(1)	-----	-----	EDS2, ES2, LH1, PX, QH1, QMH, QN, QX, QXE, SH1, SWX2, SX1, SXC1, VPKK VPXX, VTE5, VX1, VX1M, VXE, VXEK, VXEM, VXKS
	2	T	13102-Z7E-930	PISTON (0.25).....	-	(1)	-----	-----	EDS2, ES2, LH1, PX, QH1, QMH, QN, QX, QXE, SH1, SWX2, SX1, SXC1, VPKK VPXX, VTE5, VX1, VX1M, VXE, VXEK, VXEM, VXKS
			13103-Z7E-930	PISTON (0.50).....	-	(1)	-----	-----	EDS2, ES2, LH1, PX, QH1, QMH, QN, QX, QXE, SH1, SWX2, SX1, SXC1, VPKK VPXX, VTE5, VX1, VX1M, VXE, VXEK, VXEM, VXKS

NOTE A:PART NO. CHANGE D:NEWLY PROVIDED E:PART NO. DELETION K:REQUIRED NO. CORRECTION L:APPLICATION SERIAL NO. CORRECTION
M:PART DESCRIPTION CORRECTION T:APPLICATION CORRECTION Z:REMARKS CHANGE

PARTS CATALOGUE NEWS

BOOKNo. :13Z7E803

Block No.	Ref. No.	Note	Part No.	Description	Reqd. QTY		Serial No.	Parts catalogue code
					GX 390 H1	GX 390 H2		
		T	13104-Z7E-930	PISTON (0.75).....	-	(1)	-----	EDS2, ES2, LH1, PX, QH1, QMH, QN, QX, QXE, SH1, SWX2, SX1, SXC1, VPKK VPXX, VTE5, VX1, VX1M, VXE, VXEK, VXEM, VXKS
	4	T	13200-Z1C-305	ROD ASSY., CONNECTING (0.25 UNDER SIZE)	(1)	-	-----	EDF6, EDS1, EDS2, EDT1, VSP
					-	(1)	-----	EDS2, ES2, LH1, PX, QH1, QMH, QN, QX, QXE, SH1, SWX2, SX1, SXC1, VPKK VPXX, VTE5, VX1, VX1M, VXE, VXEK, VXEM, VXKS

NOTE A:PART NO. CHANGE D:NEWLY PROVIDED E:PART NO. DELETION K:REQUIRED NO. CORRECTION L:APPLICATION SERIAL NO. CORRECTION
M:PART DESCRIPTION CORRECTION T:APPLICATION CORRECTION Z:REMARKS CHANGE

HONDA PARTS CATALOGUE NEWS

PARTS CATALOGUE - CORRECTED

CODE NO.	13Z7E803
PARTS CATALOGUE NEWS	GX390H1 GX390H2
NEWS NO.	015

Block No.	Ref. No.	Note	Part No.	Description	Reqd. QTY		Serial No.	Parts catalogue code	
					GX 390 H1	GX 390 H2			
E-14-1	44	L	99204-ZA0-0450	JET SET, PILOT, #45.....	1	-	-----	EDS1, EDS2, EDT1, ES2, ES3S, ES4S, VMQ3, VMT3, VPXJ, VS4, VS6, VSB4 VXEK, VXKS	
					1	-	-----	1001462	VPKK, VPX4, VPXB, VPXE, VPXK, VPXX
					1	-	-----	1055753	EDF6
					1	-	-----	1001463	VPKK, VPX4, VPXB, VPXE, VPXK, VPXX
					1	-	-----	1055754	EDF6
		T	99204-ZE0-0450	1	-	-----	EDS1, EDS2, EDT1, ES2, VPKK, VPXB, VPXE, VPXK, VPXX, VXEK, VXKS	
E-17	4	L	17620-Z1T-800	CAP COMP., FUEL FILLER (CHROME PLATED) (TOYOSHA)	1	-	-----	LH, LH1, LH2, LHB5, LHP1, LXE9, PX, QA2, QBE1, QH, QH1, QHB1, QHB3 QHB5, QHE, QHP1, QMH, QN, QP, QX, QXE, QXEK, QXHQ, QXK, SH, SH1, SHE SM11, SWE2, SWX2, SX, SX1, SXC, SXC1, SXE, SXE1, VSP, VX, VX1, VXE VXX, VXU1	
					1	-	-----	1050926	QEBR, QHBR, QXBR
					-	1	-----	1138753	LH, LH1, PX, QH, QH1, QHE, QMH, QN, QX, QXE, QXHQ, SH, SH1, SHE, SM11 SWX2, SX, SX1, SXC, SXC1, VX, VX1, VXE
					1	-	-----	1050927	QEBR, QHBR, QXBR
					(1)	-	-----	-----	QEBR, QHBR, QXBR
		T	17620-Z1T-801	-	1	-----	LH, LH1, PX, QH, QH1, QHE, QMH, QN, QX, QXE, QXHQ, SH, SH1, SHE, SM11 SWX2, SX, SX1, SXC, SXC1, VX, VX1, VXE	

NOTE A:PART NO. CHANGE D:NEWLY PROVIDED E:PART NO. DELETION K:REQUIRED NO. CORRECTION L:APPLICATION SERIAL NO. CORRECTION
M:PART DESCRIPTION CORRECTION T:APPLICATION CORRECTION Z:REMARKS CHANGE

PARTS CATALOGUE NEWS

BOOKNo. :13Z7E803

Block No.	Ref. No.	Note	Part No.	Description	Reqd. QTY		Serial No.	Parts catalogue code
					GX 390 H1	GX 390 H2		
	5	L	17631-Z1T-800	PACKING, FUEL FILLER CAP (39X62X3) (TOYOSHA)	1	-	-----	LH, LH1, LH2, LHB5, LHP1, LXE9, PX, QA2, QBE1, QH, QH1, QHB1, QHB3, QHB5, QHE, QHP1, QMH, QN, QP, QX, QXE, QXEK, QXHQ, QXK, SH, SH1, SHE, SM11, SWE2, SWX2, SX, SX1, SXC, SXC1, SXE, SXE1, VSP, VX, VX1, VXE, VXK, VXU1
					1	-	-----	1050926 QEBR, QHBR, QXBR
					-	1	-----	1138753 LH, LH1, PX, QH, QH1, QHE, QMH, QN, QX, QXE, QXHQ, SH, SH1, SHE, SM11, SWX2, SX, SX1, SXC, SXC1, VX, VX1, VXE
		T	17631-Z1T-810	PACKING, FUEL FILLER CAP.....	1	-	1050927	----- QEBR, QHBR, QXBR
					(1)	-	-----	QEBR, QHBR, QXBR
					-	1	1138754	----- LH, LH1, PX, QH, QH1, QHE, QMH, QN, QX, QXE, QXHQ, SH, SH1, SHE, SM11, SWX2, SX, SX1, SXC, SXC1, VX, VX1, VXE
	16		91424-Z4K-803	TUBE, FUEL, 4.5X180(FKM).....	-	1	-----	1253503 VPKK, VPXB, VPXE, VPXK, VPXX
		A	91424-Z4K-804	-	1	1253504	----- VPKK, VPXB, VPXE, VPXK, VPXX

NOTE A:PART NO. CHANGE D:NEWLY PROVIDED E:PART NO. DELETION K:REQUIRED NO. CORRECTION L:APPLICATION SERIAL NO. CORRECTION
M:PART DESCRIPTION CORRECTION T:APPLICATION CORRECTION Z:REMARKS CHANGE

HONDA PARTS CATALOGUE NEWS

PARTS CATALOGUE - CORRECTED

CODE NO.	13Z7E803
PARTS CATALOGUE NEWS	GX390H1 GX390H2
NEWS NO.	016

Block No.	Ref. No.	Note	Part No.	Description	Reqd. QTY		Serial No.	Parts catalogue code						
					GX 390 H1	GX 390 H2								
E-6	1	L	11300-ZE3-604	COVER ASSY., CRANKCASE.....	1	-	----- 0010334	VPX4						
					1	-	0001149 0010334	VSP						
					1	-	0010335	-----	VPX4, VSP					
										1	1	-----	-----	PX, QA2, QBE1, QEBR, QH, QH1, QHB1, QHB3, QHB5, QHBR, QHE, QHP1, QMH QN, QP, QX, QXBR, QXE, QXEK, QXHQ, QXK, VMQ3, VPKK, VPXB, VPXE, VPXJ VPXK, VPXX, VSB4, VTE5, VX, VX1, VX1M, VXE, VXEK, VXEM, VVK, VXKS, VXU1
					1	-	-----	-----	SH, SH1, SHE, SM11, SWE2, SWX2, SX, SX1, SXC, SXC1, SXE, SXE1					
										1	-	0000027	-----	EDS1, EDT1
										1	-	-----	1207292	EDS1, EDT1, SH, SH1, SHE, SM11, SWX2, SX, SX1, SXC, SXC1
					1	-	-----	-----	EDS1, EDT1, SH, SH1, SHE, SM11, SWX2, SX, SX1, SXC, SXC1					
										1	-	-----	-----	EDF6, EDS2, VS4, VS6
					-	1	-----	-----	EDS2					
										1210329	-----	EDS2		
					1	-	-----	-----	ES3S, ES4S					
										1210330	-----	EDS2		
7	L	16510-ZE3-000	GOVERNOR ASSY.....	1	-	-----	-----	ES3S, ES4S						
				1	-	-----	0001591	EDS1, EDT1						
				1	-	-----	0010334	VPX4, VSP						

NOTE A:PART NO. CHANGE D:NEWLY PROVIDED E:PART NO. DELETION K:REQUIRED NO. CORRECTION L:APPLICATION SERIAL NO. CORRECTION
M:PART DESCRIPTION CORRECTION T:APPLICATION CORRECTION Z:REMARKS CHANGE

PARTS CATALOGUE NEWS

BOOKNo. :13Z7E803

Block No.	Ref. No.	Note	Part No.	Description	Reqd. QTY		Serial No.	Parts catalogue code
					GX 390 H1	GX 390 H2		
		T	16510-Z7E-000	1	-	-----	EDF6, EDS2, PX, QA2, QBE1, QEBR, QH, QH1, QHB1, QHB3, QHB5, QHBR, QHE QHP1, QMH, QN, QP, QX, QXBR, QXE, QXEK, QXHQ, QXK, SH, SH1, SHE, SM11 SWE2, SWX2, SX, SX1, SXC, SXC1, SXE, SXE1, VMQ3, VPKK, VPXB, VPXE VPXJ, VPXK, VPXX, VS4, VS6, VSB4, VTE5, VX, VX1, VX1M, VXE, VXEK, VXEM VXK, VXKS, VXU1
					1	-	0001592	EDS1, EDT1
					1	-	0010335	VPX4, VSP
					-	1	-----	EDS1, EDS2, EDT1, PX, QH, QH1, QHE, QHEG, QHG, QMH, QN, QX, QXE, QXHQ SH, SH1, SHE, SM11, SWX2, SX, SX1, SXC, SXC1, VPKK, VPXB, VPXE, VPXK VPXX, VTE5, VX, VX1, VX1M, VXE, VXEK, VXEM, VXKS
9	L		16512-ZE3-000	HOLDER, GOVERNOR WEIGHT.....	1	-	-----	ES3S, ES4S
					1	-	0001591	EDS1, EDT1
					1	-	0010334	VPX4, VSP
		T	16512-Z7E-000	1	-	-----	EDF6, EDS2, PX, QA2, QBE1, QEBR, QH, QH1, QHB1, QHB3, QHB5, QHBR, QHE QHP1, QMH, QN, QP, QX, QXBR, QXE, QXEK, QXHQ, QXK, SH, SH1, SHE, SM11 SWE2, SWX2, SX, SX1, SXC, SXC1, SXE, SXE1, VMQ3, VPKK, VPXB, VPXE VPXJ, VPXK, VPXX, VS4, VS6, VSB4, VTE5, VX, VX1, VX1M, VXE, VXEK, VXEM VXK, VXKS, VXU1
					1	-	0001592	EDS1, EDT1
					1	-	0010335	VPX4, VSP
					-	1	-----	EDS1, EDS2, EDT1, PX, QH, QH1, QHE, QHEG, QHG, QMH, QN, QX, QXE, QXHQ SH, SH1, SHE, SM11, SWX2, SX, SX1, SXC, SXC1, VPKK, VPXB, VPXE, VPXK VPXX, VTE5, VX, VX1, VX1M, VXE, VXEK, VXEM, VXKS
14	L		91201-ZE3-004	OIL SEAL, 35X52X8 (ARAI).....	1	-	-----	ES3S, ES4S
					1	-	0001591	EDS1, EDT1
					1	-	0010334	VPX4
					1	-	0001149	0010334 VSP
		T	91201-Z7E-003	OIL SEAL, 35X52X8.....	1	-	-----	EDF6, EDS2, PX, QA2, QBE1, QEBR, QH, QH1, QHB1, QHB3, QHB5, QHBR, QHE QHP1, QMH, QN, QP, QX, QXBR, QXE, QXEK, QXHQ, QXK, SH, SH1, SHE, SM11 SWE2, SWX2, SX, SX1, SXC, SXC1, SXE, SXE1, VMQ3, VPKK, VPXB, VPXE VPXJ, VPXK, VPXX, VS4, VS6, VSB4, VTE5, VX, VX1, VX1M, VXE, VXEK, VXEM VXK, VXKS, VXU1

NOTE A:PART NO. CHANGE D:NEWLY PROVIDED E:PART NO. DELETION K:REQUIRED NO. CORRECTION L:APPLICATION SERIAL NO. CORRECTION
M:PART DESCRIPTION CORRECTION T:APPLICATION CORRECTION Z:REMARKS CHANGE

PARTS CATALOGUE NEWS

BOOKNo. :13Z7E803

Block No.	Ref. No.	Note	Part No.	Description	Reqd. QTY		Serial No.	Parts catalogue code
					GX 390 H1	GX 390 H2		
					1	-	0001592 -----	EDS1, EDT1
					1	-	0010335 -----	VPX4, VSP
					-	1	-----	EDS1, EDS2, EDT1, PX, QH, QH1, QHE, QHEG, QHG, QMH, QN, QX, QXE, QXHQ, SH, SH1, SHE, SM11, SWX2, SX, SX1, SXC, SXC1, VPKK, VPXB, VPXE, VPXK, VPXX, VTE5, VX, VX1, VX1M, VXE, VXEK, VXEM, VXKS
E-7	3	L	13310-ZF6-W42	CRANKSHAFT COMP.....	1	-	----- 0010334	VPX4, VSP
		T	13310-Z7E-810	1	-	0010335 -----	VPX4, VSP
					1	1	-----	ES3S, ES4S, VMQ3, VPKK, VPXB, VPXE, VPXJ, VPXK, VPXX, VS4, VS6, VSB4, VTE5, VX, VX1, VX1M, VXE, VXEK, VXEM, VXK, VXKS, VXU1

NOTE A:PART NO. CHANGE D:NEWLY PROVIDED E:PART NO.DELETION K:REQUIRED NO. CORRECTION L:APPLICATION SERIAL NO. CORRECTION
M:PART DESCRIPTION CORRECTION T:APPLICATION CORRECTION Z:REMARKS CHANGE

HONDA PARTS CATALOGUE NEWS

PARTS CATALOGUE - CORRECTED

CODE NO.	13Z7E803
PARTS CATALOGUE NEWS	GX390H1 GX390H2
NEWS NO.	017

Block No.	Ref. No.	Note	Part No.	Description	Reqd. QTY		Serial No.	Parts catalogue code
					GX 390 H1	GX 390 H2		
E-12	8	T	32197-Z1T-000	SUB HARNESS.....	1	-	-----	EDF6
					-	1	-----	EDS1, EDS2, EDT1
		T	32197-ZH8-003	1	-	-----	EDS1, EDS2, EDT1

NOTE A:PART NO. CHANGE D:NEWLY PROVIDED E:PART NO. DELETION K:REQUIRED NO. CORRECTION L:APPLICATION SERIAL NO. CORRECTION
M:PART DESCRIPTION CORRECTION T:APPLICATION CORRECTION Z:REMARKS CHANGE

HONDA PARTS CATALOGUE NEWS

PARTS CATALOGUE - CORRECTED

CODE NO.	13Z7E803
PARTS CATALOGUE NEWS	GX390H1 GX390H2
NEWS NO.	018

Block No.	Ref. No.	Note	Part No.	Description	Reqd. QTY		Serial No.	Parts catalogue code
					GX 390 H1	GX 390 H2		
E-3	15	T	91004-KZR-602	BEARING, RADIAL BALL, 6202 (FUJIKOSHI)	-	1	-----	QHEG, QHG
					-	1	1146217	EDS1, EDS2, QXE, VPKK, VPXE, VPXK, VPXX, VTE5, VXE, VXEK, VXEM
					-	1	1146804	LH, LH1, QH, QH1, QMH, QN, SH, SH1, SM11
					-	1	1147525	QHE, SHE
					-	1	1149940	EDT1, ES2, PX, QX, QXHQ, SWX2, SX, SX1, SXC, SXC1, VPXB, VX, VX1, VX1M, VXKS
E-40	1	L	16173-001-004	O-RING.....	1	-	-----	EDS1, EDT1, ES2, ES3S, ES4S, VMQ3, VMT3, VS4, VS6, VSB4
					-	1	-----	ES2
					-	1	1018479	EDS1, EDT1
	2	L	16950-ZB4-015	COCK ASSY., FUEL.....	1	-	-----	EDS1, EDT1, ES2, ES3S, ES4S, VMQ3, VMT3, VS4, VS6, VSB4
					-	1	-----	ES2
					-	1	1018479	EDS1, EDT1
	3	L	16952-ZB4-005	SCREEN SET, FUEL STRAINER.....	1	-	-----	EDS1, EDT1, ES2, ES3S, ES4S, VMQ3, VMT3, VS4, VS6, VSB4
					-	1	-----	ES2
					-	1	1018479	EDS1, EDT1

NOTE A:PART NO. CHANGE D:NEWLY PROVIDED E:PART NO. DELETION K:REQUIRED NO. CORRECTION L:APPLICATION SERIAL NO. CORRECTION
M:PART DESCRIPTION CORRECTION T:APPLICATION CORRECTION Z:REMARKS CHANGE

PARTS CATALOGUE NEWS

BOOKNo. :13Z7E803

Block No.	Ref. No.	Note	Part No.	Description	Reqd. QTY		Serial No.		Parts catalogue code
					GX 390 H1	GX 390 H2			
	4	L	16958-397-771	O-RING, 9.0X1.3.....	1	-	-----	-----	EDS1, EDT1, ES2, ES3S, ES4S, VMQ3, VMT3, VS4, VS6, VSB4
					-	1	-----	-----	ES2
					-	1	-----	1018479	EDS1, EDT1
	5	L	16959-471-831	FILTER, CUP.....	1	-	-----	-----	EDS1, EDT1, ES2, ES3S, ES4S, VMQ3, VMT3, VS4, VS6, VSB4
					-	1	-----	-----	ES2
					-	1	-----	1018479	EDS1, EDT1
	6	L	16967-GA6-671	CUP, FUEL STRAINER.....	1	-	-----	-----	EDS1, EDT1, ES2, ES3S, ES4S, VMQ3, VMT3, VS4, VS6, VSB4
					-	1	-----	-----	ES2
					-	1	-----	1018479	EDS1, EDT1
	33		17620-899-800	CAP COMP., FUEL FILLER.....	1	-	-----	-----	ES2, VMQ3, VMT3, VS4, VS6, VSB4
					-	1	-----	1201051	ES2
		A	17620-899-801	-	1	1201052	-----	ES2
	34		17631-899-000	PACKING, FUEL FILLER CAP.....	1	-	-----	-----	ES2, ES3S, ES4S, VMQ3, VMT3, VS4, VS6, VSB4
					-	1	-----	1201051	ES2
		A	17631-899-010	-	1	1201052	-----	ES2

NOTE A:PART NO. CHANGE D:NEWLY PROVIDED E:PART NO. DELETION K:REQUIRED NO. CORRECTION L:APPLICATION SERIAL NO. CORRECTION
M:PART DESCRIPTION CORRECTION T:APPLICATION CORRECTION Z:REMARKS CHANGE

HONDA PARTS CATALOGUE NEWS

PARTS CATALOGUE - CORRECTED

CODE NO.	13Z7E803
PARTS CATALOGUE NEWS	GX390H1 GX390H2
NEWS NO.	019

Block No.	Ref. No.	Note	Part No.	Description	Reqd. QTY		Serial No.	Parts catalogue code
					GX 390 H1	GX 390 H2		
E-29	1	T	99004-21002	WRENCH, BOX (P21).....	1	-	-----	EDF6
					-	1	-----	EDS1, EDT1

NOTE A:PART NO. CHANGE D:NEWLY PROVIDED E:PART NO. DELETION K:REQUIRED NO. CORRECTION L:APPLICATION SERIAL NO. CORRECTION
M:PART DESCRIPTION CORRECTION T:APPLICATION CORRECTION Z:REMARKS CHANGE